

*Stoneware importation, 1565–1603*

After 1565 it becomes possible to follow the levels of coastal imports of stonewares both in the Coastal Port Books of the Exchequer and in the Town Customs Accounts. It is clear from these documents that throughout the reign of Elizabeth most stonewares arriving in Exeter came from London. At this period they must have been Rhenish and not London products (Hurst 1964b, 142). They came with a range of goods such as pitch and tar, madder, hops and bell-metal, which seem largely to have been re-exports from the Low Countries.

Stonewares were normally sent in maunds, and most coastal entries simply record the number of maunds imported without giving the number of pots in each. However in 42 instances the number of vessels per maund is also given, the city accounts providing most examples. These show that maunds could contain as few as 50 or as many as 500 pots; many contained 100 or 150 pots. In these instances there were on average 105 pots in each maund. Since individual maunds varied widely in capacity, it is not possible to follow the yearly fluctuations of coastal imports, but the sample is sufficiently large to show the average size of a maund, and so by counting the number of maunds per year to estimate the average number of pots imported per year.

There survive from the reign of Elizabeth 25 half-yearly Coastal Port Books, covering twelve and a half years. Amongst 353 recorded shipments of pottery from other English ports, 312 are specifically described as stone pots; almost 90% of the recorded Elizabethan coastal imports of pottery at Exeter were therefore of Rhenish stoneware. The Coastal Port Books also list 33 shipments of cups, some of which were clearly stonewares since they had covers.<sup>2</sup> At the risk of minor distortion of the figures, all these have been included in the estimate of stoneware imports.

In the years for which Coastal Port Books of the Exchequer survive, a total of 386 shipments of pottery is recorded, of which about 90% are of maunds; the few others came in large containers, again of variable size but of comparable capacities. On average, rather more than 30 cargoes per year were recorded. Given an average of 100 vessels per maund, a total of *c.* 3100 pots was imported by coast in each year of Elizabeth's reign. This figure is probably an under-estimate; one suspects that low totals in the books of some years, such as 1565 and 1570, result not from a near-absence of shipments but from lack of detail in the records. The local customs accounts contain references to considerably higher shipments during years for which the Coastal Port Books have perished. In 1592–3, a total of 63½ maunds of stone pots were imported into Exeter from London in nine different shipments, and in the same year Nicholas Martin also imported two 'tuns' of stone pots from London. In 1589–90 a total of 56 maunds, comprising 38 of stone pots and 18 of pots, came from London. In these two years the total level of stoneware importation must have been of well over 5000 vessels. Entries in other years in the city accounts are lower but are clearly defective, as comparison with the parallel accounts in the Exchequer series demonstrates.

The quantities brought directly from the Low Countries were smaller. The Foreign Port Books of only four and a half years survive from the reign of Elizabeth. The arrival of an average of 320 pots per year is recorded in these books. The city accounts, incomplete as they are, show higher levels of direct importation in other years: in 1579–80 1100 stone pots were imported with Low Countries cargoes, and in 1580–81 another 1050 were recorded.<sup>3</sup> There is hardly enough information to suggest the average annual level of foreign imports, but it may perhaps have been between 400 and 700 pots.

As a minimum then, on average about 3500 stoneware vessels were brought into Exeter during each year of the late 16th century. The total must have been considerably greater in some years, and in view of the deficiencies of the documentary evidence, a figure of 4–5000 pots per year can hardly be an under-estimate.

The origins of stoneware shipments were surprisingly varied (Fig. 57). London dominated the trade, with about 75% of the total per year. Cargoes from Dartmouth were quite numerous, forming about 10% of the total. Like Exeter, Dartmouth seems to have received most of its stoneware from London, and have had little interest in the direct Low Countries trade (e.g. PRO E.190.934/1; 932/17; 927/18). There are also three references to the redistribution of stoneware from Lyme to Exeter, and a single cargo of 500 stone pots was sent from Sandwich in 1571 (PRO E.190.928/2).

The coastal redistribution of stoneware from London can be followed in the London Coastal Port Books for General Wares. This series has been described elsewhere (Allan 1983a, 38–40). It provides evidence of the relative importance of the individual outports as recipients in the coastal stoneware trade. The ports of Devon and Cornwall figured much more prominently in this particular trade than in the other aspects of the London coasting trade: in these years Exeter received only 4% of all cargoes sent from London but up to 22% of the stonewares. The stonewares formed a much larger component of a ship's cargo in the trade from London to the South-West than to eastern England: in the former instance the loads were usually of five, ten or twenty maunds; in the latter they were nearly always of one or two basketfuls. The coastal trade was evidently supplying a specific need for which foreign imports catered only very partially (*ibid.*).

Direct shipments from the Low Countries made up only about 10% of the recorded total of stoneware arriving in Exeter. In 1565, the date of the earliest Foreign Port Book, these came from Antwerp, which had

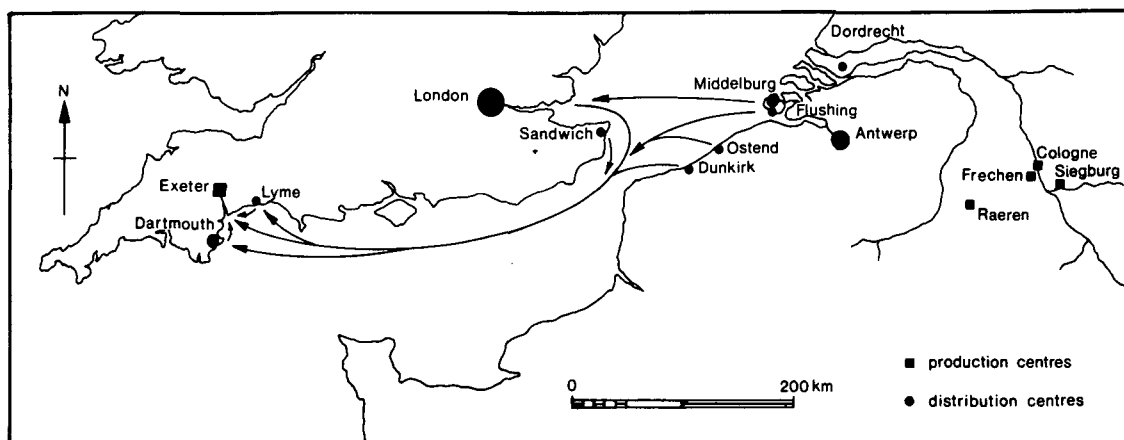

Fig. 57. The distribution of Rhenish stonewares to Exeter, 1565–1620 (source: PRO E.190. Exeter Port Books).

presumably been the main foreign source of stonewares in the early 16th century. Antwerp continued to be the port of shipment in the early 1580s, and in 1581–2, for example, three ships carrying stoneware from there are recorded in the Town Customs Accounts. After its sack in 1585, Antwerp ceased to appear in the Exeter accounts, and its function was assumed by Middelburg, or, rarely, by Flushing. After 1590, however, it seems that direct stoneware imports may almost have ceased. Up to 1589 there is a scatter of references to direct imports in the city accounts. The good series of these documents surviving from the period 1590–1603 records only one further shipment, that of 1592–3. This is surprising, since two, three or more large cargoes were arriving from Middelburg in most of these years, and the majority of these would normally in previous years have carried some stoneware. Many cargoes are described in great detail and during these years the accounts describe some notably high levels of stoneware imports to Exeter from London, of which the total of 63½ maunds in 1592–3 is the largest. This change can perhaps be equated with the granting of a series of monopolies in stoneware importation to merchants trading through London (Henstock 1975, 217–24). The earliest is undated but probably belongs to the years before 1593; the latest was granted in 1601 (*ibid.*). Exeter is not, however, a good place to examine this possibility: if these monopolies were enforced this will be more readily identifiable in the trade of the east-coast ports with their greater direct contact with the Low Countries.

Both the coastal and the foreign stoneware trades were dominated by a few Exeter families; the Martins, Ellacotts and Knights were the most important of these, and the most prominent individuals were Nicholas Martin, Simon Knight and Henry Ellacott. The first two were mayors and the third a member of the Chamber (MacCaffrey 1958, 40, 287–8). Their three families accounted for 64% of all the Elizabethan coastal shipments recorded in the Port Books. Two other families made up another 15% of the total, and men from outside Exeter only 3%. The city accounts of the 1590s show more variety, with a few Londoners and men from Totnes, Exmouth and Tiverton, but the city merchants far outnumber them. Since Exeter merchants were not involved in London's trade with the Low Countries they presumably bought the stonewares when cargoes of Dutch goods were divided in London. Similarly, in the foreign trade the names of William Hurst, the Martins and Simon Knight make up most of the entries. There is no indication that any individual took a particular interest in stoneware imports.

The records provide some evidence regarding the types of stoneware imported. Stone cups are very commonly mentioned, and it is apparent both from the documentary and archaeological evidence that they were the most common type. In the Elizabethan Books of Rates stonewares were divided into two classes: those without covers, valued at 5s. per 100, and those with covers, paying 23s. 5d. per 100 (Willan 1962, 20). The entries of values in the Foreign Port Books are entirely of the former value, showing that they were uncovered, but stonewares with covers did occasionally arrive from London: 18 dozen cups covered and uncovered are recorded in 1575 (PRO E.190.930/1). Stoneware bottles, probably Bellarmines, were sent from London as early as 1586 (PRO E.190.7/6); this is the only 16th-century reference to such vessels.

#### *Stoneware usage in the city, 1560–1640*

Stonewares are the most plentiful type of pottery recorded in probate inventories. Since they were cheap, those without mounts were not regularly listed, but the scattered references to them are sufficiently numerous to show they were very common. There is evidence of a variety of types. In the period between 1560 and 1600 stoneware cups are much the most common, outnumbering jugs by about eight to one in a sample of about

150 vessels whose forms are specified. After the 1620s, however, jugs are the most frequent type, as the excavated evidence also shows. References to stoneware bottles are surprisingly rare; a single example of four 'little stone bottles' is recorded in the house of a cooper in 1621 (OC 140). The inventories often distinguish large pots from small: for example 'great stoning potts' were listed in the cellar of a Devon squire in 1641 (Cash 1966, 59). More usefully, the description of the plate of Hugh Pope in 1569 includes a reference to a 'little white cup of stone', and that of Harry Maunder in 1563 also refers to a 'white stone Cuppe' (OC 12; Cotton 1888, 96). Presumably both were Siegburg stonewares; both had silver covers and so they may perhaps have been old vessels. The Maunder inventory also lists a 'great flanders Cuppe wth a cover' valued at 2s. (*ibid.*, 96) and presumably this was also a stoneware vessel (cf. Hurst 1964b, 142–3).

Valuations of stoneware are recorded in only a few inventories. In the late 16th century, stoneware cups were several times valued at 2d. each. For example, Anthony Robbyns had six valued at 12d. in his hall in 1584 (OC 12), and Robert Matthew four valued at 8d. in his kitchen in 1564 (Portman 1966, 94). Some items were more expensive: a 'big Stone Cuppe' was valued at 4d. in 1569 (OC 13) and a further stoneware vessel valued at 4d. is recorded in 1590 (OC 44). Eight 'little and great' stoneware jugs were appraised at 3s. in 1576 (OC 24). There are also one or two entries which value stonewares at considerably larger sums; one suspects that these had covers which did not receive mention in the inventories. Very few valuations are available from the early 17th century, but one of eleven stone jugs at 6s. in 1628 (OC 169) and another of two stone jugs at 1s. in 1608 (OC 99) may indicate that these, perhaps elaborate Westerwald wares, were considerably more costly. Even at 2d. each, the prices given here are three times greater than their valuations in the Books of Rates of the customs officials (Willan 1962, 20; 1610 Book of Rates), and may well have been realistic. If so, the cheaper stonewares may not have been much more expensive than earthenware cups. Their most numerous metal competitors seem to have been tin cups, valued at between 6d. and 1s. each for pint pots, and proportionally more for those of quart and pottle size (e.g. Cotton 1888, 95; Portman 1966, 106, 113, 116). Stonewares can hardly have been beyond the reach of any but the poorest Exeter men, and the inventories show that several of the less wealthy freemen had good collections. John Reve, for example, had eight stone cups, some of them covered, in his hall (OC 8). Reve was a brewer whose goods were valued on his death in 1566 at £28, a sum indicative of very modest affluence (cf. MacCaffrey 1958, 247–50). Nine stone cups were listed in 1570 among the pewter of Richard Taylor, a cordwainer of only slightly greater means (OC 17) and seven, some of them again with tin covers, in the house of William Farmer, a fletcher (Rowe and Jackson 1973, 105) of similar estate (OC 73). At the bottom of the social scale represented in the Orphans' Court inventories, the joiner Richard Hedgeland owned a stone cup valued at 2d. among his few possessions, whose total value was only £4 (Portman 1966, 98). An estate of this size should probably be classed as 'poor' (MacCaffrey 1958, 247–50). One might have expected that the great merchant houses would contain much larger collections, but no evidence of this was found. There are plenty of references to between six and twelve uncovered stoneware pots in these households, but not more. Since these inventories often list very large numbers of cheaper items such as wooden trenchers, it is hardly possible to attribute this simply to a lack of detail in the inventories, and the place of stoneware may to some extent have been taken by metal cups or more precious items.

The practice of providing metal covers for these pots must have been well-established by the 1560s, when Exeter inventories first survive in large numbers. One of the earliest, that of Edmund Whetcombe of 1565, lists five covered cups valued at 2s., a price which suggests the covers were of a cheap material. From the early 1560s at the latest, cups with both silver and silver-gilt mounts were widely used by Exeter men. Exeter was one of only a few provincial towns where these mounts were made and hall-marked. Two examples of such cups are drawn here (2931–2); others have been illustrated elsewhere (Clayton 1971, 185, Fig. 367b; Holland 1971, Fig. 34; Oman 1954, Fig. 24). The inventories show that stonewares were mounted in a variety of ways. The majority had only a cover, most commonly of silver but occasionally of tin or more rarely of silver-gilt (OC 22). Some had mouths and feet of silver but no covers (OC 86); examples with covers and feet but without mouths of metal are more common. Of 137 vessels whose mounts were described, 6 had tin covers, 87 were of silver, 35 were of silver-gilt or were partially gilt and only 9 were double-gilt. Those surviving in museum collections generally have a foot, mouth and cover, all richly gilded, and are therefore not at all representative of domestic use, even among the wealthy; the exceptional pieces of high quality have survived most plentifully.

These cups were among the most common items of plate in Exeter households. Amongst about 220 inventories of the period 1560–1643, 75 list one or more of these vessels; many others make mention of plate but give no descriptions of individual items. If the Orphans' Court inventories give a typical sample, it is very probable that well over half Exeter's freemen of this period owned at least one mounted cup. Only silver spoons occur more commonly amongst their plate. Those who had sufficient means to own a small collection of plate commonly possessed only a set of silver spoons and one mounted stoneware cup. The cup would often be the most valuable item; for example, the cutler Richard Mogridge died in 1576 leaving a moderate

estate valued at £70. His plate comprised two stoneware cups, each footed and covered with silver, valued at £2, and six silver spoons valued at £1 (OC 26). Among the rich merchants' goods, between three and six mounted stoneware pots were normally listed, one or two of which were often gilt or double-gilt; descriptions of sizeable collections of plate rarely fail to mention such vessels. The collection of alderman William Chappell is typical. He owned on his death in 1579

'Five stone Cuppes garnished and guilte cont. by estimacon 34 unce at 5s. the unce . . .	£8 10s.
one stone Cuppe wth a Cover and the mouth garnished with whit silver by estimacon 3 unces & halfe at 4s. 8d. the unce . . .'	16s. 4d. (Cotton 1888, 82).

He also had seven stoneware cups 'with Covers and without Cover' at his house at Broad Clyst (*ibid.*, 86). It will be seen that valuations were made according to the quantity and quality of the silver; since the mounts were fixed to the cup, this required an estimate of their weight. The mounts themselves sometimes show graffiti giving this weight faintly scratched on the underside of the base, probably for assessment in probate (e.g. 2931). The cup was rarely considered to merit valuation, but there were exceptions: William Lante for example owned a big stone cup with a silver cover; the cover was valued at 7s. 7d. and the cup at 4d. (OC 13). In the late 16th century the most valuable cups, those with both a cover and foot of silver gilt, cost about £2 to 50s.; silver-mounted vessels often cost about 30s. Those with covers of silver alone were regularly valued at about 8s., whilst tin covers were very much cheaper, valued at 4d. in one inventory and 6d. in another (OC 23, 73).

An examination of the distribution of stonewares in the rooms of Exeter households reveals a marked distinction between the covered and uncovered vessels. Those without covers were very largely in butteries and kitchens, in which rather more than 80% of the 121 examples listed were to be found; they occurred with equal frequency in these two rooms. Fifteen other uncovered stonewares were in halls, the majority of them in the homes of less wealthy men, such as Nicholas Glanfelde who left five such cups in his hall in 1583. His estate was valued at £34 (OC 33). Of the rest, four were in cellars, one in a parlour, and two, probably uncovered, in chambers. Evidence regarding the distribution of the covered pots is less plentiful, as they were generally listed as plate. Thirty-one instances of their location were found. Of these, the majority (18 examples) were in halls, and only six in butteries or kitchens, four of these having only cheap tin covers. Two were listed in cupboards, and there were others in studies, a chamber and a dining chamber. Evidently plain stonewares were kept with kitchen utensils or in butteries with the pewter and tin. Mounted vessels were publicly displayed in halls and were occasionally to be found in more private rooms.

The hallmarks on the mounts of stonewares surviving in museum collections have provided the traditional means of dating Elizabethan and Jacobean stonewares. The mounted plain Frechen jugs belong almost entirely to the years c. 1560–1600 and so they are generally regarded as typical of the second half of the 16th century (Hurst 1964b). However the Exeter inventories show that stone cups with silver and silver-gilt covers were still equally numerous in the 1620s and 1630s. Sadly, the loss of the later 17th-century inventories precludes an examination of the subsequent demise of this kind of plate, but it is clear that mounted cups were in general circulation at least a generation after the latest dated examples surviving above ground. It is possible that early 17th-century examples were not sufficiently sumptuous to have survived, or that Elizabethan vessels were still in circulation a generation later; perhaps the latter alternative is the more likely. In either case, the mounted plain Frechen jugs must still have been in widespread use in the 1630s, and their mounts must have been a considerable factor in their survival to a later period still. This must call into question the value of these jugs as late 16th-century type-fossils; it may also explain the somewhat surprising quantity of such vessels in the richer pit groups of the mid and late 17th century at Exeter.

#### *Stoneware and earthenware importation, 1603–1660*

After 1600 the evidence regarding indirect stoneware importation becomes more sparse. The long series of Town Customs Accounts ends in 1603; a few of these documents survive from the reign of James I, but they contain little detail. More important, it becomes impossible to follow the levels of stoneware imports from London in the Coastal Port Books. In 1601 and 1602 the 32 recorded cargoes of pottery sent from London to Exeter were all stonewares (MF 48). These were the last years in which the import of large quantities of stonewares from the capital was recorded. They continued to be sent via London — for example five maunds are recorded in 1624 (PRO E.190.945/11) — but the specific references to them become less frequent. Instead, the books list very large cargoes of mixed 'pottery and glass'; this change may reflect a transformation of the London ceramics trade, with a growth in the shipment of delftwares and local earthenwares (below).

In c. 1600 changes were also made in the method of accounting stonewares imported from abroad: they

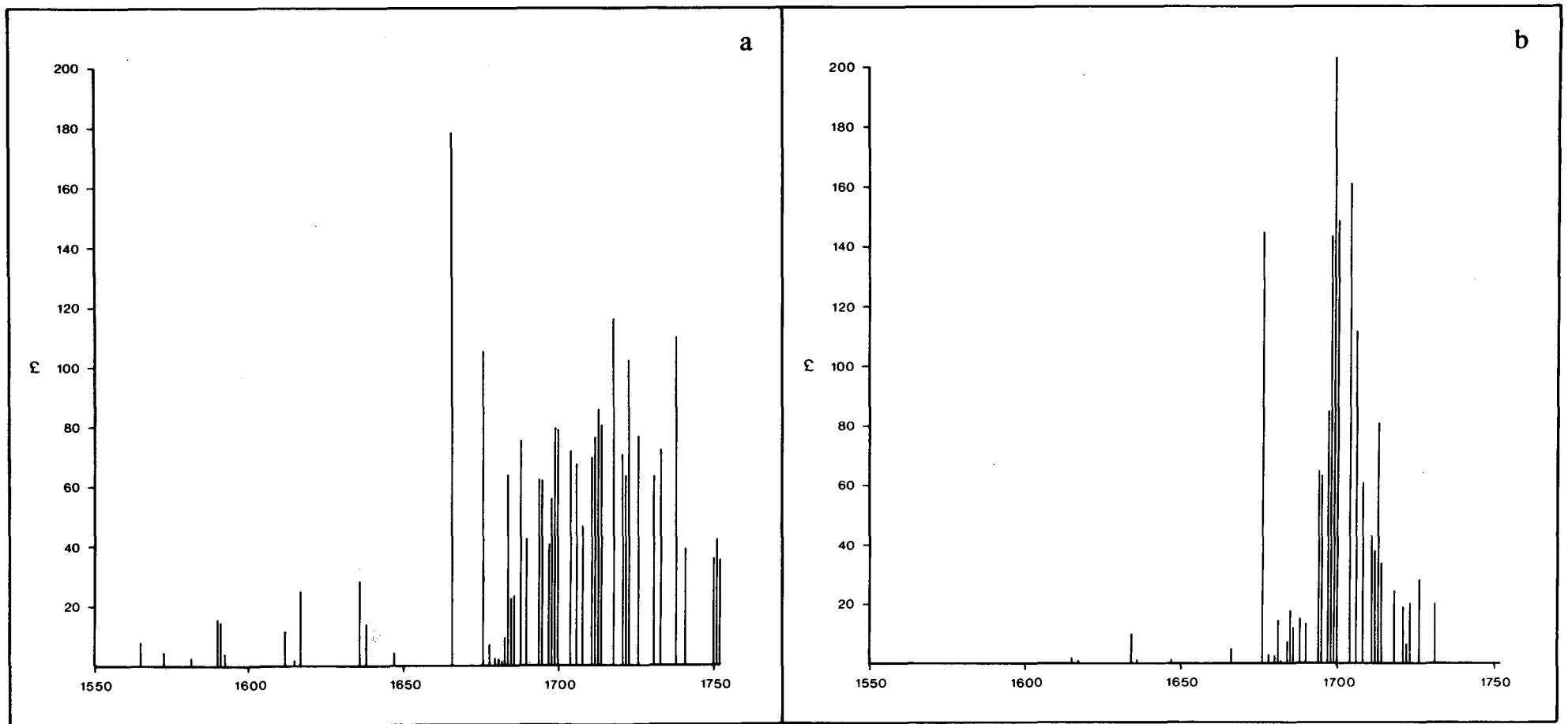

Fig. 58. The contrasting patterns of (a) stoneware and (b) earthenware importation from the Low Countries, 1565–1756 (source: PRO E.190. Exeter Foreign Port Books; DRO Exeter Town Customs Accounts).

were now counted in cast,<sup>4</sup> not by numbers of vessels. In the period 1600–1660, the eight surviving Foreign Port Books record the import of 4495 cast of stone pots, an average of 562 cast per year. The highest recorded annual totals were of 1505 cast in 1617 and 1200 cast in 1636. It is probable that large quantities of stonewares were still sent via London.

The early years of the 17th century also saw changes in the ports directing the Low Countries trade to Exeter. By the second decade of the century Middelburg had ceased to dominate the trade so completely, and several stoneware shipments were made from Flushing, with others from Dordrecht, Ostend and Dunkirk. In the 1620s Rotterdam first appeared in the Port Books, and thereafter it controlled Exeter's foreign ceramic trade for rather more than a century. With the exception of a single cargo of stoneware from Amsterdam in 1638, all the stonewares and earthenwares sent in the 1630s and 1640s came from Rotterdam.

Whilst prominent Exeter men continued to have the greater share of this trade, their dominance was not absolute. Indeed in the three years between 1612 and 1617 with surviving Port Books, the majority of entries were made by two alien merchants, Peter Johnson and Arnot Michelson. Michelson's ship the *Virgin of Flushing* made the journey from the Low Countries four times in 1617, twice returning directly with Devon dozens and Spanish iron, and on the other occasions returning via Dover and Southampton (PRO E.190.943/10).

These years were also the first in which Low Countries earthenwares are recorded coming into the city. The documentary evidence shows that as late as 1600 this trade was insignificant compared with that in stonewares. Only a single reference to the import of earthenwares is present in the Elizabethan books: in 1580 one maund of 'gally pots' was sent from London, perhaps of Low Countries origin but possibly from a more distant source (PRO E.190.932/12). By the second decade of the 17th century Low Countries earthenwares were coming into general circulation: the entry of several hundred earthenwares was recorded in 1615 and 1617, and again it may be assumed that more were re-exported from London. No distinction is made in the Port Books between delftwares and Low Countries or German slipwares; the archaeological evidence shows that both were arriving in the city, although the former were much more common.

#### *Stoneware and earthenware importation after 1660*

After the Civil War Exeter's direct trade with the Low Countries grew rapidly, and with it the volume of direct imports of stonewares and earthenwares. Their carriage via London appears to have ceased, since none of the very large number of Coastal Port Books of the period 1660–1750 contains a reference to the arrival of stonewares from London. This strongly suggests that the stoneware production of London had a negligible impact on the Exeter market, and when the origin of excavated sherds is uncertain, a Rhenish source is altogether more probable than a London one.

The first two surviving Port Books after the Civil War record notably high levels of ceramic imports. In 1666 the Exeter merchant Henry Gandy brought one shipment of 861½ dozen stone jugs, valued at £144 (PRO E.190.954/7). This was much the largest stoneware cargo recorded in any Exeter document. In that year a total of 12,854 stoneware vessels was imported. The pattern of importation in 1676 is probably more typical: in that year earthenwares valued in total at £145, plus 216 dozen stone bottles and 4158 cast of stone pots, were shipped to the city. With the exception of one stoneware cargo of 3000 cast, none of the ceramic shipments of this year was unusually large: the earthenwares came in 32 different cargoes, the largest valued at £11. The total value of the stoneware was £105, so the earthenware trade had evidently become the more lucrative. It is unfortunate that more Port Books of the period 1650–1675 do not survive to show whether this volume of imports was typical of the period.

As Toppin (1935, 40) has shown, the rise in the earthenware trade to England at this time brought a hostile reaction from London potters, and in 1672 a proclamation banning the import of painted earthenwares was issued. It is apparent that, at Exeter at least, this proclamation was not enforced four years later (above) and the London potters could justifiably complain in 1676 of the large quantities of earthenware arriving in England. A second proclamation issued in December of that year, again prohibiting imports (*ibid.*), evidently was enforced at Exeter. Earthenwares valued at only £3 were listed in the Foreign Port Book for 1678 (PRO E.190.957/3). In 1680, only two entries were recorded, the first of two maunds of earthenware for the private use of the importing merchant, the second of two dozen 'white earthen plates' for the private use of the customs officials; their entry was allowed only when the wares were for private consumption (PRO E.190.958/8). The proclamation had not specifically forbidden the trade in stonewares, but the Exeter Port Books show that their entry was also restricted: in four years' books up to 1682 only very small quantities, totalling 150½ cast and 65 dozen vessels, are recorded. These were the years of prosperity in the Low Countries trade when the importation of many other manufactured goods was at very high levels (Stephens 1958, *passim*), so the near-absence of entries of stoneware is striking.

The prohibition of painted earthenwares was not lifted until 1775, and Toppin was able to find occasional

examples of its enforcement. From this he concluded that the arrival of Dutch delftwares must have been effectively prevented, and that 'by far the greater part of delftwares found in this country belonging to the period 1672–1775 must be of English and not Dutch manufacture' (Toppin 1935, 40–1). Whilst more modern authorities have not assumed this was so (e.g. Ray 1968, 37), Toppin's claim seems not to have been seriously challenged. The entries in the Exeter Port Books do not support his contention. In the 1680s the levels of both stoneware and earthenware imports began to rise (Fig. 58; MF 49 and 51). Stonewares recovered the more quickly, returning to over 4000 cast by 1688. At first cargoes were very small. In 1683, for example, there were 22 cargoes, but none contained more than 50 cast and nearly all were brought by different merchants (PRO E.190.961/5). Perhaps they were, ostensibly at least, for private use, although this is not stated in the Port Books. Large earthenware cargoes began to arrive only in the 1690s but by the end of that decade had surpassed the level recorded in 1676. In 1699 earthenware imports were the highest ever recorded at Exeter, being valued at £203 (PRO E.190.973/2). Again, this is considerably more than the contemporary value of the stoneware trade, which in the same year would have been about £64, increasing to a peak of about £89 in 1718. The rise in earthenware sales is remarkable when the sharp rise in taxes upon it is considered: in 1657 an additional tax on both earthenwares and stoneware of 2s. per-pound was added to the old subsidy of 1s. (Toppin 1935, 39). In 1694 an additional impost of 2s.6d. per pound less 5% was levied, and according to the Port Books of the late 1690s earthenwares were paying import duties totalling about 27% of their customs value (e.g. PRO E.190.975/3). After 1699 the imports of earthenwares from Holland declined steadily, falling to less than a third of their maximum level by the end of the next decade. In the early 1720s they declined further, to about a tenth of the level of 1699, and in the early 1730s references to importation cease: there are no entries at all in six Port Books of the years 1733–52. This decline must reflect the success of English delftware manufacturers in competition with the Dutch. However Dutch earthenwares may have arrived in small quantities in the mid 18th century: the accounts of the Inspector General of Imports and Exports record the arrival of Dutch earthenwares at the outports at least as late as the 1770s (Toppin 1935, 54–5).

Most entries in the Port Books simply list earthenwares without specifying the type being imported. There are occasional references to coarse earthenwares (in 1690), unpainted ware (in 1696) and earthen plates (in 1678, 1681 and 1684) but these references are not very informative as it is well-known that these types were being sent to England. More interesting, the books record the arrival of some types of pottery which have not yet been recognised from excavations in this country. In 1683 16 dozen small stone ink bottles were brought to the city (PRO E.190.961/5). In 1684 six 'earthen stills' valued at £10 were sent, and in 1685 there followed 25 'caps for stills' (PRO E.190.962/4; 963/1). The entries of six 'earthen caps' valued at £2 in 1714 and another six weighing 40 lb. in 1726 (PRO E.190.996/13; 987/5) are presumably also references to 'caps for stills', i.e. alembics. Their valuations are consistently high, and if the last reference is accepted, they were evidently heavy; perhaps they were for commercial rather than domestic use. In 1699 there is one reference to the import of a jar and two flowerpots valued at £2; 'garden pots' were brought in 1708, and further flowerpots in 1690 (PRO E.190.973/2; 981/5; 966/8). The high price in the first entry suggests that these may have been ornamental items, perhaps like those from Basing House (Moorhouse 1970, 87–90). More surprisingly, several earthenware statues were sent from Rotterdam. Two 'earthen images' valued at £4 were listed in 1685; in 1686, one 'statue of earthenware' was valued at £2, and another sent in 1688 was appraised at 10s. 8d. (PRO E.190.964/1; 965/1). A batch of six 'images' brought with some stoneware in 1684 and valued at £1 may be a further example (PRO E.190.962/4). Finally, sugar moulds and sugar pots were sent in 1680, 1681 and 1711; these are discussed below (pp. 138–41).

The stoneware trade did not experience such sharp changes of fortune as the Dutch earthenware trade. The yearly averages of recorded stoneware imports per decade were as follows:

	Cast of stone pots	Dozens of stone bottles	No. of years in sample
1680s	1081	41	8
1690s	3286	14	6
1700s	3877	10	4
1710s	4391	74	5
1720s	3771	87	4
1730s	4028	89	3
1740s	1737	60½	1
1750s	1870	42	3

Table 16: Yearly average importation of Rhenish stoneware per decade, 1680–1756 (source: PRO E.190. Exeter Foreign Port Books). Note A few miscellaneous imports are excluded (MF 50).

There is no sign that the severe slump in the city's Dutch trade after 1713 (Hoskins 1935, 74–8) affected this particular branch of the trade. Indeed some of the largest yearly totals arrived during the slump in Exeter's fortunes: over 5000 cast were recorded in 1718, 1723 and 1738. The Rhenish stoneware trade to the city was apparently little affected by the early growth of the English stoneware industry, but after 1740 it declined, despite a revival in the fortunes of Exeter's Dutch trade in the mid 18th century (*ibid.*, 78–80). The Port Books provide some information regarding the types of stoneware imported. 'Stone pots' were assessed separately from 'stone bottles'. As Table 16 shows, the importation of bottles became an increasingly important aspect of the stoneware trade during the 18th century, particularly after 1720. It is evident that they were usually empty.<sup>4</sup>

Whilst the Dutch trade with Exeter was at its height it was conducted almost entirely through Rotterdam: many hundreds of ceramic cargoes were sent from there in the late 17th and early 18th centuries. However Rotterdam lost control of the trade late in the 1720s: in 1726 it was still the only source of Low Countries goods at Exeter, but by 1731 Amsterdam was sharing the trade, and by 1733 it was from Amsterdam that all shipments were made. Rotterdam appears only rarely in subsequent books.

As Stephens and Clark have shown, nearly all the merchants involved in Exeter's Dutch trade were local men, most of them from Tiverton and Exeter (Stephens 1958, 156–61; Clark 1956, III, xxviii) and it was these men who made all the ceramic shipments. Typically, a large number of different merchants would each take a few hundred pots amongst their mixed cargoes of linens, soap, tar and household goods. Often several merchants would each have ceramic cargoes in the same ship. For example in April 1690 the *Three Brothers*, the *Hopewell* and the *Endeavour* arrived from Rotterdam. George Hodder had 250 cast of uncovered pots and 24 dozen stone bottles with much else on the first ship. Over a period of rather more than a month, seven other merchants registered flowerpots, Flemish drinking glasses, earthenwares and bricks from the other two ships. In that year 27 ceramic cargoes were sent by 20 different merchants. Rather surprisingly, the rapid growth of the Dutch ceramics trade in the 1690s brought the temporary specialisation of two individuals in ceramic imports. The first, Thomas Toosloe, was a member of a Topsham family (PR Topsham); the second, Ann Lee, has not been traced. By 1697, the names of Toosloe and Lee become prominent amongst those of merchants importing ceramics, and by 1698 they brought in 22% of the earthenwares and about 30% of the stoneware. In 1699 Ann Lee alone imported earthenwares valued at £116 10s., i.e. 57% of the total. In this year she merchanted all the large earthenware cargoes including one valued at £20 10s. and three at around £15 each. In 1700, with the Dutch ceramics trade at its height, Lee and Toosloe had an even larger share of the market, with 92% of the earthenware and about 95% of the stoneware imported. Neither imported any other foreign goods in that year. Several shipments were made jointly by the two merchants, so they seem to have worked, on some occasions at least, as partners. Most of the other merchants who commonly imported ceramics in the 1680s and 1690s were not doing so in these years, despite the growing scale of imports, and one wonders how Lee and Toosloe came to corner the market so effectively. With the decline in the earthenware trade after 1700, they evidently ceased to rely so completely on ceramic imports. In 1704 their share of the earthenware shipments was still 74%, but they imported only about 40% of stonewares. Ann Lee was interested in other cargoes, such as Holland duck; Toosloe was also involved in the London trade. In 1707 he was shipping mixed cargoes of London goods including tobacco, linen and glass in his ship the *Hopewell*, but his interest in ceramics continued for many years. As late as 1723 he imported 1740 cast of stone pots, which made up 35% of the yearly total.

In the years after 1708 Toosloe sometimes worked in partnership with a second woman, Ann Eliot. Several cargoes of ceramics are listed in their joint names and she also came to specialise in ceramic imports. In 1718 for example, she shipped over 2000 cast of stone pots and 82 dozen stone bottles, and she and Toosloe together accounted for 75% of Exeter's stoneware imports.

#### *The total volume of imports*

Since so much documentary evidence survives at Exeter, one can at least make a crude estimate of the total quantities of stoneware imported here. In the reign of Elizabeth the average annual total was c. 4–5000 pots. We have no figures for the first half of the 16th century, but the archaeological evidence suggests that stonewares were just as common as in the latter half of the century, so a rough total of about half a million pots imported between 1500 and 1600 will not be an exaggeration. For the period between 1650 and 1750 it is unfortunate that the problem of the number of pots per cast has not been satisfactorily resolved<sup>5</sup>; in spite of the volume of evidence, the total levels of imports can be calculated only very crudely. The minimum number based on a cast of 1.2 vessels is again about 5000 pots per year. This is a cautious figure, and may require revision in the light of future work. For the intervening period between 1600 and 1650 we have too few figures to offer a total, but since these were years when imports at London reached their highest levels (Allan 1983a), it is unlikely that imports were lower. The total volume of imports over the years between 1500 and 1750 therefore will have been in excess of 1,250,000 vessels. Allowing that an unknown volume of



imports escaped record, and that the number of pots per cast may be considerably greater than that used here, the true figure may have been as much as twice that total.

When the recorded volume of imports is compared with the excavated sample, the documentary evidence underlines the very small size of that sample. At Exeter, where 35 excavations have been conducted in the city and its marketing area, about 1150 stoneware vessels have been excavated, and most of these are represented only by a few sherds. They form 0.1% or less of the total imported. This may give some indication of the kind of proportion excavated in other ports where major excavations have been conducted.

#### NOTES

1. Maunds were large baskets. The Books of Rates of the customs officials of the late 17th and early 18th centuries distinguished great maunds weighing more than 3 cwt from small maunds weighing less than 3 cwt.
2. The word 'cup' is regularly used in the Town Customs Accounts to describe cargoes called 'stone pots' in the parallel entries in the Exchequer Port Books.
3. Their origin is not in fact stated, but since the cargoes are not mentioned in the Coastal Port Books of those years and the number of pots was counted, it is almost certain that these are direct imports.
4. When stonewares and earthenwares arrived at Exeter from the Low Countries, duty was paid only upon the pots themselves.
5. The Books of Rates of the late 17th century defined a cast of earthenware as 'containing a gallon, whether in one pot or more'. It is very difficult to know how many pots this might mean on average. In the Books of Rates of the early 17th century a cast of pots was rated at five times the price of a pot. However in the late 17th century a cast of stone pots was commonly valued at c. 1.2 times the cost of a stone bottle. The latter multiplier has been used in estimates of the volume of imports between 1650 and 1750, but it may be too small a figure.

## 5. THE ENGLISH WARES

### A. THE LONDON WARES

#### *Delftware*s

In the early 17th century, London delftware seem far less common than those from the Netherlands (Table 6) and only three mauve-speckled mugs (as Garner and Archer 1972, Pl. 6) can be attributed to the capital. Obviously some of the simpler vessels, such as the drug jars, and fragments whose sources are uncertain, may also be London products.

These wares first become common finds in the 1660s, 1670s and 1680s, when imitations of Chinese designs (2103, 2292, 2835), products decorated with *bleu de Nevers* (Persian blue) glazes, and large quantities of plain white wares (e.g. 2293–2311) arrived at Exeter (Table 6). The late 17th-century groups contain a noticeably higher proportion of plain white wares than do those of the early 17th century (e.g. 2291–2311), and this cheaper type of delftware seems largely to be of English manufacture. Many of these wares are closely paralleled among the kiln waste from Lambeth (e.g. 2298, 2301, 2388; cf. Bloice 1971, 124, Fig. 54, Nos. 55–62). It is surely probable that London was the principal source of these vessels. Sadly, with the development of a number of English factories in the early 18th century, it becomes increasingly difficult to make specific attributions from fragments such as those from Exeter, and the popularity of London wares in relation to those of Bristol, Liverpool and other centres cannot be reconstructed with any precision. However it is probably significant that very few of the 18th-century English pieces whose place of manufacture can be suggested are London wares. The provincial kilns, especially those of Bristol, may have taken an increasing proportion of the market, although the documents record the arrival of pottery from London as late as the 1750s (below).

#### *Surrey-Hampshire wares*

The Surrey-Hampshire potteries made very little impression on the Exeter market in the 16th century: only 0.2% of sherds dating to the first half of the century are 'Tudor green' wares, and some of these could be French. Only a few more are present in the period 1550–1600, and several of these come from GS L.16–18 which contains intrusive material. This is the earliest series of deposits from which stratified examples of the yellow-glazed white wares made in Dorset, Hampshire and Surrey have been excavated. Visual examination of Verwood-type wares from Dorchester, Southampton and Poole, and of Surrey-Hampshire wares from London, suggests that most Exeter sherds of this class are closest in fabric to the wares from London. The documentary evidence shows that earthenwares came in very large quantities from the capital, whilst none is listed as coming from the ports of Hampshire, Dorset, Sussex or Kent (below). It is probable therefore that most of the yellow-glazed white wares from Exeter are Surrey-Hampshire products imported from London.

These wares appear to become more common in the early 17th century. Whilst the excavated sample is too small to be reliable, this conclusion appears to be corroborated by the evidence of the Port Books, which record very little earthenware exported from London before 1600 and rapidly increasing quantities thereafter (below). In the period *c.* 1600-50, most vessels are of forms which are likely to have been imported for use, rather than as containers (porringers, bowls, pipkins and a cup); this is also true of the larger collection from Castle Street, Plymouth, with its impressive number of cups and porringers (Gaskell Brown 1979, 4-5). The Exeter collection of the second half of the century is very different, nearly all the vessels being small drug jars. These must surely have come as containers, particularly as the finer green-glazed Surrey wares are rare here. It seems likely that they reflect London's role as a supplier of apothecary wares, to which the Exeter Port Books make repeated reference. There is no evidence that Surrey-Hampshire wares arrived here after *c.* 1720 (Table 17).

	No. sherds	Min. No. ve.	% of all ve.	Tudor green ve.	Yellow-glazed ve.	Surrey green-glazed ve.	Brown-glazed ve.	Jugs	Tripod pipkins	Porringers	Bowls	Drug jars	Encrusted cups	Other forms	Poss. Verwood type (ve.)
<i>c.</i> 1500-50	4	3	0.2	3											
<i>c.</i> 1550-1600	8	7	0.5	2	5										
<i>c.</i> 1600	34	5	5	1	2	2			3		1				
<i>c.</i> 1600-60	30	10	1.7		3	6	1	1?		2	1	2		1	
<i>c.</i> 1640-70	13	10	3		9		1		1?			3	1		
<i>c.</i> 1670-1700	41	23	2.5		22	1			1			5		1	
<i>c.</i> 1690-1720	83	24	2		22	1	1					7		1	
<i>c.</i> 1720 +															1
Unstrat., undated.	97	43		8	30	4	1		2	4	3	18		4	1
<b>Total</b>	<b>310</b>	<b>125</b>		<b>14</b>	<b>93</b>	<b>14</b>	<b>4</b>	<b>1?</b>	<b>7?</b>	<b>6</b>	<b>5</b>	<b>35</b>	<b>1</b>	<b>7</b>	<b>2</b>

Table 17: Surrey-Hampshire wares at Exeter, *c.* 1500-1750.

#### *Documentary evidence*

Of all the ceramic trades, that of the London wares is the least illuminated by a study of the Port Books. Every book of the 17th and early 18th centuries records the arrival of large quantities of ceramics, but pottery and glass were normally listed together in a single entry, and no distinction was drawn between continental stoneware or other pottery re-exported to the provinces, and wares made in the London area. Further, the pots were sent in a wide variety of containers; for example in 1627 a total of 21 chests, 19 baskets, three maunds, three barrels, two vats and one case of pottery and glasses arrived from London (PRO E.190.946/9). This clearly represents a large quantity of ceramics, but most of the units were of variable size, so the volume of the trade cannot be measured. However, a few conclusions can be suggested. First, the London trade appears to have changed markedly in character in the years shortly after 1600. In the Elizabethan accounts, London's recorded pottery exports to the South-West were almost entirely re-exports of stonewares; this appears to have been the case as late as 1601/2 (p. 118). In the accounts after 1605, mixed loads of pottery and glass make up the majority of entries, and by the 1620s a sizeable proportion of the entries

were of 'earthen pots'; earthenware was apparently becoming an important aspect of the trade. This may perhaps reflect the rise of delftware production in London and on the continent or the growth in the popularity of German slipwares and earthenwares. Some of the earthenware arriving from London must have been Surrey-Hampshire pottery (above); since coastal transport was so much cheaper than that by land (Willan 1976, 1-14), these wares will almost certainly have come by sea to the South-West via London (above).

The London trade seems to have grown markedly during the early years of the 17th century. By the 1630s, the number of cargoes of pottery and glass averaged over 120 each year, compared with about 40 to 60 in the years around 1600. Similarly high levels of imports are recorded in the 1660s. In the 1670s, with much of the Dutch trade coming to Exeter direct, the Coastal Port Books indicate that the London trade was still a major one. For example in 1672 20 cwt of pottery wares, 16 chests and baskets of earthenwares and seven more loads of mixed pottery and glass came to Exeter (PRO E.190.955/4). The trade continued to be the most frequently listed in all the Coastal Port Books as late as 1710 (PRO E.190.983/15; 984/9). In the books after 1717, however, Bristol cargoes become more common (PRO E.190.990/4; 990/15). By this time most entries distinguished pottery from glass; in the period 1720-50, recorded levels of pottery imports seem to have been static, averaging 20 to 30 crates, baskets or hogsheads.

## B. THE BRISTOL-STAFFORDSHIRE WARES

The pottery industries of Bristol and Staffordshire made little impact at Exeter before *c.* 1700: less than 1% of stratified sherds of *c.* 1670-1700 are from these centres and even in the groups of *c.* 1690-1720 the proportion is still very low. The much larger numbers of stratified vessels in deposits of *c.* 1720-40 suggest a rapid growth in the importation of these wares and this corresponds well with the documentary evidence, which enables the growth of the trade to be seen with more precision (below).

The yellow slipware cups from these centres form the bulk of the early finds, but they were clearly in circulation for a long time at Exeter: examples range in date from the opening years of the 18th century (e.g. in FG 107) to those stratified with transfer-printed wares of the end of the century (unpublished). They must have gone out of use before *c.* 1820 since there are none in the very large group GS 218 (unpublished). By contrast, the treacle-brown glazed tankards show a pronounced *floruit* between *c.* 1720-40, with very few later examples. As one might have expected, the plain white salt-glazed stonewares far outnumber all the other classes of Bristol-Staffordshire wares in mid 18th-century groups. The most common of these were press-moulded plates, but a wide variety of other types is also represented in the collection.

	No. of Bristol-Staffs. sherds	% of all sherds	% of all ve. (Min No.)	Yellow slipware (ve.)	Treacle-brown-glazed (ve.)	Press-moulded dishes (ve.)	Brown stoneware (ve.)	White engobe stoneware (ve.)	True white stoneware (ve.)
<i>c.</i> 1660-1700	2	0.1	0.5	1					
<i>c.</i> 1690-1720	64	1.5	5	19	8	3	9	1	
<i>c.</i> 1720-40	137	11	15	13	17	8	7	1	
<i>c.</i> 1740-70	662	23	26	29	4	11	5	1	108

Table 18: Bristol-Staffordshire pottery at Exeter, *c.* 1660-1770.

### *Documentary evidence for the trade from Bristol*

The arrival of pottery from Bristol is first recorded in the Coastal Port Books of the 1670s; these wares could have been made either in Bristol or in Staffordshire. Since Bristol-Staffordshire pottery first appears in Exeter assemblages of about this date, the Port Books probably provide good evidence for the period of their introduction in any numbers into the city. In the early years of the trade the quantities recorded were quite small: for example, only four maunds were listed in 1672 and ten baskets in 1679 (PRO/E.190.955/4; 957/15); the references become quite plentiful only after *c.* 1710. At this time the earthenware trade was much less important than that in glass, and particularly glass bottles, or ironmongery. Pottery imports must have

grown rapidly in the next decade: in 1717, 102 crates were carried in a single year, and subsequently about 30 to 50 crates were transported annually by sea (Table 19). Importation does not seem to have grown in the 1730s and 1740s (Table 19); perhaps the trade in pottery from Bristol was suffering from the growth of the Staffordshire industry. It is also possible that Staffordshire products were being marketed to an increasing extent through Liverpool. However, in the 1750s the Port Books record much higher totals and since these correspond with a very sharp fall in the quantities of pottery sent from Liverpool, many of the cargoes sent from Bristol may have been Staffordshire wares. There are a few indications of the variety of wares imported: in 1752/3 100 *creasis* (crest tiles) and 3000 pantiles are recorded; in 1728/9 there is a single reference to the arrival of 'earthen sugar moulds', and in 1756 one batch of stoneware was brought from Bristol (PRO E.190.997/15; 1004/5; 1004/6; 1005/3; 1005/4).

#### *Documentary evidence for the trade from Liverpool*

The port of Liverpool first features in the Exeter customs records at the end of the 17th century, when cargoes of rock salt, dairy produce and Manchester wares were brought to the city. There is no mention of pottery amongst these goods, and the earliest imports from Liverpool were recorded in 1717 when six crates were listed (PRO E.190.990/15). The meteoric rise in this earthenware trade, particularly when compared to that at Bristol, is seen in Table 19.

	No. of years examined	Bristol	Liverpool
1700s	3	c. 4	Nil
1710s	3	38	2
1720s	2	38	43
1730s	3½	50	212
1740s	1	c. 34	267
1750s	2½	114	c. 40

Table 19: Yearly average importation of earthenwares from Bristol and Liverpool during each decade, 1700–60 (figures in crates). (source: PRO E.190. Exeter Coastal Port Books)

The bulk of the very large quantity of pottery brought to Exeter from Liverpool must have been Staffordshire wares, but it is likely that a few Liverpool tin-glazed wares are also represented in these totals. Buckley wares could also have come from Liverpool but there are no definite sherds of this type in the collection. Assuming that most of the pottery sent from Liverpool was made in Staffordshire, it is apparent that by the late 1720s the products of this industry had already outstripped those of Bristol in the Exeter market and were probably more numerous than the wares sent from London. By the 1730s Staffordshire products were about four times more plentiful than those sent from Bristol. By the 1760s, enormous quantities of 'china', probably largely Staffordshire wares, were coming into the city. In 1764 the *Exeter Mercury* advertised the sale of over 73 cwt of china, valued with a small quantity of paintings and glass at over £2000. The items included large jars, beakers, complete tea sets, bowls, basins, oblong and round dishes and plates, mugs, baskets and leaves, and china-hafted knives and forks (*Exeter Mercury* No. 47).

Some of the Exeter Port Books record the voyages of the ships delivering pottery to the South-West. For example, in 1733 the *Diligence* of Liverpool left its home port with 80 crates of earthenware. Three were unloaded at Padstow, another eight at Truro and a further ten at Plymouth; the remaining 59 crates were unloaded at Exeter (PRO E.190.999/15). No evidence that such ships were attracted by the need of the Staffordshire industry for ball-clay has been found; shipments of ball-clay from South Devon to Liverpool began only in the 1740s and became important only in the 1760s (Bulley 1955, 196, 204).

### C. THE NORTH DEVON WARES

North Devon coarsewares first appeared at Exeter in the early 13th century, but they are rare in medieval deposits and make up only 1% of the late medieval collection. The finds from Exeter provide useful evidence for the dates of emergence of the various post-medieval fabrics. The gravel-free ware with calcareous inclusions is already present in a group dating to the end of the 15th century (1543) and occurs in several early

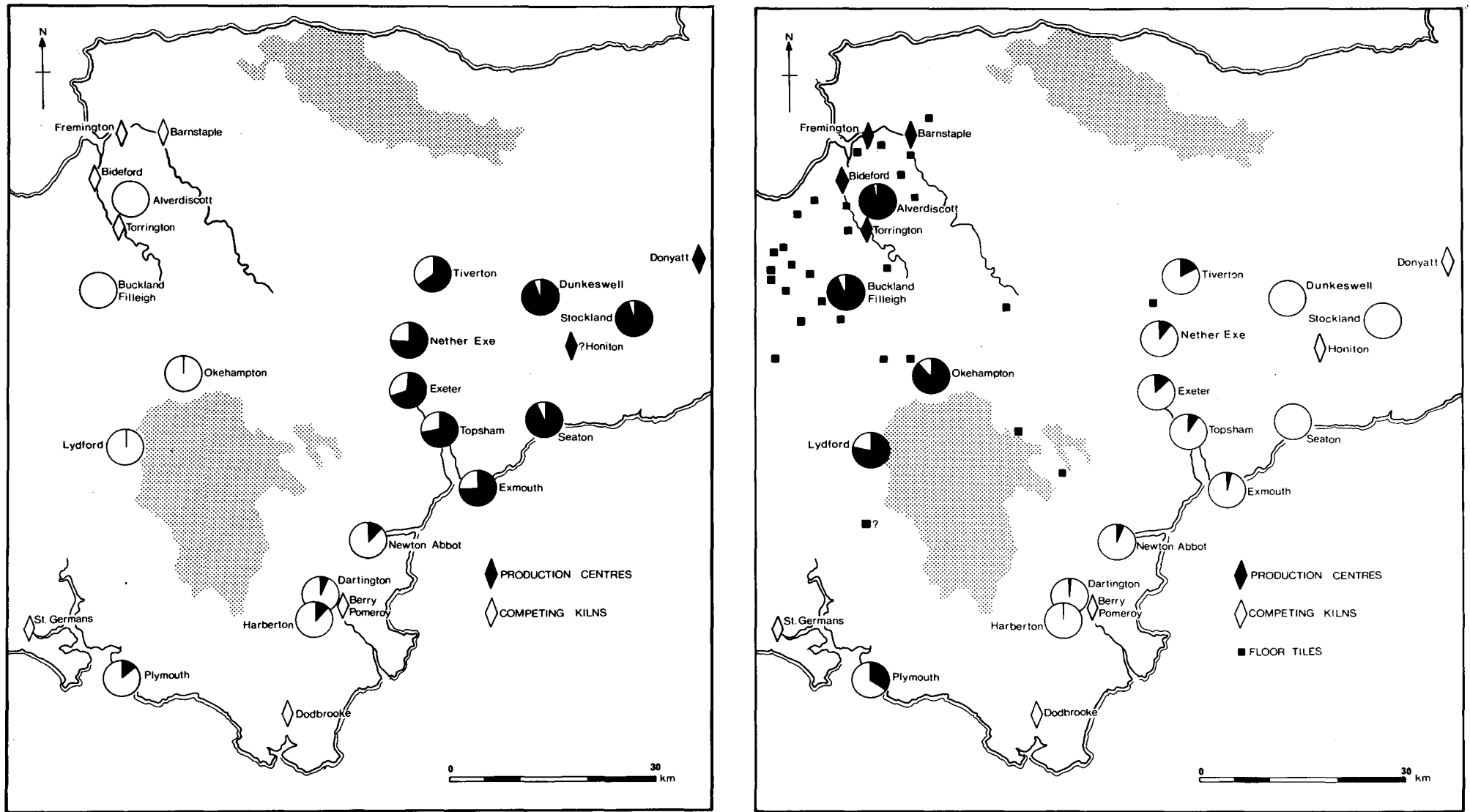

Fig. 59. Pie-diagrams showing (left) proportion of South Somerset wares and (right) proportion of North Devon wares in post-medieval pottery assemblages in Devon.

16th-century groups (GS 228, 264; QS 8, 16). Gravel-tempered ware is present in the Dissolution deposits at St Nicholas Priory (c. 1536–50) and may well have been in circulation before 1500; there are sherds of this type in the top layers of street metallage at Rack Street, where all the other sherds are late medieval in character, and further examples (1557–8) are in a group from the excavations of Aileen Fox at St George's church, apparently of late 15th-century date. To the writer's knowledge, these are the earliest stratified examples of these two common fabrics. There seems to have been some growth in the marketing of North Devon wares to the city in the mid 16th century: the groups of c. 1550–1600 contain over 60 of these vessels, rather more than 4% of sherds of this period, compared with c. 1% in the first half of the century. Nearly all the 16th-century sherds (over 90% of the total) are of the fine calcareous gravel-free type, and all the identifiable vessels are type 14 jars. The only published group of contemporary North Devon pottery, that from Okehampton Castle, likewise consists predominantly of fine gravel-free jars (Allan and Perry 1982, 101). The emphasis on coarseware production, particularly of bowls, may well have developed only after c. 1600.

The proportion of North Devon pottery present in the first half of the 17th century is surprisingly low (3% of the total), especially when compared with the quantities present in Plymouth at this time (about 50% of all wares in the Kitto Institute group). For this reason the Exeter collection provides no evidence for the date at which sgraffito-decorated wares were first made in North Devon. None is present at Exeter in groups dating before c. 1660 (GS 96), although it seems from finds elsewhere that the type begins in the period c. 1610–30 (for a summary of the evidence see Allan 1981, 132).

The years around the middle of the 17th century saw a rapid growth in the quantity of North Devon wares reaching the city (Fig. 60). This coincided with the cessation at about this time of the production of local Coarse Sandy wares, which had occupied a similar niche in the ceramics market; both potteries concentrated on the production of storage vessels and bowls. North Devon wares make up 18% of sherds in groups of c. 1670–1700 and 23% in groups of c. 1690–1720. The latter period saw their greatest penetration of the Exeter market and this coincides with the peak in seaward exportation of the wares known from documentary sources (Watkins 1960, 24–7, 29). Deposits of the second quarter and the middle of the 18th century contain consistently lower proportions of North Devon wares (Fig. 60), but this does not necessarily imply any great diminution in the volume of the trade: the new Staffordshire and Bristol industries may have brought much larger quantities of ceramics into households without adversely affecting coarseware production. Importation certainly continued at least as late as c. 1820, as an unpublished group (GS 218) from Goldsmith Street shows, but the percentage of North Devon wares in 19th-century assemblages is much lower. The precise figure has not yet been determined but it is probably less than 5%.

The proportion of North Devon wares in post-medieval assemblages from sites in Devon is shown in Fig. 59. Unfortunately many of the finds from outside Exeter are unstratified, and so the figure cannot be taken as presenting a true picture of the industry's market share at one particular period. Nevertheless, several general points emerge. As expected, North Devon, and especially North-West Devon, are dominated by local products, and most of the floor-tiles have been found in this area (Keen 1969). East Devon was supplied almost entirely by the South Somerset industry, and it is particularly interesting to see that at Exeter and Tiverton, which are approximately equidistant from Donyatt and Barnstaple, although closer to Honiton, the South Somerset industry had much the larger share of the market. In South-Central Devon some sites were supplied by local potteries, but the high proportion of North Devon finds both at Plymouth and Lydford suggests that the industry was more successful in competing against its Cornish rivals than against those of South Somerset.

The various forms were not supplied in equal quantity to each market. The absence from the Exeter collection of definite chill sherds, which are common enough in Cornwall (e.g. finds from various sites, in Truro Museum), presumably reflects the usage in this part of Devon of wax candles instead of the burning of fish oil in chills; this is confirmed by the plentiful finds of pottery candlesticks (e.g. 2226–9) and the documentary evidence both for chandlers living in the city (e.g. Rowe and Jackson 1973, 106, 108, 199, 202) and for the use of metal candlesticks (e.g. Portman 1966, 95, 97). There is not a single definite oven sherd in the collection, and they must have been rare here although not entirely absent: one survives *in situ* at Polsloe Priory, about two miles from the city, which in the 17th and 18th centuries was a farmhouse. Firedogs and firebacks are absent, and the illustrated floor tile (2866) is the only one known from South-East Devon. North Devon ridge tiles occur in several groups but do not seem very common; thus it appears that the heavy architectural objects did not find a significant market here.

By contrast, the proportion of sgraffito-decorated sherds in Exeter in the late 17th century is between two and three times higher than the estimated proportion at the North Walk kiln waste dump at Barnstaple (cf. Miles and Miles 1975, 290). Presumably the finewares, being lighter and more expensive, were better suited to long-distance trade. Alternatively, towns may have provided the largest market for the finewares, much of the coarseware being for agricultural use.

The dating of the individual North Devon forms is summarised in Table 20 which shows the heavy

concentration of examples at Exeter in the late 17th and early 18th centuries, but more usefully shows that some types had a very long life: types 3A and 10 for example were already in use in the late 16th century and are still present in mid 18th-century contexts.

Nearly all the stratified sgraffito-decorated wares belong to the years *c.* 1660–1700; their use at Exeter declined sharply around the turn of the century and by *c.* 1720 they had disappeared from circulation. The evidence from Exeter corresponds well both with Watkins' (1960, 34) conclusion that these wares went out of production in *c.* 1700, and with the absence of vessels bearing dates after 1700 in the North Walk kiln dump (T.J. Miles, pers. comm.). Sherds of the sgraffito-decorated harvest jugs of the years after 1700, quite common in museum collections, are unknown here and seem very rare in excavations elsewhere; their production must have been on a much smaller scale than that of the 17th-century finewares. There is however some evidence that the production of plain slipware continued until the mid 18th century (2661 and other sherds in groups of *c.* 1740–60).

	1A	1B	1C	2A	2B	3A	3B	3C	3D	3E	3F	4	5	6	7	8	9	10	11	12A	12B	14	15	16		
<i>c.</i> 1450–1500																									1	
<i>c.</i> 1500–50																									1	1
<i>c.</i> 1550–1600						a		a		a		a														6
<i>c.</i> 1600						2																				
<i>c.</i> 1610–30						b		b		b																
<i>c.</i> 1600–50																1		2								
<i>c.</i> 1640–70				2				1						1				4								
<i>c.</i> 1670–1700	2	2	11	10		1	1	2	1	1	2	4	3	4	1	1	6	1	1		?	1				
<i>c.</i> 1690–1720	3		7	9	?1	9	1	14	3		1	1	6	4	9			1	7	1			1			1
<i>c.</i> 1720–40				3																						2
<i>c.</i> 1740–70				6		1	2	1					1													1

Table 20: Dating evidence of the common North Devon forms.

(a) Present in Okehampton Castle 1582 (Allan and Perry 1982, 99, Fig. 47).

(b) Present in the Kitto Institute Well group, Plymouth.

#### D. THE SOUTH SOMERSET WARES

By *c.* 1500, pottery of the type made at Donyatt in South Somerset had become by far the most common class of ceramics at Exeter: nearly all the coarsewares of that date are of South Somerset type. It is currently unclear whether the popularity of Coarse Sandy ware at Exeter from *c.* 1500 to *c.* 1650 represents the establishment of a rival production centre (pp. 135–6) but after *c.* 1650 South Somerset products again formed by far the most common class of coarsewares in the city and they remained so into the 19th century (Fig. 60).

Why are they so plentiful here? Part of the explanation may lie in the good quality and great importance of the road eastwards from Exeter through South Somerset to London. Writing in 1698, Celia Fiennes described it as 'the best road I have met withall in the West' (Morris 1949, 271), a view supported by most other writers (Sheldon 1928, 75–6).<sup>1</sup> The road was much used in the overland haulage of Exeter goods, notably cloth, to London, and had a regular carrier service by the 1630s (*ibid.*, 60–137; Stephens 1958, 133). An additional advantage to the South Somerset potters may have been the alternative possibility of carriage by sea. The Coastal Port Books of Lyme Regis record regular exports of earthenwares to the ports of Devon and Cornwall in many years during the 17th and early 18th centuries (Allan 1983a, 39–41); these were presumably

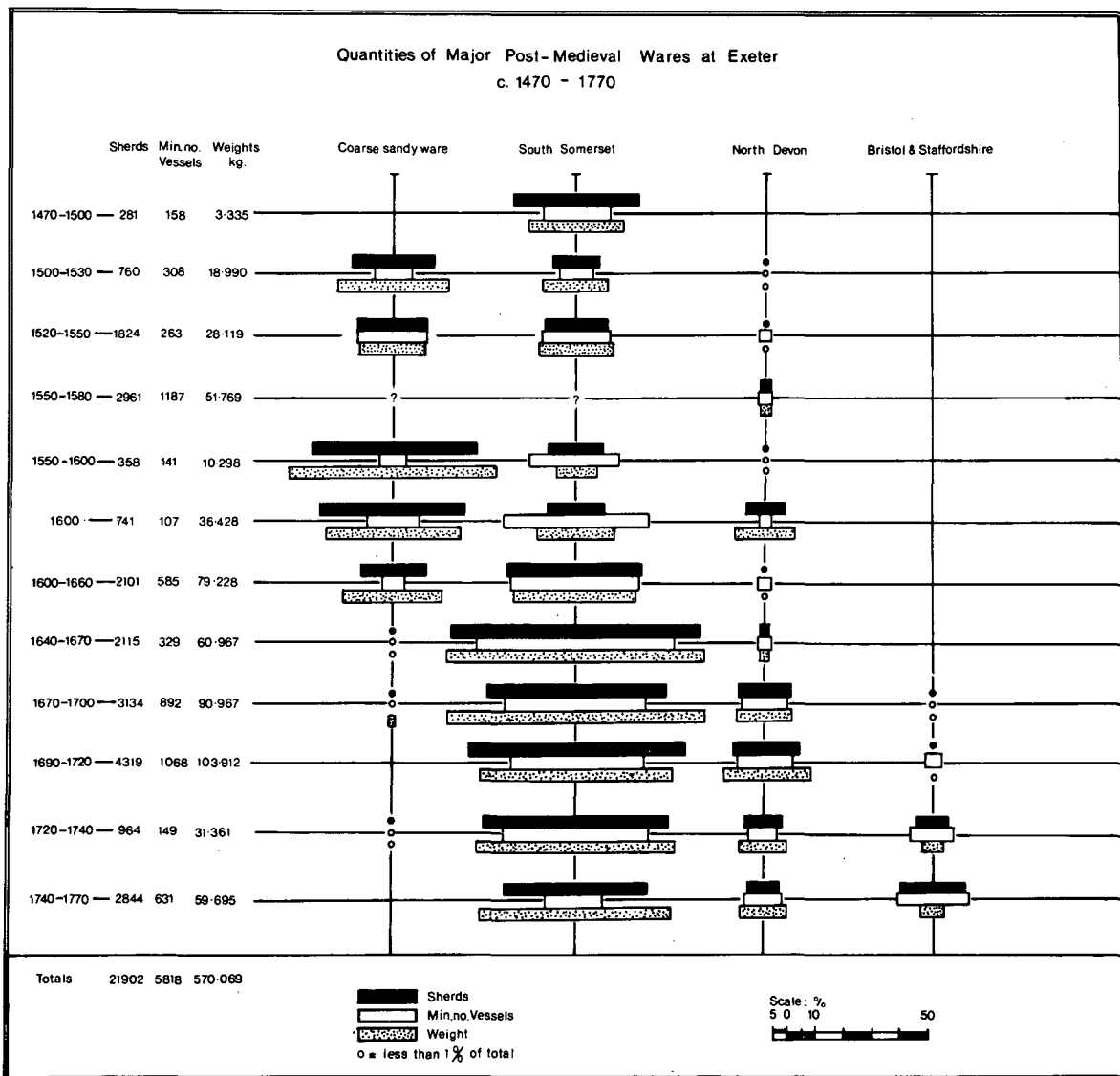

Fig. 60. The quantities and proportions of the major post-medieval wares, c. 1470-1770 (percentages and totals of complete assemblage).

Note: The groups of c. 1550-80 consist largely of small sherds; it has not been thought feasible to distinguish South Somerset from Coarse Sandy wares in this case.

the South Somerset wares which are common finds in Plymouth and have been found in Newton Abbot, Totnes and Dartmouth. However this route seems to have been little used in transporting pottery to Exeter; whilst Plymouth annually received hundreds or even thousands of parcels by this means, Exeter and Topsham received only a few dozen parcels. These will have supplied only a small proportion of the city's needs.

Further, there is the possibility that much pottery of South Somerset type was really made at Honiton in Devon (p. 98). This town is considerably closer to Exeter than any North Devon kiln (Fig. 59) and also lay on the main London road. It would clearly have been in a very competitive position to serve the Exeter market.

#### Dating

During the last 30 years very large quantities of South Somerset pottery have been excavated. Large mid 17th-century groups have been published from Taunton and Bristol (Hallam and Radford 1953; Barton 1964), and the major collections from Plymouth have been presented (Gaskell Brown 1979; Broady 1979). The wares of the early 18th century have recently received some attention (Pearson 1979) and many major late 17th- and 18th-century groups from Somerset are currently being prepared for publication (reports by T. Pearson forthcoming). The excavations at several kiln sites, notably at Donyatt, have amassed further large collections, and there have been several important recent finds at Bristol. Nevertheless, the Exeter series



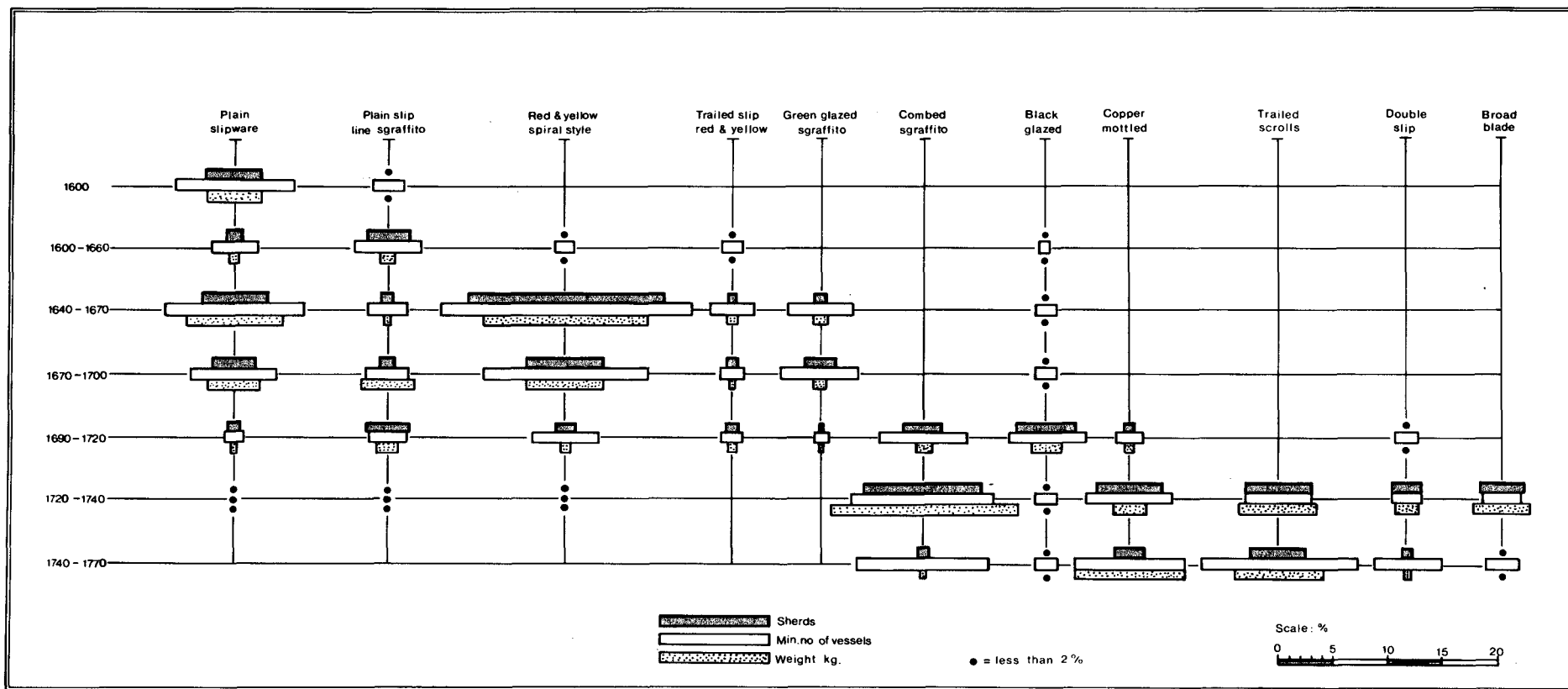

Fig. 61. The development of South Somerset decorative styles c. 1600-1770.

remains extremely useful in the study of South Somerset products. Here alone one can follow the succession of pottery types over the whole late medieval and post-medieval period, for at least four or five large groups of pottery from the city are attributable to every half-century between *c.* 1450 and *c.* 1800. The pre-*c.* 1650 material is of particular importance, since it is far more abundant here than elsewhere.

The pottery excavated at kiln site 3 at Donyatt was attributed to the early 16th century, since Raeren stoneware was found in one of the kiln mouths (*ex inf.* T. Pearson). The Exeter evidence amply confirms that the products of that kiln all occur in early 16th-century contexts. However, this evidence also shows that the production of the various vessel types made in the kiln did not begin simultaneously. Two types (Fig. 64, type 2A jugs and type 4 cooking pots) were in circulation during the late 15th century (818–20), and both types are present in the dump EB 898 which can probably be associated with the construction of the tower of St Edmund's church, Exe Bridge, in the 1450s. By *c.* 1500, a new range of forms had been added to the traditional repertoire: fine green-glazed cups (1541–2), jugs with twisted handles (type 2B) and chafing dishes (type 8). It is quite clear that the large coarse bowls (Fig. 64, type 1 and Fig. 67, type 1) appear in Exeter after the introduction of these new forms (p. 13) but since these bowls are so commonly found with the typical imported wares of the early 16th century they must have arrived shortly after 1500. There are also grounds for believing that many of these early 16th-century forms survived into the second half of the century. A series of vessels from Bishop Grandisson's tomb (1811–16) shows that all the typical early 16th-century jugs were in use in the third quarter of the century; there are further examples in other late 16th-century groups (1906, 1908, 1959, 1966). On the other hand, all the types shown in Fig. 64 seem to have died out by *c.* 1600, since there are none in QS 314 or in a series of similar deposits which must be broadly contemporary.

It is a pity that Exeter has produced no group firmly attributable to the last third of the 16th century, since this period appears to have seen a transition from the forms represented at Donyatt site 3 to those familiar in 17th-century deposits. By *c.* 1600 the products with the orange-red glaze which is typical of South Somerset pottery of the second half of the 17th century were already commonplace (e.g. 2004–12), and most of the coarseware forms seem to have remained much the same until *c.* 1700. There are, however, major differences between the decorative styles employed in the early years of the 17th century and those of its latter part. First, there is much less decorated slipware in groups dating to the period before *c.* 1650 compared to those of later date: such wares average only 14% of South Somerset sherds in early 17th-century groups, but 61% in those of the late 17th century. Second, there is a gradual change in the styles employed (Fig. 61). Plain yellow-glazed wares and those with simple line sgraffito patterns or copper-green splashes were all in use by *c.* 1600 (1999–2003). These are the main types of decorated ware of the first half of the 17th century. Conspicuously absent from most of the earlier 17th-century groups are the typical 'spiral' style sgraffito wares (Fig. 65, type 3A). The earliest example of this class from Exeter is in one of the deposits (HL 74) cut by the Civil War ditch at Holloway Street; this dates to the years before 1642. They are far more common between *c.* 1650 and 1700 (Fig. 61).

The subsequent changes in style are also summarised in Fig. 61. There is a pronounced change in pottery types around 1700, when a new range of forms, fabrics and glazes emerges. The pink and red wares of the 17th century are commonly replaced by buff-coloured fabrics, the red and brown glazes by greens with frequent orange blotches. These changes suggest the possibility of changed kiln techniques. The spiral-style dishes vanish by *c.* 1720 at the latest, and in their place a more rapid technique is adopted: the use of combed designs in wet slip. The number of groups with a mixture of 17th- and 18th-century types is quite small. Since so many groups of *c.* 1670–1720 have been excavated, this suggests that the life of individual vessels in a household was brief; very few pots made before *c.* 1700 were to be seen in the households of the 1720s.

Finally, two 18th-century styles are noticeably absent from the groups of *c.* 1690–1720: the vessels with trails of slip in scrolls and dashes (Fig. 66, types 2D, 4 and 6) and the 'broad-blade sgraffito' wares (2613–15). The second type is rather rare in excavations and seems to have been in use only for a short period, *c.* 1720–40. It may have been the product of a single kiln.

#### NOTE

1. However, even the best of Devon roads were poor in winter. When in the 1760s Exeter and Taunton sought their first Turnpike Acts, one M.P. claimed it would be cheaper to convert the roads into canals (Buckingham 1885, 1).

#### E. THE COARSE SANDY WARES

A large number of the coarsewares excavated in 16th- and 17th-century contexts at Exeter appear to belong to a distinct local type, here called Coarse Sandy ware. The characteristic features of the type are the coarse sandy fabric, the very common use of reduction firing producing dark green or brown glazes, and a distinctive range of vessel shapes (Fig. 67). The most distinctive of these products (e.g. types 2, 4–6, 9–10) have not been

found in any excavations in Somerset (T. Pearson, pers. comm.) and this ware is rare on other Devon sites, notably Okehampton Castle, Hole, Dartington Hall, Tiverton, Newton Abbot and Plymouth. It therefore seems possible that a production centre close to the city supplied these wares.

There are, however, complications in defining this class of ceramics since coarse sandy pottery was also made in South Somerset and bowls of forms 1A and 1B have been found among the kiln waste at Donyatt. Thus very similar fabrics may have been made both in Devon and Somerset. It is possible that Coarse Sandy ware represents one aspect of the production of kilns making both coarse and fine products.

#### *Dating*

This ware is not present in any medieval deposit at Exeter. Its absence from the large group of pottery from Polsloe Priory 1582 with its series of imports dating to c. 1500 provides strong evidence that the fabric did not come into circulation before that date; however it is common in all early 16th-century pit groups. The frequency of this ware in the 16th and early 17th centuries and its rapid disappearance in the years around 1650 are illustrated in Fig. 60. There are hardly any sherds in contexts of c. 1660–1700, despite their common occurrence a generation earlier. The presence of several Coarse Sandy wares in a group is therefore a useful indicator in distinguishing early 17th-century groups from those dating after c. 1650. There is no evidence that any of the forms of this ware are closely datable and the four common types (1A, 1C, 4 and 5) were all in circulation from c. 1500 to c. 1650 (MF 66).

### F. OTHER SOUTH-WEST ENGLISH WARES

#### *St Germans-type ware*

Sherds of St Germans-type ware (Gaskell Brown 1979) are rare at Exeter. Only 13 vessels are present in 16th-century layers, comprising about 1% of the stratified sherds of that date. Unglazed products of this distinctive type were already arriving in Exeter in the 15th century (EB 505) and there is a fairly even scatter of finds throughout the 16th-century groups. Glazed St Germans-type ware is already present in several groups in the first half of the century (e.g. 1834). No definite examples of this ware are present in 17th-century groups at Exeter.

#### *Totnes-type ware*

A highly distinctive local micaceous fabric was in common use in the area around Totnes. (Report by writer in prep.). It is probable that it was made at Bridgetown Pomeroy in the parish of Berry Pomeroy where there is documentary evidence of a late 17th- and early 18th-century pottery (*ibid.*). This fabric is rare in Exeter, with fewer than 10 vessels so far recognised, most of them represented by bodysherds. Definite examples range in date from the early 17th century (GSH 20) to the beginning of the 18th (2554). It is notable that this ware, which could easily have been brought to the city by a coastal trip of only c. 60 km (Fig. 53), occupied such an insignificant part of the ceramic market at Exeter.

#### *South Devon Micaceous ware*

This distinctive fabric, with its black mica plates indicative of a clay source derived from a granite area, is currently known only at Exeter. It is present in early and mid 16th-century deposits, which have produced a total of about 10 vessels, including several near-complete examples.

### G. THE KILN WASTERS FROM GOLDSMITH STREET (Figs. 69–72)

Two pits excavated in Goldsmith Street, site 3 (GS 264, 290) were packed with about 50 kg of pottery, most of it demonstrably kiln waste. Numerous pots were divided between these two pits, so their contents have been treated as a single group. The pots must come from an unlocated kiln in the vicinity, perhaps in the rear of the tenement in which they were found, which was not excavated.

These wares differ in many ways from other local products. First, there is a remarkable range of novel vessel types: at least 20 types of pottery were produced in this kiln and the flasks, plates, tall jars, rectangular dishes and candlesticks are forms not attested elsewhere in the South-West at this early date. Second, they display none of the common decorative techniques of south-western products of the end of the medieval period: there is no brushed slip, neither are there applied strips, twisted handles, crude sgraffito decoration or metallic strips. With a few exceptions (below) the specific features of handles, rims, feet, mouths, *etc.* bear no

relation to those of other local wares. Third, the shapes of the vessels are also completely different from any other local products.

Many of the features of the Goldsmith Street wares are paralleled among the redwares of the Low Countries. The tripod cooking vessels with pod feet (**1660-9**), often with rilling imitating metal forms, correspond to the *grapen* widely distributed in the Low Countries (e.g. Sarfatij 1972, 17, *afb.* 9; Trimpe Burger 1964, 104, *afb.* 9; *idem* 1974, *afb.* 16). They are comparable to vessels from Oudorp, Middelburg and Dordrecht (Renaud 1971, 63; Trimpe Burger 1964, 104, *afb.* 9; Sarfatij 1972, 17). Bowls very similar to **1643-7** with horizontal handles, collared rims and 'pulled' feet are known from the southern parts of the Low Countries and from Flemish paintings (e.g. Renaud 1959a, 208, No. 1; Brears 1971, 27). Turning to the specific features of their forms, the use of thumbed strips as seen on **1620-2** and **1686-7** is paralleled among the 15th- and 16th-century pottery published from Mariendael near Utrecht (Renaud 1959a, 207, No. 3). The collared rims of jugs (as **1628-37**) and the use of thumb-marks on each side of a rod handle at the rim (e.g. **1640**), or of one or three thumb-marks below the handle (**1620**, **1629**, **1660-4**, *etc.*) are to be found on some late medieval jugs in the southern Netherlands (e.g. Hoek 1962-3, 481, *afb.* 18.1, 18.4).

There are also some detailed similarities of technique between the Goldsmith Street kiln wares and those of the Low Countries. The double firing of slipware attested here is unknown in the South-West before the production of North Devon slipware in the 17th century, and the use of a thick slip covering the whole vessel contrasts with the thin brushed lines on local wares of this date. This kind of slip decoration on bowls and dishes is again known in the Low Countries, where sgraffito-decorated examples have been published (Renaud 1959b). The method of attachment of pod feet by pinching the body at the point where the foot is to be affixed, and the thumb impressions at the bases of feet, are precisely paralleled in the kiln at Haarlem (van der Leeuw 1975, 81). The thumb-impressions made on the interior of the vessel (e.g. **1662**, **1667-8**) and the raising of ribs on the body (as in **1660-9**) are also seen there (*ibid.*, 79). The Haarlem kiln is perhaps two centuries earlier than the Exeter products, so the parallel should be treated with some care, but the techniques employed in these two potteries are sufficiently similar to suggest that they belonged to a common tradition.

However, as several Low Countries archaeologists have emphasised to the writer,<sup>1</sup> there are a number of features in the Goldsmith Street assemblage which are foreign to the Low Countries tradition. One is the use of broad strap handles on some of the jugs (**1620**, **1623**, **1639**). Sometimes these handles are knife-slashed, one of them (**1639**) in precisely the manner of South Somerset jugs marketed in large numbers at Exeter in the 16th century (**1805**, **1812**, **1814**, *etc.*). The flat bases, both of these jugs and of the bucket-handled pots and some of the cooking pots (**1666**), contrast with the general use of sagging bases in the Low Countries. The very wide bottoms of **1660-3** are peculiar to the Goldsmith Street kiln. The pipkin handle of **1660** is probably another local feature (cf. **1970-1**, **2172**). Again, at least two of the less common vessel types, the cisterns (**1678-9**) and the cups (**1689-92**), belong to the repertoire of other south-west English potters. Finally, the employment of slate setters to separate pots in the kiln stack was a technique used in other local potteries; slate fragments indicative of this practice can sometimes be seen on North Devon wares of the 16th century (e.g. **1857**).

Why is there this mixture of Low Countries and local styles? One possibility might be that imported Dutch wares were being imitated, and that fashions and eating habits evolved in the Low Countries were being established at Exeter (cf. Brears 1971, 27-31). There are a number of reasons for believing that this explanation is unsatisfactory. Unlike most eastern English ports, the city received very few Dutch redwares which could have served as models for imitation. The range of vessel types displayed in the kiln group is quite anomalous in early 16th-century Exeter. Moreover the similarities of technique and style seem too specific to the writer to be explicable simply in terms of the adoption of foreign fashions, and so few features in this group are local to South-West England that it is more probable that an immigrant potter from the Low Countries worked in Goldsmith Street. Since he served a local market accustomed to very different products, the adoption of a number of local features in his repertoire need occasion no surprise; he seems even to have had a few local pots in his own household (**1698-1704**). There is no clear sign that the style of his wares exerted any influence on local pottery fashions, and his work seems to have been an isolated venture.

#### *Documentary evidence*

Three early 16th-century tax assessments of the city have recently been published (Rowe 1977). These include the Military Survey of 1522, in which aliens were to be listed with their places of birth and their occupations (*ibid.*, ix-xiv). The survey in fact gives occupations only sporadically, but lists places of origin more thoroughly. It reveals a surprisingly large immigrant population. About 80 male aliens are listed, most of them from Holland, Brittany and Normandy, with others from Lombardy and even Lucca. They include servants, shoemakers, hatmakers, a bookbinder, a capper, a skinner and a currier (*ibid.*, 7-33).

The tenement in which the kiln wasters were found lies in the parish of St Paul, Goldsmith Street. In this

parish the following Low Countries immigrants are listed:

Peter Schere born in Holland	worth 40s.
Garret Growning born in Friesland	worth nil
James Selond <sup>2</sup> a Fleming servant	worth nil

(*ibid.*, 13).

In the Subsidy of 1524–5 the entries for St Paul's include Peter Schere, alien, valued at £4, and Nicholas Rutte, alien, valued at £1 (*ibid.*, 37). None of these men is listed in the Subsidy of 1544, nor do they occur in the lists of Exeter Freemen (Rowe and Jackson 1973). Several of the names of immigrants seem to be derived from their places of origin, for example those of Henry Ducheman and John Germyn (*ibid.*, 37). It seems possible that the names Growning and Selond similarly derive from Groningen and Zealand.

It is conceivable that Growning, Selond or Schere was the Goldsmith Street potter; the possibility of a specific connection with Groningen or Zealand is worthy of pursuit in the future. Whether or not the individuals concerned can be identified, these tax assessments demonstrate the presence of a sizeable community of immigrant artisans in the 1520s,<sup>3</sup> and this community provides a milieu in which an immigrant potter may have worked.

#### NOTES

1. I am particularly grateful to T. Hoekstra for drawing attention to those features of the kiln wares which are not known in the Low Countries. It is his belief that these features suggest that the Goldsmith Street potter was not an immigrant from the Low Countries.
2. I am grateful to Mrs S. Reece for further information about individuals with these names, unfortunately unhelpful in this context.
3. There were similar communities at Dartmouth and Totnes (Nicholls 1960, *passim*).

### 6. THE SUGAR-REFINING WARES FROM GOLDSMITH STREET (Fig. 116)

A series of deposits excavated in Goldsmith Street (GS site 1, 77 and 78 and L.13–14) contained over 76 kg of sherds used in sugar refining. The material from each context is identical and so it has been treated as a single group. Associated finds indicate a date of *c.* 1680–1720 (2555–69). The building in which they were found contained none of the distinctive features of a sugar factory so the pottery probably derives from an adjacent but unlocated refinery. No documentary evidence for a sugar-house in this part of Exeter has been found; the only known factory of this period was that at Topsham (Clark 1960, 69–70; Jarvis and Maxfield 1975, 258–9), although the Bishop's Palace in the city had served as a refinery during the 1650s (Oliver 1861, 259).<sup>1</sup>

#### A. FORMS

Despite several hundred hours of labour it has not proved possible to reconstruct any full profiles of these vessels. It is nevertheless evident that three types of vessel used in sugar refining are present. Type 1 is the familiar cone. Types 2 and 3 have not hitherto received discussion, but since they are associated in large numbers with type 1 and are not present in domestic contexts, must surely be connected with sugar refining. Their use for this purpose has been confirmed by the recovery of traces of sucrose in sample sherds (p. 146).

##### *Type 1: Cone-shaped moulds* (Fig. 116, 2570–7)

All vessels of this type have a single hole in the base, tall walls and thickened rims (2570–7 illustrate the range of forms). The fabric is consistently brick-red and of a rather granular texture, without gross inclusions. Variable quantities of fine glittering white particles (?micas) are present. These are vessels of high quality with walls *c.* 4–8 mm thick. All sherds are unglazed and smoothing of the internal surface is commonly visible (e.g. 2572). Of 97 rim sherds, more than half were abraded or chipped on the internal face of the rim; a few showed possible signs of wear around the hole at the base.

##### *Type 2: Globular jars with rolled rims* (Fig. 116, 2580–2).

The characteristic features of these pots are their very thick rims, narrow necks and ringed feet. The reconstruction of 2582 is uncertain, since the base does not certainly belong to the top, but its form is paralleled by complete examples from elsewhere (e.g. 2901 below). The fabric is red and rather sandy with soft red inclusions. Most sherds have orange-red or brown internal glaze with marked iron-bleeding; a few splashes of external glaze were also noted. The rims commonly show signs of wear which has resulted in the removal of a horizontal band of glaze on their interior about 10 mm below the top.

*Type 3: Tall vessels with tripod feet* (Fig. 116, 2583–8).

These vessels have large feet, no holes in their bases, thick walls and plain upright rims. Two types of foot are present: pod feet (36 examples), some with two or three stabbed circular holes to aid firing (2587); and broad flat feet (two examples). One (2586) has two adjoining feet, apparently at right-angles; the base has been reconstructed with four feet, but it may have had three placed unevenly. No. 2587 has three feet. Three-footed vessels are more stable than those with four feet so tripod feet have been assumed in the reconstruction of 2588, which is represented in the collection only by a single foot and adjoining body fragment. The rims are plain and square-topped (2583–5); they show signs of smoothing by hand after throwing, which has distorted the form, making calculations of diameters and minimum numbers difficult. The bodysherds are *c.* 10–18 mm thick, so they are distinguishable from those of types 1 and 2. Over 5,500 such sherds are present, compared with 50 rimsherds and 39 feet. If these figures are representative, the vessels must have had tall bodies. All the bodysherds have gentle curvatures; thus a large, rather globular, conical form is indicated. Among 44 different rims the 35 calculable diameters range from 280 to 480 mm with an average of 340 mm. The fabric is a plain red earthenware similar to that of type 2 but seems very fine-grained. Nearly all the sherds are unglazed, 2586 being exceptional in having a red-brown internal glaze with heavy iron-bleeding; however on the exterior of many sherds there are drips of orange and black glaze, presumably derived from glazed wares fired in the same kiln. Three wall-sherds were pierced, but wet clay had been wiped over two of the holes, blocking them before firing. The third example, which also shows external striations (? from a coarse textile), is illustrated (2585); the purpose of these holes is not known. No sherds were sooted, and no areas of marked wear were noted.

## B. SOURCES

The fabric of types 2 and 3 is much like any post-medieval English red ware. South Somerset may have been the source of type 3: at least one foot similar to those illustrated was found at the Donyatt kiln site (T. Pearson, pers. comm.). The evidence for firing with black-glazed wares would also be consistent with production at Donyatt, as this seems to have been the major source of black-glazed pottery in the South-West. Type 2 shows general similarities of glaze-colour and of fabric with much South Somerset material, but close parallels have not been found. Within each type, vessels look very similar to each other, probably indicating a common source. Type 1 is of a rather different fabric from that of types 2 and 3 and the cones are also more finely potted. The absence of glaze drips on these pots indicates firing with unglazed wares only; perhaps a kiln specialised in their production. It seems likely that they are imports, since they are of higher quality than most of the cones examined by the writer in London,<sup>2</sup> Bristol<sup>3</sup> and Southampton.<sup>4</sup> One possibility is that the cones are of Iberian origin, since their fabric does contain a small amount of white mica;<sup>5</sup> however the sherds are not typical Merida-type wares. They might alternatively have come from London or Holland, since sugar moulds were at this time regularly imported from both these sources. In 1680 300 sugar moulds were imported from Rotterdam; a further 600 sent in 1681 were valued at £7, and 100 'earth sugar moulds' sent from Rotterdam in 1711 were appraised at 50s. (PRO E.190.958/9; 959/8; 984/6). In 1673 '300 moulds for sugar loaves' were sent from London; these may have been re-exports as the cargo also included Flemish bricks and madder (PRO E.190.984/12; 990/15). A Dutch source is an attractive possibility, since the Dutch were leading exponents of all aspects of the art of sugar refining, from the making of the metal boiling pans to the distillation of the residues (Deerr 1950, *passim*; Campbell 1969, 273).

## C. FUNCTION

Summary accounts of the processes of sugar refining are given by Deerr (1950, 2, 458–69) and more briefly by Singer (1956, 372; 1957, 7–8), Gillespie (1959, Pl. 37–42) and Campbell (1969, 272–3). More useful is the remarkably detailed account of the art given by Henri Duhamel de Monceau (1764) from which the summary below is taken.

Sugar arrived in Europe in various stages of refinement.<sup>6</sup> On arrival it was sorted and melted; it was then clarified in large boiling pans, using either egg white or bulls' blood as a clarificant. After skimming and boiling the sugar was transferred to a new room and poured into a 'cooling boiler' from which it was poured into earthenware cones. A small plug was placed over the hole in the bottom of the cone to prevent fluid running out before it crystallised. A crust would form on the top of the sugar and another developed on the sides of the moulds; these were broken by periodic stirring using a long stick. In France both red and white earthenware cones were used. It was important that they should be perfectly conical so that the loaves could easily be removed. Sugar did not stick as much to old pots as to new ones, and so cracked cones were often bound and re-used. With large cones this required binding with thin laths of white wood (2578, front left).<sup>7</sup> Even sherds and broken pots were useful, as they could serve in supporting the cones when they were first

filled with sugar. The cones sat on syrup pots, which had broad bottoms and strongly reinforced rims. The French syrup pots generally had three feet, but these were prone to breakage and some French refiners preferred plain bases. The cones described by Duhamel de Monceau were of graded sizes, with corresponding sizes of syrup pot:

Type of cone	Height of cone in inches	Diameter of cone rim in inches	Height of syrup pot in inches	Capacity of sugar pot
<i>Petit deux</i>	11	5	6	3 <i>chopines</i> (1½ ltrs)
<i>Grand deux</i>	13	6	7	2 <i>pintes</i>
<i>Trois</i>	16	7	8	3 <i>pintes</i>
<i>Quatre</i>	19	8	10	4 <i>pintes</i>
<i>Sept</i>	22	10	12	6 <i>pintes</i>
<i>Bâtarde</i>	30	15	15–18	20 <i>pintes</i>

The largest cones held about 30–35 lb (13.6–16 kg) of sugar, the smallest about 5 lb (2.25 kg). When the sugar had crystallised into a loaf, the cones were taken to an attic (*grenier*) where the plug was removed from the hole and the dark ‘mother liquid’ drained from the cones into the syrup pots. Drainage took about eight days; the liquid was subsequently used in distillation. The sugar loaves were then separated from the cones using a knife, inverted on boards, and examined. Those which were sound were returned to the cones and placed on the syrup pots. Claying then took place; about one inch of liquid pipeclay was poured onto the loaves. This ran through the sugar, displacing the mother liquor still adhering to the crystals. The best French clays for this purpose came from Rouen and Saumur. Claying took about 10 days and was sometimes repeated. When it was finished the cones were inverted and the loaves knocked from their moulds. The loaves were then sent to a drying room, which might hold up to 800 of them. Those which were saleable were wrapped in blue paper which concealed any yellow tint in the sugar.

Whilst there were no doubt many differences in local practice, this account is illuminating in many respects. The signs of heavy wear visible on the top edges of the Exeter cones is attributable to the removal of the loaf with a knife after drainage and claying. The sizes of cones from Exeter can be compared with those given by Duhamel de Monceau:

Rim diameter of Exeter cones (mm)	Min. No. of vessels (Exeter)	French sizes	Rim diameter recorded by Duhamel de Monceau (mm)
140	3	<i>petit deux</i>	130
150	2		
160	8	<i>grand deux</i>	150
170	9		
180	14	<i>trois</i>	180
190	8		
200	6	<i>quatre</i>	200
220	3		
240	6	<i>sept</i>	250
260	1		
		<i>bâtarde</i>	380
Not calculable	25		

It will be seen that the Exeter vessels are similar in size to the French examples but lack the largest form. There is however no evidence of a series of precisely graded sizes at Exeter.

Type 2 is clearly the syrup pot, without the optional feet. Further examples are present at Southampton (Platt and Coleman-Smith 1975, 2, No. 840) and there are numerous examples in the Museum of London, some from known sugar houses (e.g. Museum of London Acc. No. 27–70/1, ‘from the site of an old sugar factory in Thames Street’).

Type 3 presents more difficulties as it is not described by Duhamel de Monceau. An illustration in Diderot’s Encyclopedia suggests a possible function for the type (Gillespie 1959, Pl. 39). In this case the sugar was poured after boiling into large earthenware vessels in which granulation began. This seems to be a variation on the practice described by Duhamel de Monceau. The illustration (re-drawn here, 2579) shows the stirring of sugar adhering to the sides of these pots. Granulation was then completed in shallow wooden tanks. It

seems probable that type 3 served the function of these pots; the feet of the Exeter examples would obviate the need for the external supports shown in the illustration.

#### D. ECONOMIC CONTEXT

The factory's suggested period of production of *c.* 1680–1720 corresponds with that of the documented house at Topsham, where production had probably begun by 1684 and ceased at a date between 1736 and 1743 (Jarvis and Maxfield 1975, 158). The economic circumstances which brought about the prosperity of these two factories have been examined by Clark (1960, 130–1) and Hoskins (1935, 89–90). In the 1680s Exeter ranked below only Bristol and Liverpool in the Plantations trade. Re-export of sugar after its refinement in England was a major aspect of the trade, and in the period 1680–1735 substantial shipments of locally refined sugar were made to Rotterdam, Gothenburg, Bremen, Ostend and Gibraltar. Despite Exeter's favourable position, its share in the trade waned after *c.* 1720 (*ibid.*) and had ceased by *c.* 1740.

The refinery deposit is thus an archaeological reflection of Exeter's Atlantic trade. The years *c.* 1690–1720 similarly saw a boom in the city's clay pipe manufacture (Arnold and Allan 1980), and it is no coincidence that the two substantial deposits of pipe-making debris from the city are of this date. The opportunities afforded by the Atlantic export trade may also explain the rise at this period of glass manufacturing at Topsham (Clark 1960, 69–70). The failure of these small industries in the second quarter of the 18th century was symptomatic of Exeter's decline as a major centre of manufacture and international trade at this period.

#### NOTES

1. The palace was leased to a sugar baker between *c.* 1650 and 1662. Troughs and other features of the refinery were exposed during alterations to the palace in 1821 (Oliver 1861, 259).
2. Unpublished finds from various sites, in the Museum of London.
3. Unpublished finds from various sites, in Bristol City Museum.
4. Finds from the sugar house published by Platt and Coleman-Smith (1975, 2, Nos. 883, 840) and from unpublished excavations by R. G. Thomson; however the latter also seem to be high-quality imported vessels.
5. Thin-sectioning by David Williams confirmed the presence of white mica and showed that an Iberian source is a possibility.
6. The Exeter Port Books give some idea of the varieties available locally: muscovado, brown sugar, brown sugar fit for use, and white sugar fit for use were all imported. Much of Exeter's sugar came from Barbados, which was sending cargoes as early as 1666. Other sources were the American Colonies, Santa Domingo, Antigua and Portugal.
7. Illustration re-drawn from Gillespie 1959, Fig. 41.

### 7. THE SALE OF POTTERY IN EXETER AND ITS REDISTRIBUTION

#### A. THE LOCAL MARKET

Evidence regarding the sale and redistribution of ceramics in the city has, not surprisingly, proved rather sparse, but enough has been found to show that there was a variety of possible means of distribution.

First, the sale of ceramics in street markets must have been common. In the 15th century a description of the tolls levied by the Dean and Chapter on merchandises sold in the cathedral cemetery and king's highway includes 'disshes bollys and other thingges lyke' (Moore 1871, 93). In the late 16th century Hooker records a long list of payments to be made when selling in the open markets of the city. They included:

Cups of stone uncovered	the dozen	1d.
Cups of stone covered	the dozen	1d.
Bottles of stone covered with wicker	the dozen	½d.
Earthen pots	the 100	1d.
Brick and Flanders tile	the 1000	1d.

(Harte *et al.* 1919–47, III, 553–6).

The position of an earthenware market at this time has not been located. By the early 19th century, the stands were at the top of High Street, between East Gate and King's Alley: here were sold earthenware, stoneware, glass and china (Cossins 1877, 13). Similarly at Crediton the 'cloam shambles' had an allotted space in the centre of the Fore Street, as a recently discovered map of the 1730s or early 1740s shows (DRO 2065 Add.).

Sale at fairs presented a second outlet. A schedule of 1583 lists duties to be paid by foreign merchants at fairs in the Merchants' Hall in High Street (AB IV, 414–17); on the sale of every maund of cups (probably stoneware) they were to pay 6d. In the 1650s, Thomas and Richard Ford brought goods from Holland specifically for sale at the city fairs (Stephens 1958, 142–3). Stonewares were often present amongst their goods: the Fords had been importing them since the 1630s (PRO E.190.950/7). Fairs also presented an opportunity for the sale of local earthenwares at Exeter. Somerset 'badgers' were licensed by their local J.P.s



to take local produce to Exeter and return with imported wares (Stephens 1958, 143). None of the licences examined referred to the transport of earthenwares, but it seems probable that such men provided a means both for the carrying of South Somerset pottery to Exeter and for the distribution of imports into Somerset.

Third, ceramics were sold in a variety of shops. Perhaps the best documented example at Exeter is that of Thomas Macumber, an ironmonger (Rowe and Jackson 1973, 125, 127). On his death in 1622 he left both a warehouse and shop full of a remarkable range of metal goods, glassware, brushes, wax, paper and miscellaneous goods including the following items of pottery:

<i>In the shop</i>	
17 doz stone pots	£2 5s. 6d.
<i>In the warehouse</i>	
14 doz 2 stone potts with salts & Clome [i.e. earthenware] potts covered and uncovered	£1 15s. 0d.
16 Smale Clome Pipkings & Cups	0 1s. 0d.
9 doz of gally Potts att	0 13s. 6d.

(OC 139).

There were also '21 smale Flemish dishes' valued at 3s., which may well have been of pottery. A total of 374 stonewares and 108 tin-glazed wares are listed; compared with these, the quantity of local earthenware is small. Macumber left debts of over £1000, many of them to local chandlers and grocers who were presumably supplying him with goods. His largest individual debt was to George Jurdain, to whom he owed £199. Jurdain's name recurs in the Exeter Coastal Port Books of the early 17th century. He was a major importer of household goods from London, including stonewares and mixed loads of pottery and glasses (e.g. PRO E.190.945/5). It seems probable that Macumber was buying his ceramics from Jurdain.

Ceramics were also listed in the shops of men of other Exeter professions. Apothecaries stocked large quantities of tin-glazed wares. As early as 1596, Thomas Baskerville had the following items in his shop:

2 dossen of syrup pottes with pipes	12s. 0d.
16 oyl potts with pipes	5s. 4d.
18 dossen & halfe of other gally potts	55s. 6d.

(Rowe and Trease 1970, 20).

This inventory, with over 250 tin-glazed pots listed, provides the earliest evidence found so far of the extensive use of delftwares in Exeter. Two further apothecaries had ceramics in their shops. In 1622 Walter Kelland had the following items:

10 syrup potts	5s.
13 oil potts	4s.
Divers other potts little and great	10s.
13 Stone jugs	1s. 1d.

(OC not numbered).

In 1661 the goods of Charles Everleigh, apothecary, included:

20 Spout potts	10s.
12 Blew Gallipotts	5s.
8 Syrup Pots	3s. 4d.
13 Electuary Pots	1s. 2d.
12 Conk. Pots	2s.
24 Ointment Pots	2s.
28 Oyle Jugs	2s. 8d.
10 Pill Pots	2s. 6d.
16 Bottle Stone Jugs	4s.

(OC 139).

It is notable that none of these three was selling delftware dishes, and presumably their pots were either for professional use or were sold with the items they contained.

One chandler appears to have sold pottery: in 1626 Robert Beale left cups and jugs in his shop valued at £2 10s. (OC 158). Evidence of the interest of chandlers in pottery is not confined to Exeter; Dyer found several parallel cases in Worcester (Dyer 1973, 131). Finally, in 1594 an Exeter vintner, John Spurway, had four dozen cups valued at 4s. in his shop, a further maund of cups valued at 30s. in a chamber over his cellar and two half maunds also valued at 30s. in his forechamber (OC 57). The valuations of the first items are low, so they may well have been earthenwares or stonewares; perhaps they were sold to inns and private customers alongside his wines.

No evidence has been found for the existence in the 16th and 17th centuries of specialised earthenware shops. The earliest example noted by the writer dates to the 1730s, when widow Southey's earthenware shop stood at the corner of Palace Gate and South Street (Curtis 1932, 89). By the time of Exeter's first directories

at the end of the 18th century, such shops had become common. They seem often to have concentrated on the sale of high-quality wares from Bristol and Staffordshire (Douch 1969, 34–5) and their rise is paralleled by the growth of china shops in London (Toppin 1935, 48–53).

## B. THE SEAWARD REDISTRIBUTION OF CERAMICS

Although Exeter had little direct contact with the Low Countries in the 16th and early 17th centuries, it functioned as a redistributor of Rhenish and Dutch ceramics to the other ports of the South-West. About 10% of the Elizabethan stoneware cargoes imported here was subsequently re-exported to the ports of Devon and Cornwall (Fig. 62). This trade was most commonly conducted by the merchants of the recipient ports, who presumably purchased parts of the large stoneware cargoes which Exeter merchants had brought to the city. Further small shipments were made throughout the 17th and early 18th centuries but lack of detail in the Coastal Port Books precludes any assessment of their precise volume (details in MF 54).

In addition, Exeter occasionally re-exported ceramics to Ireland. In the late 16th and early 17th centuries Irish ships quite often returned to Youghal and Wexford with Low Countries hardware bought at Exeter such as frying pans and dripping pans, but no stoneware cargoes are listed among these goods. The trade continued throughout the late 17th and early 18th centuries, and in 1680 and 1698 the city Port Books record the export of single shipments of stoneware to Youghal, the latter of 200 cast (PRO E.190.958/8; 972/18). Since it was cheaper first to carry goods overland to Barnstaple and Bideford rather than to ship them by sea (Hoskins 1935), imported ceramics were also transported to the North Devon ports for sale in Ireland. In 1693, for example, an entry in the Port Book of Bideford and Barnstaple records the re-export to Ireland of 12 cups of earthenware, carried overland by Philip Bastard, who had paid duty inward at Exeter a fortnight earlier (PRO E.190.968/7).<sup>1</sup> Bastard had brought the cups from Rotterdam.

More important, there arose a trade supplying the American Colonies with Dutch and Rhenish ceramics. The city must have been one of several ports involved in this trade: certainly neighbouring Dartmouth also participated. In 1699, for example, 618 cast of pots and mugs imported from Rotterdam were re-exported from Dartmouth to Barbados and 1003 cast of stonewares were sent from there to Carolina (PRO E.190.975/3). At Exeter this trade had begun by the 1680s, when many Flemish drinking glasses were sent from the city. Thus in 1682, 1450 were sent to Barbados and another 300 to New England (PRO E.190.960/7). The trade in these glasses collapsed in the 1690s, but the resumption of stoneware and earthenware shipments at that time opened up a new redistribution trade. A total of about 400 cast of stone bottles, cups and jugs, together with earthenware valued at 15s., were sent to Virginia in 1690, 1697 and 1698; earthenwares were sent to New England in 1699 and 300 cast of stonewares to Newfoundland in 1706 (PRO E.190.966/8; 971/44; 972/18; 975/3; 979/1). After c. 1710 that trade grew markedly (details listed in MF 55–7).

It appears that some of the particularly high levels of stoneware imports into Exeter in c. 1710–20 resulted from the rise in the city's re-export trade rather than from increased consumption at Exeter or in Devon. The increased quantity of earthenware exports after 1710 is particularly notable, since their import into Exeter was by then falling rapidly (Fig. 58). In the decade 1710–20, Barbados was much the most important recipient of these goods, taking annually an average of about 430 cast of stone pots, 130 stone bottles, and earthenware valued rather less than £8. Barbados also had a particular demand for pantiles, which had been shipped there as early as 1683, and 56,000 of these were sent in five years between 1712 and 1722. The island provided a market for about 95% of all pantiles shipped from Exeter. After 1722, however, no further Port Books refer to re-exports to Barbados, and the trade seems to have ceased, perhaps reflecting the collapse of Exeter's interests in sugar. Of the other colonies, New England, Virginia and Carolina were the most important markets (MF 55–7). The trade probably decayed after the 1730s, reflecting the declining fortunes of the city's Atlantic trade (Hoskins 1935, 90–1).

Upon their arrival at Topsham, ceramics designated for re-export seem to have been placed in the King's Cellar on Topsham quay: on several occasions they paid duty whilst in this cellar. Many months often elapsed before they were re-exported and delays of about a year were not uncommon. When, for example, Daniel Ewings sent a cargo of stoneware to Carolina in January 1752, it comprised three different batches of imports, one of which had paid duty inwards at Exeter as early as February 1748 (PRO E.190.1004/2).

It is apparent from the Port Books that several merchants specialised in the provisioning of ships for the colonies. Amongst these, Roger Prowse is perhaps the most prominent figure. His name recurs in the Port Books of the years 1710–22; he repeatedly shipped large batches of household goods including linen, pewter goods, Purbeck marble and Devon roof slates to Barbados, and these cargoes often included Dutch and Rhenish ceramics. For example, in 1722 one ship carried 30,000 pantiles, 200 stone jugs and 300 cast uncovered stone pots (PRO E.190.995/6). He regularly used the ship the *Land of Promise* for this purpose; it would sometimes travel to Rotterdam, then call in at Exeter on its way to Barbados. More commonly the Dutch goods were shipped by Prowse in other vessels from Rotterdam to Exeter, evidently with the specific

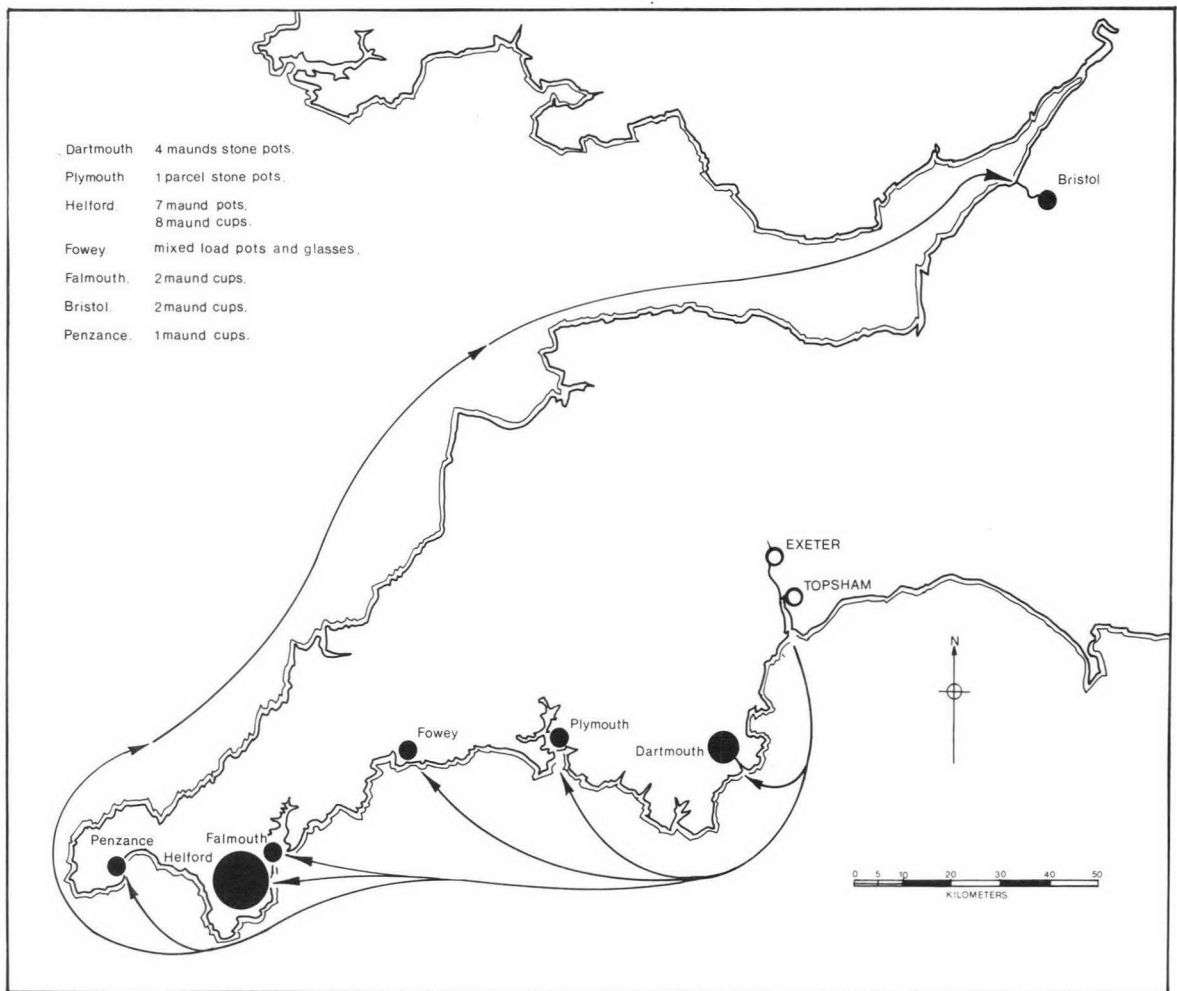

Fig. 62. The coastal redistribution of stonewares from Exeter, 1565–1600 (source: PRO E.190. Coastal Port Books).

intention of re-exporting them; within a few days they were re-loaded onto the *Land of Promise*. Prowse was also involved in the trade with other colonies: for example in 1711 he placed a large cargo of ceramics on the *Reserve* for New England. This comprised earthenware valued at £17 15s., 50 cases of bottles valued at £12, 1545 cast of uncovered stoneware pots, 50 dozen stoneware bottles, and 1,000 feet of galley tiles (PRO E.190.984/6). Prowse had brought these goods from Rotterdam to Exeter in two ships, the *Reformation* and the *Hannah*; they had paid import duty earlier that day. The cargoes to New England and Virginia included large quantities of English and imported cloth, English pewter and ironmongery, felt hats, shoes and a variety of miscellaneous items, sometimes including Purbeck marble and Devon slate. The names of Thomas Toosloe, Ann Lee and Ann Eliot, the merchants who specialised in the importation of stoneware, rarely occur among the lists of re-exporting merchants, and most of their wares must have been sold in the South-West.

Amongst many thousands of entries in the Port Books, no evidence was found of the re-export of Dutch or Rhenish ceramics to Spain, Portugal or France. When one contrasts the pattern of ceramics redistribution with, for example, that in Exeter tobacco-pipes (Arnold and Allan 1980) it is apparent that the re-export of Rhenish ceramics provided goods for a very limited market. The clay pipes travelled to most of the ports trading with the city in Scandinavia, Brittany, Spain and Portugal, and had an important market in Newfoundland. By contrast, stonewares and Dutch earthenware went principally to Barbados, which did not feature at all in the clay pipe trade. These differences show the dangers in drawing conclusions about trading links from the distributions of single classes of artefact.

Finally, there is a scatter of late 17th- and early 18th-century references to the export of English pottery, principally to the American colonies but also to Portugal, Italy and Madeira (details in MF 59). Some of the 17th-century shipments were English tin-glazed wares: for example 300 gallipots were sent to Virginia in the 1680s and 100 to Barbados in 1678 (PRO E.190.957/3). However, the majority of shipments were recorded in parcels and dozens, the units normally used in assessing coarsewares, and these were presumably local south-western products. Virginia and New England were the most popular destinations between 1680 and 1720; Maryland and Carolina took the largest consignments of the years between 1720 and 1750. This trade was always a small one: the total exports from Exeter rarely averaged more than a hundred parcels per year,

far fewer than those of the major export trade from North Devon. These references do suggest however that small quantities of South Somerset pottery, the wares most commonly used at Exeter, may be found on Colonial American sites.

#### NOTE

1. I am grateful to Dr A. Grant for drawing my attention to the entry in the Port Book of Bideford and Barnstaple.

## 8. PETROLOGICAL AND CHEMICAL ANALYSES

### A. THE PETROLOGY OF THE OLIVE JARS AND MERIDA-TYPE WARES

by D.F. Williams

#### *Olive jars*

Five samples were examined, one (**1463**) from a 15th-century group, the remainder from the late 16th-century contexts GS L.16–18 and GS L.24. The former sherd appears in a fairly hard, rough sandy fabric, with small limestone inclusions, pinkish-white (7.5YR 8/2) throughout. The other four sherds are all in a hard, rough sandy fabric, again with small limestone inclusions apparent, generally with a white slip on the outer surface and reddish-yellow (5YR 7/6) inner surface and core. Thin-sectioning reveals that all the samples contain a similar range of inclusions, the main features of which are fragments of quartz-mica schist, sandstone, quartzite and limestone, together with discrete grains of quartz, plagioclase and potash feldspar and flecks of mica, set in a fairly clean clay matrix. The 15th-century example **1463** appears slightly finer-grained than the other sherds.

It is normally considered that the earlier forms of medieval and post-medieval 'olive jars' were generally made in Andalusia, more particularly near to Seville or Cadiz (Goggin 1960, 5). The petrology of the Exeter sherds would seem to confirm this, for there are many points of similarity in fabric between this material and the Roman amphora type Dressel 20, known to have been made in the region of the River Guadalquivir between Seville and Cordoba (Peacock 1979).

The Exeter sherds were compared with Spanish 'olive jars' from Southampton dated to the 14th and 17th centuries, and agreed well in thin-section (pers. comm. Roberta Tomber). This clearly demonstrates similarities in fabric of these vessels over a long period of time, and strongly suggests that they share a common area of origin.

#### *Merida-type wares*

A group of 15 red micaceous vessels, mainly from 16th-century contexts, was studied macroscopically with the aid of a binocular microscope (x20). The majority were thin-sectioned and examined under the petrological microscope as part of a current programme of petrological analysis of 'Merida-type' imports to Britain. Broadly speaking, the sherds from Exeter appear to fall into two main fabric groupings. Fabric 1 is represented by six samples ranging in date from the early 16th century to c. 1700. This is fairly micaceous (both muscovite and biotite are present), and contains frequent grains of quartz. Fabric 2, represented by nine samples dating from c. 1500 to the late 16th century, is slightly finer-textured with less mica and a scatter of larger quartz grains, together with some plagioclase, microcline, orthoclase and perthite feldspars, and a little quartzite, sandstone and siltstone.

The sherds from Exeter are not unlike certain 'Merida-type' vessels found at Stonar, Plymouth Castle, Southampton and Guy's Hospital, London. There are, however, a number of clear fabric differences amongst the latter material, together with differences among samples of medieval Iberian red micaceous pottery, to indicate that this particular type of ware was not made at a single centre but was more probably produced at a variety of places in both Spain and Portugal (Williams 1979). It may be worthwhile noting that there are similarities in fabric between Exeter fabric 2 and the red micaceous pottery recovered from two wrecks of the Spanish Armada, the *Trinidad Valencera* and the *Santa Maria de la Rosa* (*ibid.*). On documentary evidence a source for the red micaceous Armada pottery in or around the Lisbon area seems likely (Martin 1979), and a similar origin for some of the Exeter vessels is therefore a possibility. However, more work needs to be done before their origins can be distinguished with greater confidence.

DOE Ceramic Petrology Project,  
University of Southampton,  
April 1982.

## B. A NOTE ON THE PETROLOGY OF THE SPANISH AND PORTUGUESE TIN-GLAZED WARES

by Alan G. Vince

All the Iberian tin-glazed wares from Exeter were examined under x20 binocular microscope. The three vessels of 13th/14th-century date (including **113**, **1196**) contain the distinctive metamorphic rock fragments of Andalusian wares. A single dish sherd from an early 16th-century pit (PS 402) contains the same inclusions, and comes from the same area, even though it has the pink fabric with buff margins which is supposedly typical of Valencian pieces. By contrast, the three dishes decorated in *cuerda seca* technique (including **1821** and **2741**) contain the black and white mica fragments which occur in the products of South-East Spain, and this strengthens the case for believing that they come from the area of Seville. One further vessel (**1785**) contained the same inclusions.

The 17th-century dishes which are possibly of Portuguese origin are divisible into two groups, one of them tempered with coarse sand (including **2753**), the other much finer in texture. None of the other sherds could be characterised petrologically.

Museum of London,  
January 1982.

## C. POST-MEDIEVAL FOOD RESIDUES FROM EXETER

by J. Evans and S.M. Elbeih

Very few post-medieval sherds with adhering internal residues have been noted in the Exeter collection. One with a black/brown residue (Sample 1) was examined; four other sherds without visible residues were also tested. These samples were subjected to the same analytical procedure as the medieval sherds with food residues (pp. 37-8).

*Sample 1:* sherd from base of **2352**. Analysis of this residue identified the presence of alanine, proline and valine (amino acids); starch, glucose, fructose and maltose (carbohydrates), and relatively high levels (c. 3% total) of tartaric, citric and fumaric acids (polybasic acids). Trace amounts of other amino acids and carbohydrates were detected but not identified. The inorganic part of the residue consisted mainly of calcium and magnesium carbonate with traces of iron and copper. The inorganic substances clearly indicate that the system originally contained in the vessel was an aqueous one. The polybasic acids are usually associated with wine or similar fermented material. The carbohydrates present would argue in favour of beer as opposed to wine. The combination of amino acids gives further support for a beer system as a similar range of acids has been isolated in beers. It seems reasonable to conclude that this vessel had, at some time, been used for beer or, less likely, wine or both.

*Samples 2 and 3:* bodysherds from sugar cone (as **2570-7**) and tripod vessel (as **2583-8**). Very low levels of sucrose were detected in these. No other organic material was found. It would seem that both specimens were, indeed, concerned with sugar.

*Sample 4:* bodysherd from Martincamp flask **1747**. Traces of glycerides were detected which might have been olive oil, but levels were such that no firm conclusions could be drawn. No other organic materials were detected.

*Sample 5:* basal sherd from Cornish jug **2178**. Traces of amino acids were found. Alanine and tartaric acid were identified but levels of other compounds were too low for characterisation. One can tentatively infer that the jug had been used for beer or a similar system.

*Sample 6:* unglazed Saintonge jug **1748**. Extraction of the sherd gave triglycerides, proteins and possibly traces of haemoglobin. Unfortunately the presence of this latter material could not be confirmed. Saponification of the triglyceride extract showed it to consist of stearic and palmitic acids with very low levels of oleic acid. Such a combination of acids suggests an animal origin for the material.

Hydrolysis of the proteins gave a wide range of amino acids including glutamic, glycine, leucine, lysine and both proline and hydroxy-proline. Such a combination suggests a meat origin for the protein. It would seem that the jug had contained a meat

system of some sort, possibly a gravy.

*Sample 7:* Coarse Sandy ware bowl **1776**. This sherd gave a protein fraction only. On hydrolysis the amino acids glycine (61%), proline (24%), hydroxy-proline (2%) and alanine (11%) were identified. The aqueous extract also contained calcium phosphate and traces of sodium chloride (common salt). It would seem, therefore, that the pot contained gelatin. It may well have been a glue pot.

*Sample 8:* Spanish olive jar **2129**. Only triglycerides were detected in this pot sherd. On saponification the material showed the characteristics of olive oil which was approximately 10% hydrogenated (probably resulting from burial of the sherd). Clearly the vessel was used for storage/transport of olive oil. The absence of other organic fractions such as proteins, carbohydrates, etc. shows that the vessel had no secondary usage.

*Sample 9:* English ?chamber pot **2138**. No organic material was extracted from this sherd. The aqueous extract, however, gave a very positive phosphate test and was found to contain calcium phosphate. Low levels of sodium and chloride were also found. The murexide test (for uric acid) gave negative results. As this latter test is not very sensitive under archaeological residue conditions its failure is not necessarily significant. The pot therefore may well have been a chamber pot.

*Sample 10:* South Somerset cooking pot **2142**. Analysis of this sherd identified the presence of glycine, proline and alanine (amino acids); starch and glucose (carbohydrates) and traces of some complex phenolic compound, possibly tannic acid. No polybasic acids were detected. As the levels of all extracts were very low it is not possible to draw firm conclusions. The presence of starch (and its decomposition product glucose) would suggest either a gruel or stew of some description. The phenolic compound (suspected tannic acid), is intriguing, but probably derives from the many leather shoes in this deposit.

*Sample 11:* Coarse Sandy ware jar **2165**. Very low levels of palmitic and stearic acid were detected in this pot accompanied by trace levels of protein. At first sight the vessel would seem to have been used in a similar manner to **1748**. However the very low levels of organic residues suggest very thorough cleansing probably after excavation and consequently the levels of carbohydrates, etc. may well be too low to be detected.

North-East London Polytechnic,  
January 1982.

## 9. THE CATALOGUE

## A. THE TYPES OF POST-MEDIEVAL POTTERY

<i>Chinese porcelain</i>	Illustration Nos.	North Holland slipwares	2034, 2067, 2368, 2516-17, 2629, 2761-3
Wan Li, c. 1590-1620	1984-5, 2100-1, 2269, 2272-7	Low Countries sgraffito-decorated slipwares	1983, 2093
Blue-painted, c. 1685-1725	2513-14, 2589-90, 2915	White wares	?2189, 2557
Blue-painted, c. 1720-70	2686-9, 2691, 2700-1, 2921-30	South Netherlands maiolica	1540, ?1548, 1549, 1842, 1962, 2754-8
'Chinese Imari', c. 1750-70	2916-18		
<i>Famille rose</i> , c. 1750-70	2702, 2919		
'Steatitic' porcelain, c. 1750-70	2920		
		<i>German earthenwares</i>	
?Mediterranean		Weser slipware	2760
Green-glazed red wares	1840, 1939-41	Cologne encrusted wares	2082, 2759
		<i>Stonewares</i>	
<i>Italian</i>		Langerwehe	1708, 1736
Florentine tin-glaze, 15th-century	2725	Raeren mugs	1539, 1696-7, 1705-7, 1730-5, 1791-4, 1820, 1825, 1830 (Raeren or Aachen), 1835-6, 1839, 1853, 2779
Tuscan maiolica, 16th-century	1862	Late 16th-century Raeren globular jugs	1851, ?1964
Ligurian or Venetian tin-glaze, 16th-century	2730	Late 16th-century Raeren decorated jugs	2041, 2784
Ligurian tin-glaze, 17th-century	2270, 2515	Cologne, oak leaves, acorns, rosettes	1737-41, 1788-9, 1831
Marbled wares	2448, 2461, 2733-4	Cologne, plain early 16th-century jugs	1709, 1742-5
Montelupo	1986, 2064, 2102, 2726-9, 2731	?Cologne, tall tankard	1891
Oil jar	2902	Cologne-Frechen inscribed bands, acanthus leaves	1863, 1890, 1937-8, 1950, ?2780-1, 2783
?Italian, tin-glaze	2732	Plain Frechen	1850, 1852, 1870, 1881, 1892-5, 1932, 1934, 1951-3, 1978, 1980, 1989-91, ?2042, 2053, ?2122, 2123-7, 2175, 2187, 2317, 2362-3, 2446-7, ?2518, ?2541, 2931-2, 2312-16, 2361, 2394-5, 2434, 2441, 2497, 2519, 2555, 2642, 2655, 2785-95, ?2796, 2801
		Siegburg	1729, 2782
<i>Spanish</i>		Westerwald, early 17th-century decorated jugs	1988, 2032-3, 2080, 2121, 2445, 2798-2800
Olive jars	1849, 1885, 1930, 2060, 2129-30, 2182, 2390, 2495, 2744-5	Westerwald, later jugs	2320-3, 2391-3, 2520-2, 2542-3, 2599, 2640-1, 2656, 2803-5
Valencian tin-glaze	1533-4, 1547, 1713, 1785, 1841, 1879, 1883, 2179, 2735-7	Westerwald, tankards	2318-19, 2496, 2510, 2556, 2597-8, 2705, 2802, 2806-10
Isabela polychrome	2739	Westerwald, chamber pots	2672
Yayal blue-on-white	2742	Westerwald, other form	2811
<i>Cuerda seca</i>	1821, 2741		
Columbia plain	?1535	<i>Delftware</i>	
Lustreware, 16th/17th-century	2738	Malling jugs	?1933, 1968
Lead-glazed	2743	Dutch, early 17th-century	?1987, ?2059, 2105-14, ?2116, 2183, 2185, ?2287, 2432-3, 2474, 2476, 2812-22
Unclass. Spanish tin-glaze	2180-1, 2740	Dutch, late 17th-century	2271, ?2278, 2279-81, 2283-4, 2286, 2431, 2504, 2650, 2824-5, 2830-4
		Dutch, early 18th-century	2450-1, ?2462, 2498, ?2653, 2654, 2826-9
<i>Portuguese</i>		English, late 17th-century	2103, 2118-20, ?2285, 2292, ?2297-2311, 2387-8, 2435, 2475, 2505, 2835, 2839-40, 2845
Merida-type	1531-2, 1790, 1832, 1838, 1884, 1886, 1921, 2746-51	English, 18th-century	2544-8, 2559, 2591-5, 2628, 2638, 2651, 2673, 2690, 2696-7, 2703-4, 2836-8, 2841-4, 2846-8
Tin-glazed, 17th-century, ?Lisbon	?2104, 2117, 2174, 2282, ?2752-3	Delftware of uncertain origin	2039-40, 2065, 2115, 2184, 2186, 2288-91, 2293-6, 2360, 2389, 2490, 2560, 2639, 2652, 2823, 2849
		19th-century delftware	2850 (?north French), 2852
<i>South-West French</i>		<i>English wares</i>	
Green-and-brown	2776	Surrey-Hampshire white wares	1935, 1992-4, 2044, 2081, 2133-5, 2188, 2331, 2369-70, ?2396-7, 2477, 2491, ?2561-2, 2909-12
<i>Saintonge</i>		Bristol-Staffordshire yel-	2442, 2489, 2506-7, 2596, 2600,
Unglazed jugs	1748, 1784, 2176		
Chafing dishes	1746, 2043, 2128, 2771, 2772		
Marbled wares	2364-5, 2367, 2775		
Late polychrome wares	2773-4		
Other	2913		
<i>North French</i>			
Martincamp type I	1747, 1880, 1889		
Martincamp type II	1829		
Normandy stoneware	2494		
Beauvais drinking jugs	1786-7, 1822, 1826, 1837, 2767		
Beauvais sgraffito	1887-8, 2764-6		
Beauvais combed earthenware	1536, 1923		
Beauvais stonewares	1537-8, 1710, 1931, 2768-70		
?French			
Green-glazed white wares	1845, 1963, ?2397, 2777-8		
<i>Tudor Green</i>	2081, 2396		
<i>Low Countries earthenwares</i>			
Redwares	2449, ?2549, 2558, 2630		

low slipwares	2677-8, 2692-5, 2906-8	1956, 1958-9, 1965-7, 1969, 1981, 2142-6, 2872-8
Bristol-Staffordshire treacle-brown glazed wares	2511, 2550-1, 2603-5, 2905	1999-2012, 2035-8, 2046-8, 2054-7, 2061-3, 2068-79, 2085-99, 2147-55, 2177, 2197-2268, 2332-56, 2378-85, 2410-20, 2424-6, 2428-9, 2438-40, 2444, 2456-60, 2880, 2893
Bristol-Staffordshire press-moulded dishes	2512, 2632-3, 2660, 2710	South Somerset 17th-century wares
Bristol-Staffordshire grey stonewares	2601-2, 2634, 2698-9	
Staffordshire white salt-glazed stoneware	2643-5, 2658-9, 2674-6, 2706-8	South Somerset 18th-century wares
Staffordshire earthenware	2709	
Nottingham stoneware	2657	
North Devon slipwares	2190, 2324-7, 2330, 2371, 2374-7, 2398-2401, 2452-5, 2523-6, 2552, 2661, 2853-64	Coarse Sandy wares
North Devon coarsewares	1543, 1557-8, 1857, 1897-1902, 1924, 1945-6, 1955, 1957, 1995-8, 2045, 2083-4, 2136, 2138-40, 2158, 2163, 2191, 2193-6, 2329, 2372-3, 2402-9, 2422-3, 2427, 2430, 2436-7, 2443, 2464-6, 2479-82, 2508, 2527-8, 2553, 2565, 2606-7, 2648-9, 2662-8, 2865-71	
North Devon white wares	2192, 2328	Micaceous wares
South Somerset 15th/16th-century wares	1541-2, 1545, 1550, 1554-5, 1698-9, 1701-3, 1711, 1714, 1752-74, ?1783, 1797-1805, ?1806, 1811-14, 1816, 1818, 1827-8, 1833, 1843-4, 1847-8, 1854-6, 1866-8, 1871-8, 1905-12, ?1926, 1927, 1944, ?1947-8,	Goldsmith Street wares
		1700, 1704, 1725-8, 1775-81, 1807-9, 1815, 1817, 1824, 1846, 1858-61, 1869, 1913-14, 1928-9, 1960, 1970-7, 1979, 2013-31, 2049-52, 2058, 2066, 2156-7, 2159-62, 2164-8, ?2348, 2898
		1717, 1750, 1795, 1810, 1834, 1864-5, 1896, 1903-4, 1942-3, 1946, 1982, 2137, 2178, 2463, 2554
		1620-95, ?1712, 1718, ?1719-21, 1782
		<i>Tiles</i>
		Spanish 2933-4
		Dutch lead-glazed 1882, 2173
		Dutch tin-glazed 2357-8, 2935-43
		North Devon 2866

## B. FABRIC DESCRIPTIONS

The following wares recur throughout the catalogue and will not be described in detail or referenced each time they are listed:

### Italian (Blake 1981)

- Montelupo tin-glaze: Fine buff or pink fabric with minute red inclusions. Thick tin glaze both *int* and *ext*. Brightly painted colours.
- Marbled: Fine hard red fabric sometimes with white inclusions or fine vesicles (Hurst 1967).

### Iberian

- Olive jar: Coarse granular fabric with much rounded quartz filler and occasional mica plates. Often coated with *ext* slip or with *int* glaze (Goggin 1960).

### French

- Saintonge: Fine white or pink fabric, sometimes with fine white mica inclusions (Hurst 1974b).
- Martincamp type I: Hard buff-pink earthenware without glaze or gross inclusions (*idem* 1966; *idem* 1977d).
- Martincamp type II: Light or dark grey stoneware, sometimes with patches of light grey or light brown glaze. Surfaces are commonly rather battered (*ibid.*).
- Normandy stoneware: Dark brown or purple-brown fabric with black margins and mauve-brown to black surfaces (Barton 1977b).
- Beauvais earthenware: Very fine white fabric (Chami 1963). Green-glazed jugs from Exeter have a very rich glossy mid green glaze. Yellow-glazed examples often have flecks of black iron-bleeding (Hurst 1971b).
- Beauvais stoneware: Light cream or fawn stoneware, often with light grey surfaces, sometimes with patches of light grey or brown glaze.

### Low Countries and German earthenwares

- Low Countries redware: Granular, rather dense, red fabric, clear lead glaze with very little iron-bleeding.
- North Holland slipware: Fabric as above, with thick trailed slip decoration, often with copper-green in slip (Hurst *et al.* 1975).

### Low Countries and German stonewares

- Langerwehe: Very dark grey stoneware, often with an iron wash giving a dark brown glaze. Often has very prominent throwing grooves (Hurst 1977b).
- Raeren: Dark grey fabric, *ext* glossy light grey or bronze-brown glaze with fine dark specks (*idem* 1964b).
- Plain Cologne: Pale grey-white fabric with pale grey glaze, often glossy, with fine black specks in glaze.
- Cologne-Frechen and Frechen: Dark grey fabric, usually with thick mottled dark brown glaze, occasionally mottled light grey (Reineking-von Bock 1971; Hurst 1974a).
- Siegburg: Very pale grey-white fabric with light cream surfaces, sometimes with red-brown patches (Beckmann 1974).
- Westerwald: Fine light grey fabric with blue-grey surfaces, normally decorated in blue or mauve (Reineking-von Bock 1971).

### English

- Surrey-Hampshire: Pale buff to white fabric, often rather sandy, occasionally soft red inclusions (Holling 1971; *idem* 1977; Haslam 1975).
- Bristol-Staffordshire yellow slipware: Fine buff or cream fabric without gross inclusions, glazed yellow, trailed slip glazed dark brown or black (Barton 1961; Kelly, Dawson and Price in Pearson 1979).
- Bristol stoneware: Fine light grey fabric without gross inclusions, mid brown salt glaze (*ibid.*).

### North Devon (Grant 1980)

- Gravel-free ware: Very fine clay matrix with a few angular quartz inclusions.
- Calcareous ware: Gravel-free fabric with the addition of much fine calcareous filler (? crushed shell) which commonly leaches out, leaving a pitted surface.
- Gravel-tempered ware: Fine matrix with abundant angular quartz and quartzite filler, sometimes with black or white mica plates.
- White ware: White pipeclay body.
- Glaze over the first three fabrics is almost invariably reduced green or brown. The gravel-free ware is commonly slip-coated and sgraffito-decorated; glaze over the white clay is always rich yellow (Watkins 1960).

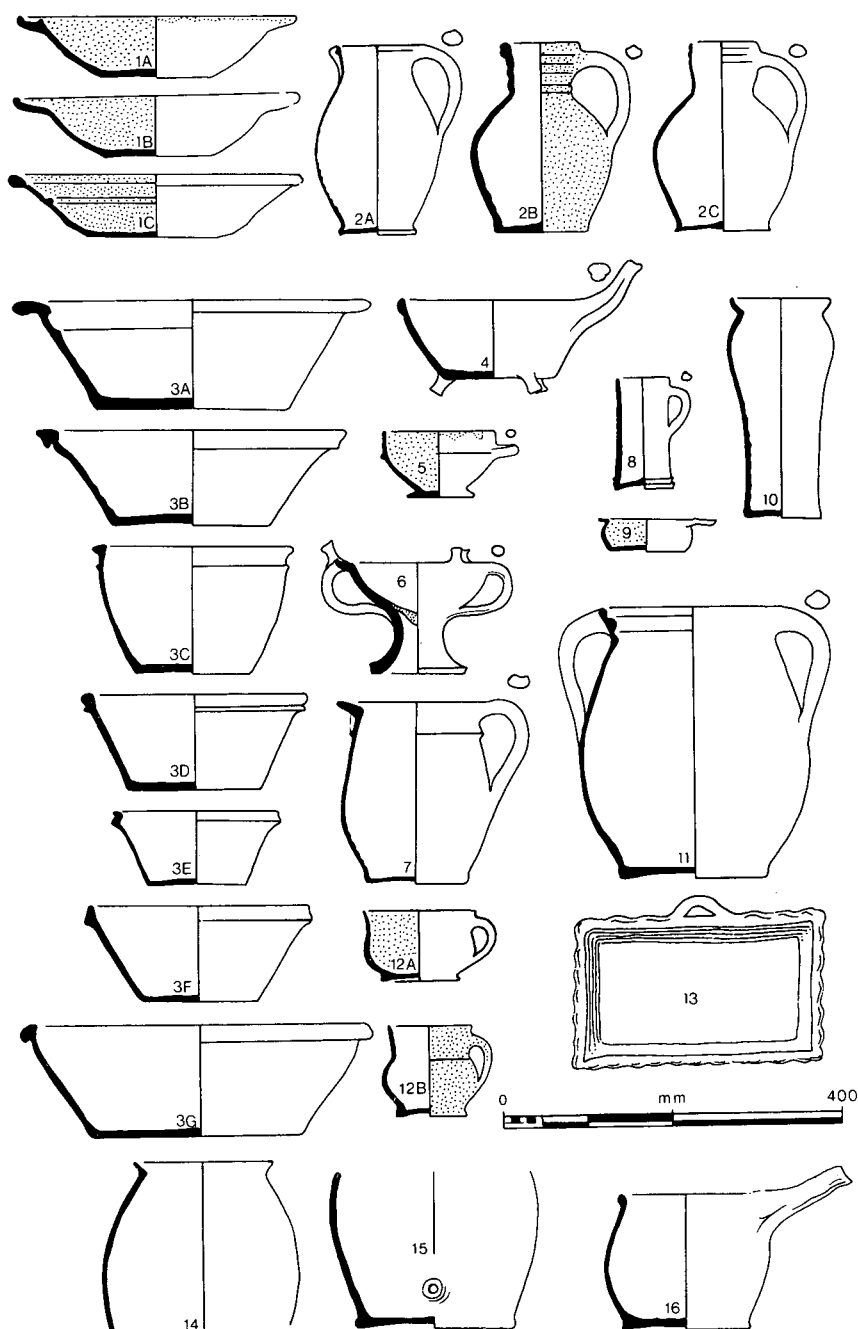

Fig. 63. Type-series of post-medieval North Devon pottery (scale 1:8).

#### *South Somerset*

Gritty ware: Rough fabric with rounded brown stone inclusions, chert fragments, quartz sand and iron oxide lumps.

Other 16th-century wares: The small and fine vessels usually lack gross inclusions. Larger vessels often contain some quartz-sand temper.

17th-century wares: Plain red earthenware with fine quartz-sand inclusions and scatter of iron oxide lumps (Hallam and Radford 1953).

18th-century wares: As above, but commonly firing to a paler buff-fawn colour (Pearson 1979).

#### *Other local fabrics*

Coarse Sandy ware: Fabric with much sandy filler, occasional

iron ore fragments and sparse ?chert fragments.

Totnes-type ware: Rough sandy fabric with micas and probable metamorphic rock inclusions. Distinctive reduced dark green glaze with black speckles.

St Germans-type ware: This term has been restricted to the thick wheel-thrown sherds usually with light grey surfaces when unglazed, with a little black or white mica, much quartz sand and a few brown stone inclusions (Gaskell Brown 1979).

South Devon micaceous wares: Sherds with a scatter of inclusions of black mica and ?metamorphic rock fragments suggestive of a source in a river clay derived from the granite. These do not occur in the St Germans kiln series, nor at Plymouth or in Cornwall, so South Devon is a likely source.



## C. THE TYPE SERIES OF LOCAL WARES

In the course of the present study it has become apparent that many post-medieval local wares were made in standardised forms, and the most common of these recur in many groups. The type series attempt a classification of these forms and are intended to avoid the continual repetition of the most common shapes in the corpus. A few of the most complete and best-dated examples of each of these have been drawn; had each vessel been illustrated, the corpus would have been very much longer. The series are not comprehensive; some vessel types present at Exeter are represented by single sherds whose forms cannot yet be reconstructed, and no attempt has been made to include forms known from excavations elsewhere which are absent from the city collection. In each series the number refers to the general vessel type (dish, bowl, etc.) and the letter to the precise rim-form and decoration.

## North Devon wares (Fig. 63)

- (1) Dishes. Gravel-free bodies; always with *int* slip which is commonly sgraffito-decorated.
- (2) Jugs. Bodies contain variable quantities of gravel; handles are gravel-tempered. 2A plain *ext*, glazed *int*. 2B with *ext* slip and sgraffito decoration, *int* glaze (illustration shows a complete example from Jamestown, Virginia: Watkins 1960, 36, Fig. 13). 2C plain *ext*, glazed *int*.
- (3) Bowls. Normally heavily gravel-tempered body with *int* glaze, commonly sooted *ext*. Classification is based entirely on rim form: there is a considerable variety of sizes.
- (4) Tripod skillets. Gravel-tempered, glazed *int*, usually sooted. Some vessels listed in the catalogue have been identified from foot or handle fragments and may have had different body forms.
- (5) Porringers. Usually gravel-free bodies with gravel-tempered handles; glaze *int*, sometimes slip-coated *int*.
- (6) Chafing dishes. Usually gravel-tempered, glazed inside bowl (illustration shows a complete example from Jamestown, Virginia: *ibid.*, 42, Fig. 20).
- (7) Chamber pots. Gravel-tempered or gravel-free body, some with plain slip or sgraffito decoration.
- (8) Tankards. Gravel-tempered and gravel-free. *Int* and *ext* glaze, sometimes *ext* slip.

- (9) ?Saucers. Gravel-free, sgraffito-decorated.
- (10) Tall jars. Usually gravel-free or calcareous fabric; glazed *int*.
- (11) ?Crocks. Usually gravel-tempered; glazed *int*. Some may have one handle or more. Tripod feet sometimes occur on bases.
- (12) Cups. Gravel-free. Usually *int* slip, some with *ext* sgraffito decoration (illustration 12B shows a complete example from Plymouth: Gaskell Brown 1979, 59, No. 35).
- (13) Baking pans. Some lack the pie-crust rim (illustration shows a complete example from Jamestown, Virginia: Watkins 1960, 42, Fig. 21).
- (14) Jars. Calcareous fabric with *int*, often rather patchy, glaze.
- (15) Cisterns. Gravel-free or calcareous fabric with *int*, often rather patchy, glaze.
- (16) ?Handled cooking pots. Gravel-tempered, glazed *int*.

## South Somerset 15th/16th-century types (Fig. 64)

- (1) Bowls with *int* glaze, usually sooted.
- (2) Jugs with *ext* glaze, 2A with broad flat handles, 2B with twisted handles. Both types are sometimes decorated (1757, 1802, 1811); there is a great variety of vessel shapes and decorative features.
- (3) Cisterns with *ext* glaze.
- (4) Cooking pots in gritty ware with *int* glaze on base and rim.
- (5) Tripod pipkins with *int* glaze on rim and base, sooted *ext*.
- (6) Cups with fine light grey fabrics, and all-over glaze. 6A Raeren copies.
- (7) ?Measure (holding one pint), single example.
- (8) Chafing dishes. Richly glazed *int* and *ext* of bowl.
- (9) Condiment dish or ?saucer. Glazed *int*.
- (10) Small handled dish.
- (11) Cucurbit in gritty ware. Glazed *int*.
- (12) Storage jar. Glazed *int*.

## South Somerset 17th-century types (Fig. 65)

- (1) Bowls with *int* glaze, all except 1A normally unsooted.
- (2) ?Bowls with *int* decoration and glaze, none sooted. 2A-B with yellow-glazed slip and sgraffito decoration; 2C with yellow-glazed slip and sgraffito decoration, with red glaze on body; 2D-F with yellow-glazed *int* slip.

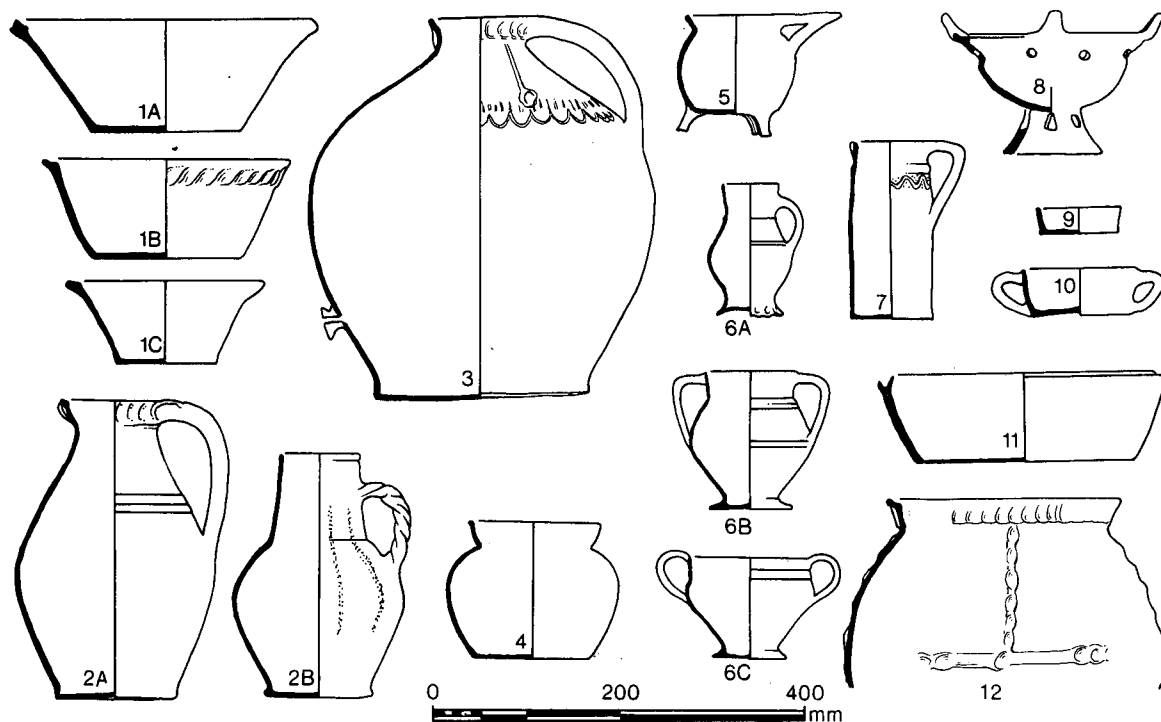

Fig. 64. Type-series of 15th/16th-century South Somerset pottery (scale 1:8).

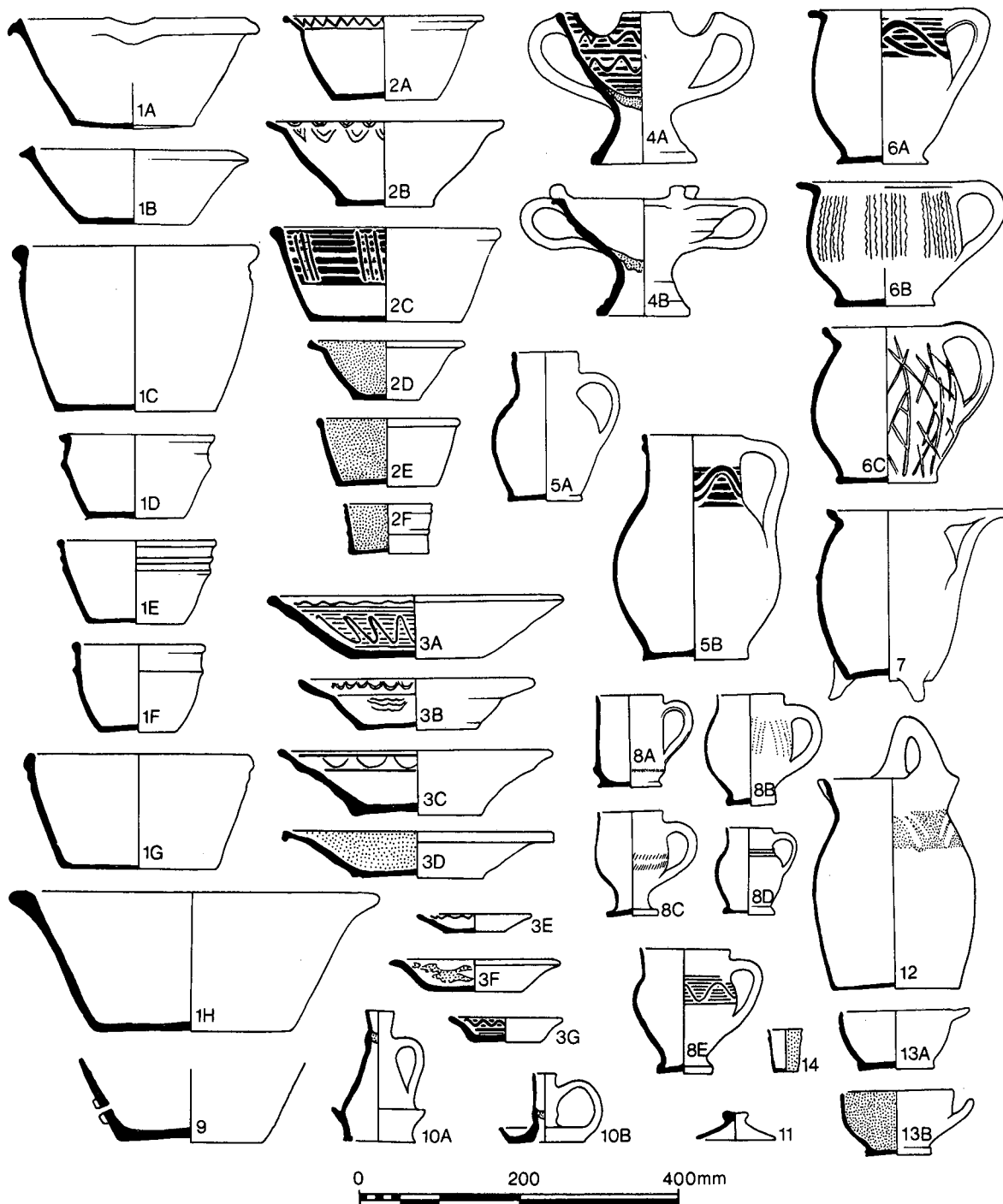

Fig. 65. Type-series of 17th-century South Somerset pottery (scale 1:8).

- (3) Dishes. 3A with spiral style single-line sgraffito, glazed yellow over slip, usually orange-red over glaze (variety of rim forms). 3B-C with yellow-glazed slip and sgraffito, 3D with *int* slip, glazed yellow, sometimes copper-mottled. 3E-G small versions, 3E decorated as 3B, 3F with splashed slip, 3G decorated as 3A.
- (4) Chafing dishes with cut-out rims (4A) or horned rims (4B).
- (5) Jugs. 5A black-glazed, 5B with *int* and partial *ext* glaze.
- (6) Chamber pots with *int* glaze, 6B-C with all-over slip and sgraffito decoration.
- (7) Tripod pipkins. Glazed *int*, sometimes sooted.
- (8) Cups with black glaze (8A, 8C), lead glaze with trailed slip (8B), plain *ext* (8D) or band of slip with single-line sgraffito (8E).
- (9) Cisterns with *int* glaze on base.
- (10) Candlesticks.
- (11) Unglazed lids.
- (12) Bucket-handled pots. Glazed *int*.
- (13) Porringers with solid (13A) or horizontal (13B) handles.
- (14) Ointment pots.

*South Somerset 18th-century types (Fig. 66)*

- (1) Dishes, all plain *ext*. 1A with *int* combed sgraffito decoration over wet slip. Slip covers the rim and often covers the base; the walls are unslipped. Glaze over body is most commonly mid green with orange patches, but can also be orange, red or green-brown; over slip it is usually cream-yellow. 1B Broad blade sgraffito-decorated dishes with *int* slip, glazed yellow or light green-yellow, with specks of iron-bleeding. 1C with all-over combing on dry slip. 1D with double slips, feathered in imitation of Bristol and Staffordshire slipwares. Glazed black, dark brown or green-brown over dark slip, yellow over white slip.
- (2) Cups. 2A-B with *int* slip, and speckles of copper green applied to slip giving mottled mid green glaze. 2C with

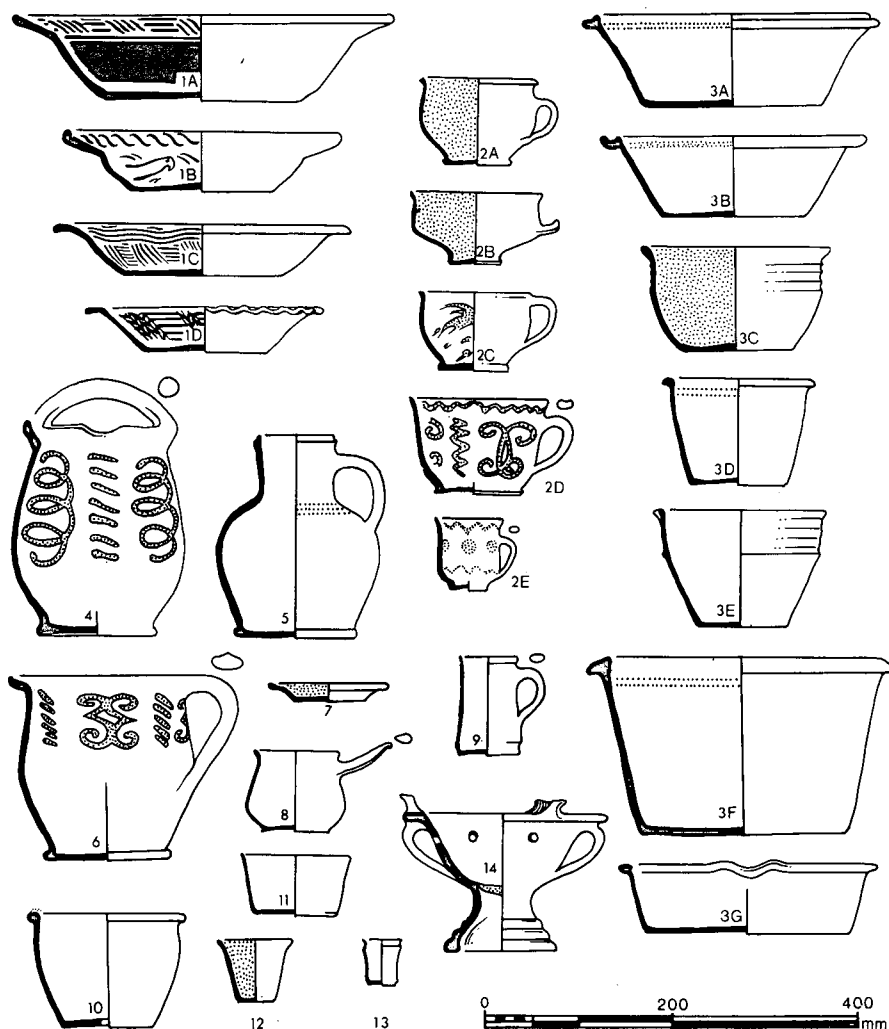

Fig. 66. Type-series of 18th-century South Somerset pottery (scale 1:8).

- splashes of *int* slip, perhaps applied with a brush. Glazed orange, brown or red-brown over body. 2D with trailed scroll decoration, glazed *int* and *ext* with mid green glaze, often with bright orange patches. 2E small cups with trailed slip, glaze as 2D.
- (3) Bowls, plain *ext*. 3A–B large bowls with *int* slip bands. Glaze *int* only. Glaze almost invariably as 2D. Not sooted. 3C ?bowl with *int* slip and copper-green glaze, applied as in 2A, 2B. Not sooted. 3D small bowl or jar with bands of *int* slip, glaze light or dark brown, orange, light green, or orange-red, usually with speckles or iron-bleeding. There is some minor variation in the rim forms of this type. 3E tall bowls with corrugated sides, glazed as 3D. 3F large deep bowls. Usually dark brown or orange-brown glaze. 3G pan, glaze as 3D. (Included in list of bowls, as not distinguishable from bowls when fragmentary.)
  - (4) Bucket-handled pots. *Int* and top two-thirds of *ext* glazed mid green with orange spots, or brown.
  - (5) Jugs. Glaze as 4.
  - (6) Chamber pots. Glaze as 4.
  - (7) Small plates with slip and copper green glaze as 2A, 2B.
  - (8) Small pipkins. Glaze as 3D.
  - (9) Tankards. Mid green or brown glaze.
  - (10) Flowerpots. Unglazed.
  - (11) ?Small bowls. Glaze as 3D.
  - (12) Possible drug jar. Glaze as 2A, 2B.

- (13) Drug jars. Glaze as 3A.
- (14) Chafing dishes with orange, orange-brown or green glaze.

#### Coarse Sandy wares (Fig. 67)

- (1) Bowls. Always glazed *int* and unglazed *ext*. Usually sooted *ext*. Type 1B has an applied thumbled strip below the rim.
- (2) Jugs with *int* glaze, strap handles, pulled lips, applied thumbled strips below neck, and unglazed slip band with incised lines.
- (3) Tripod pipkins with *int* glaze, usually sooted *ext*.
- (4) Jars. 4A tall, 4B squat, glazed *int*.
- (5) Copies of metal cauldrons. Glazed *int*, sooted *ext*.
- (6) ?Bottle. One example, unglazed.
- (7) ?Chamber pots with *int* glaze. Some have unglazed slip bands on shoulder with incised lines.
- (8) Flat wheel-thrown pans with *int* glaze, sooted *ext*.
- (9) Large storage jars, perhaps with some specific function in view of the unusual rims. Glazed *int*.
- (10) Tall jars. Glazed *int*.

In all instances the fabric contains coarse quartz-sand grains, with very few other inclusions. Glaze is most commonly a reduced dark green, especially in the large closed forms, but oranges, browns, light yellowish-greens and reds are also found.

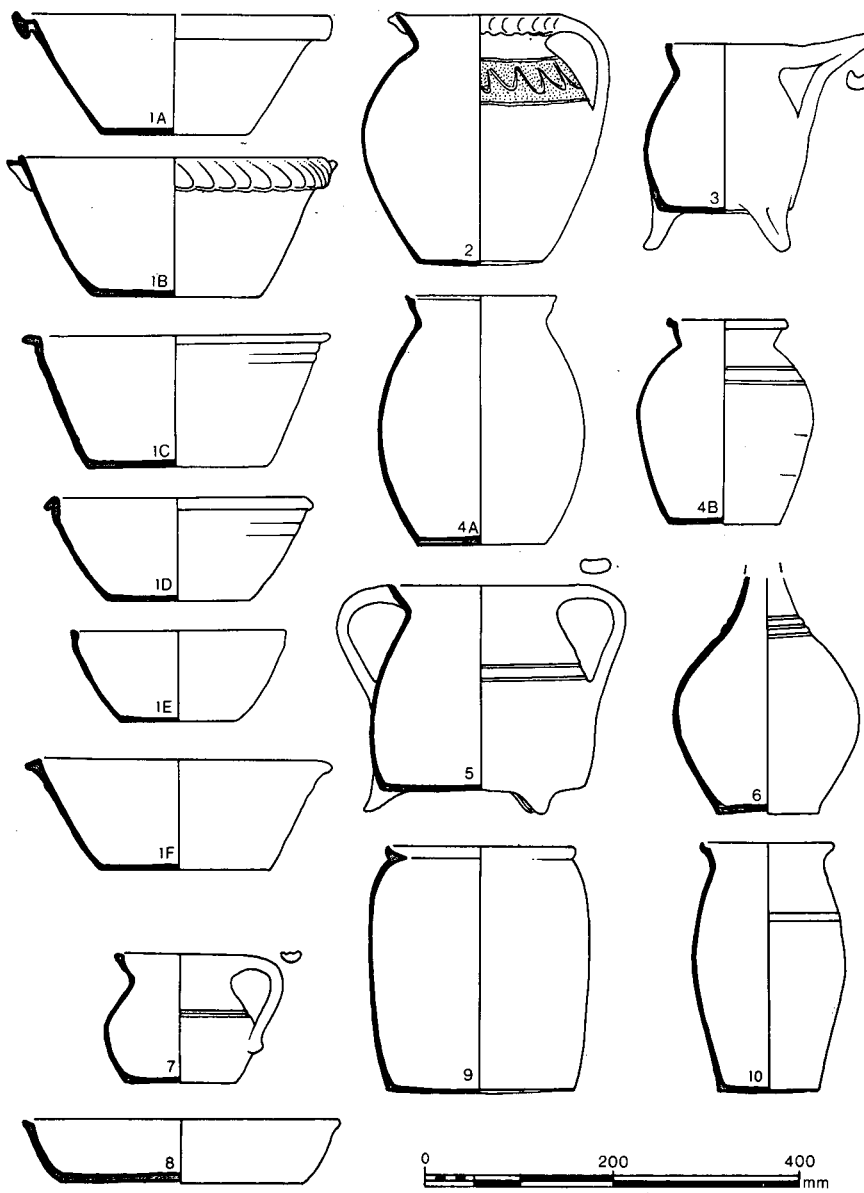

Fig. 67. Type-series of Coarse Sandy wares (scale 1:8).

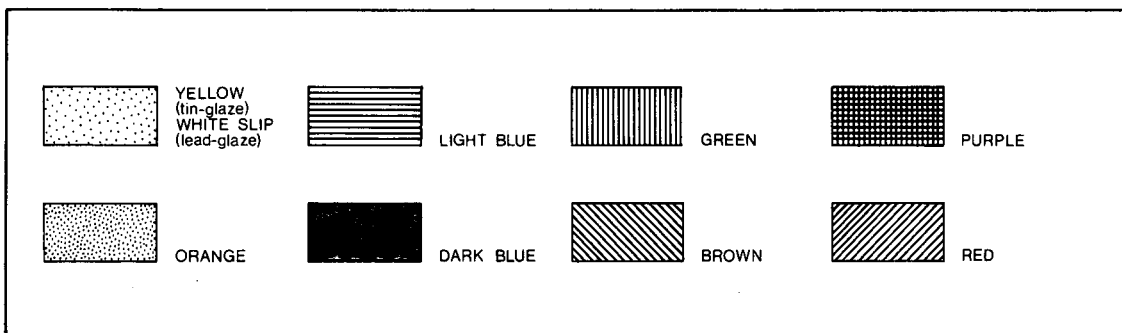

Fig. 68. Post-medieval pottery: colour code.

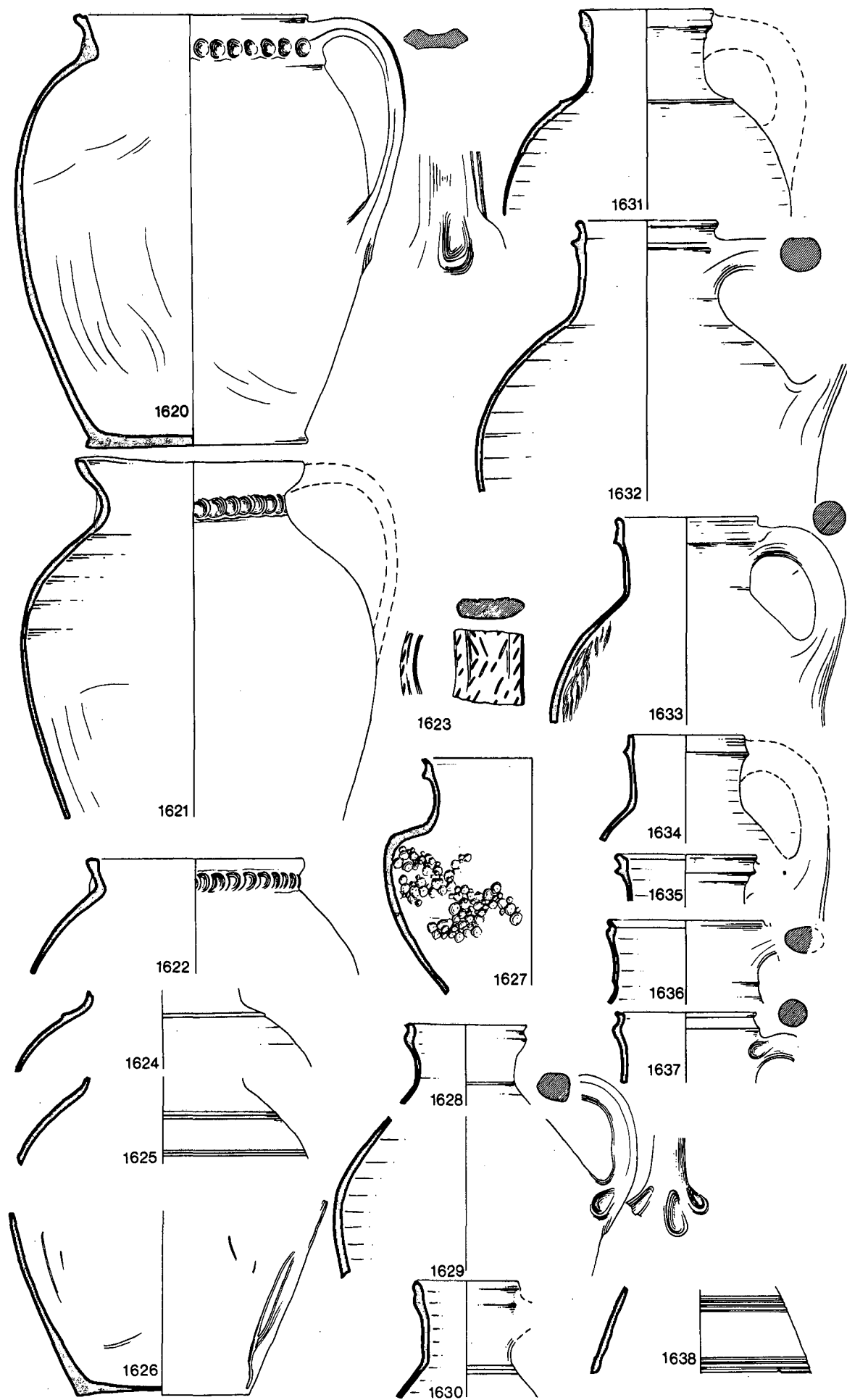

Fig. 69. Goldsmith Street kiln wares, early 16th-century (scale 1:4).

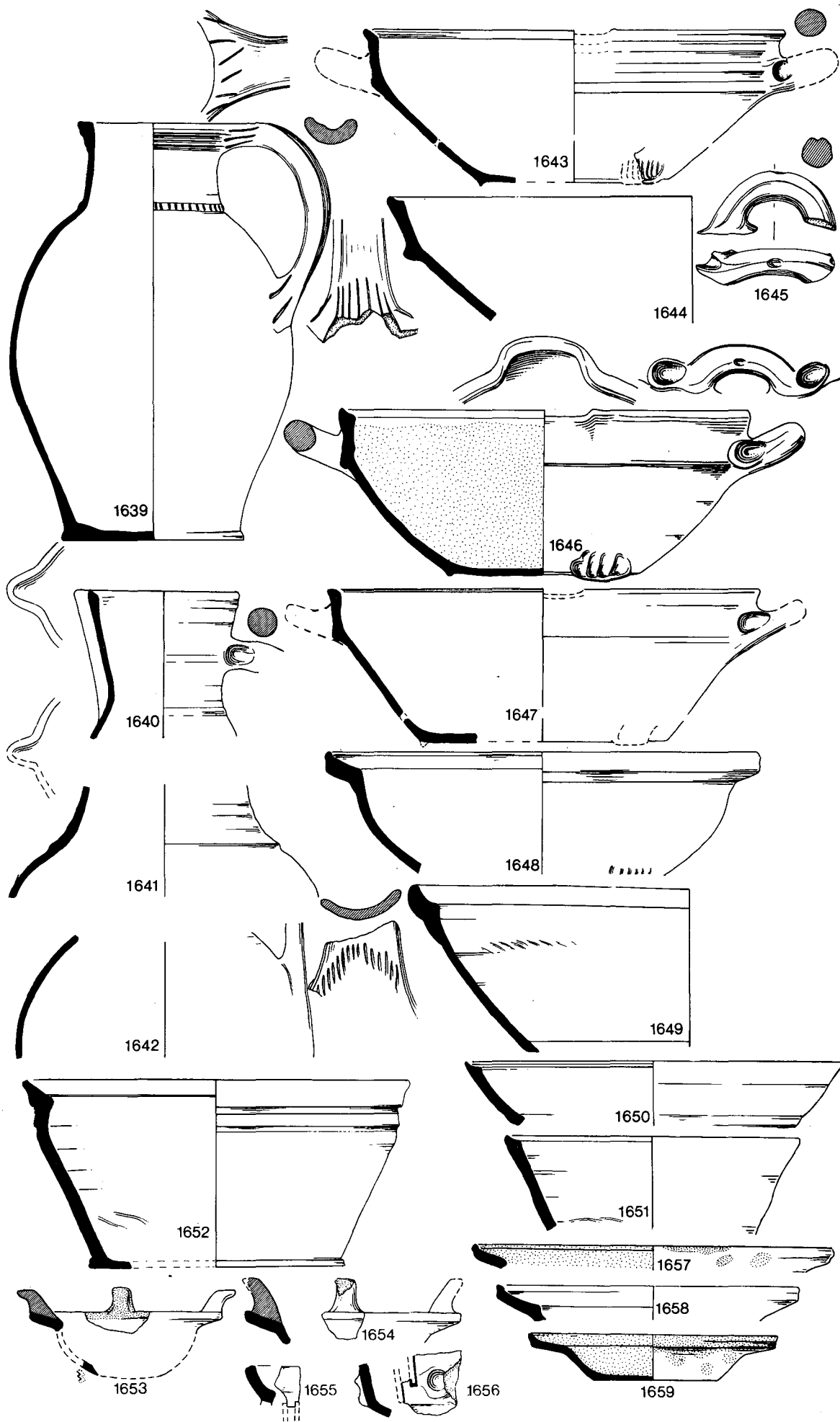

Fig. 70. Goldsmith Street kiln wares, early 16th-century (scale 1:4).

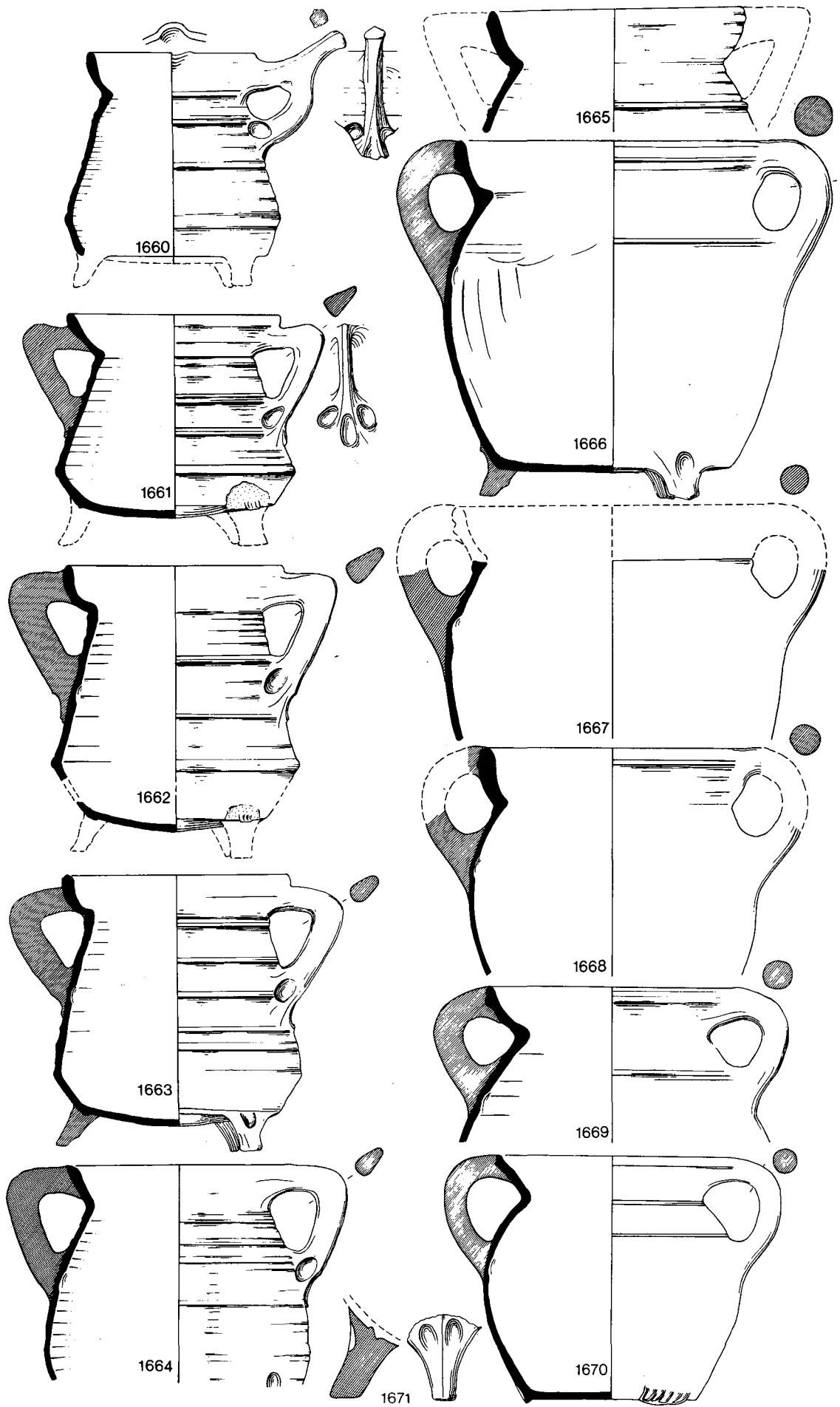

Fig. 71. Goldsmith Street kiln wares, early 16th-century (scale 1:4).

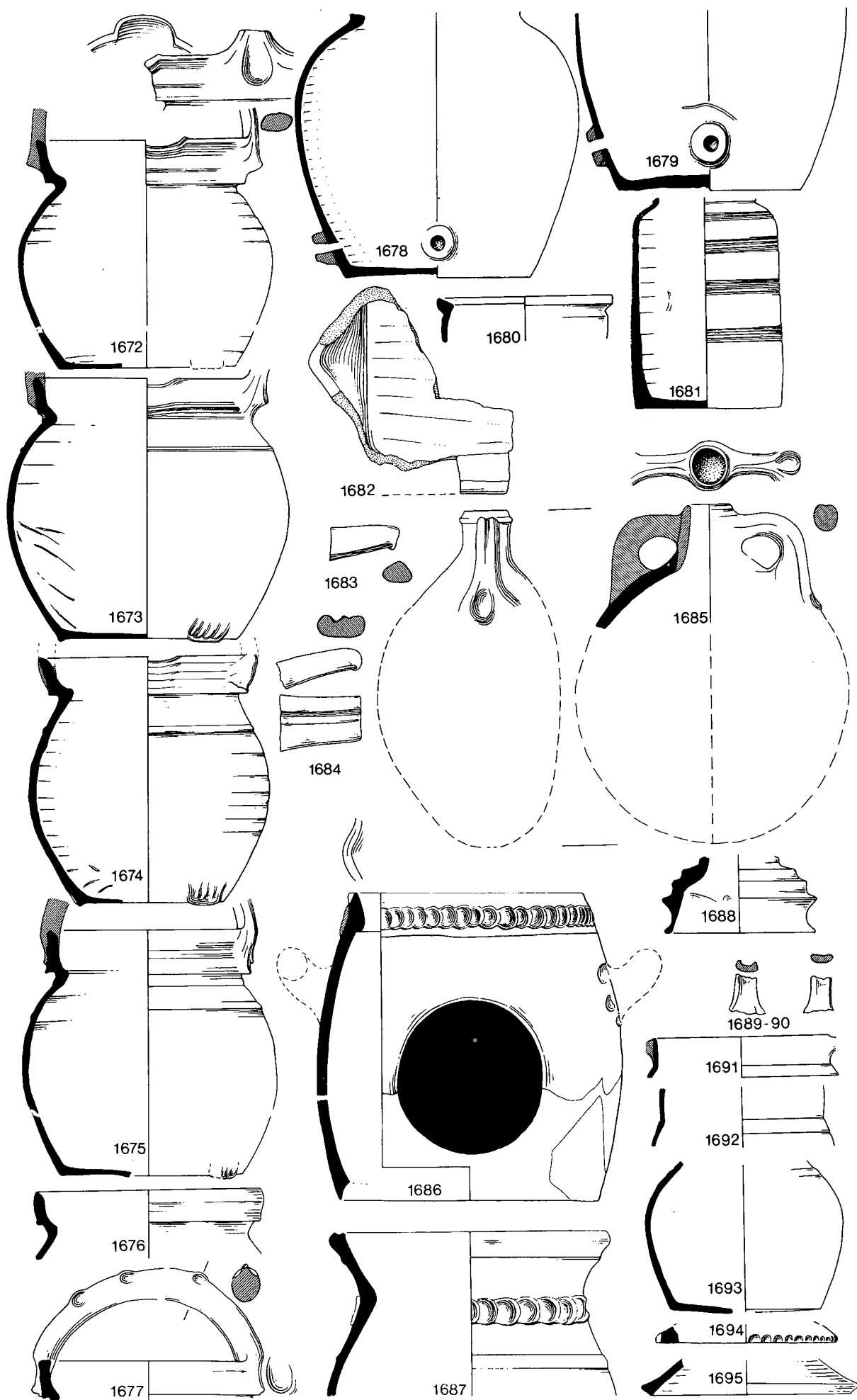

Fig. 72. Goldsmith Street kiln wares, early 16th-century (scale 1:4).



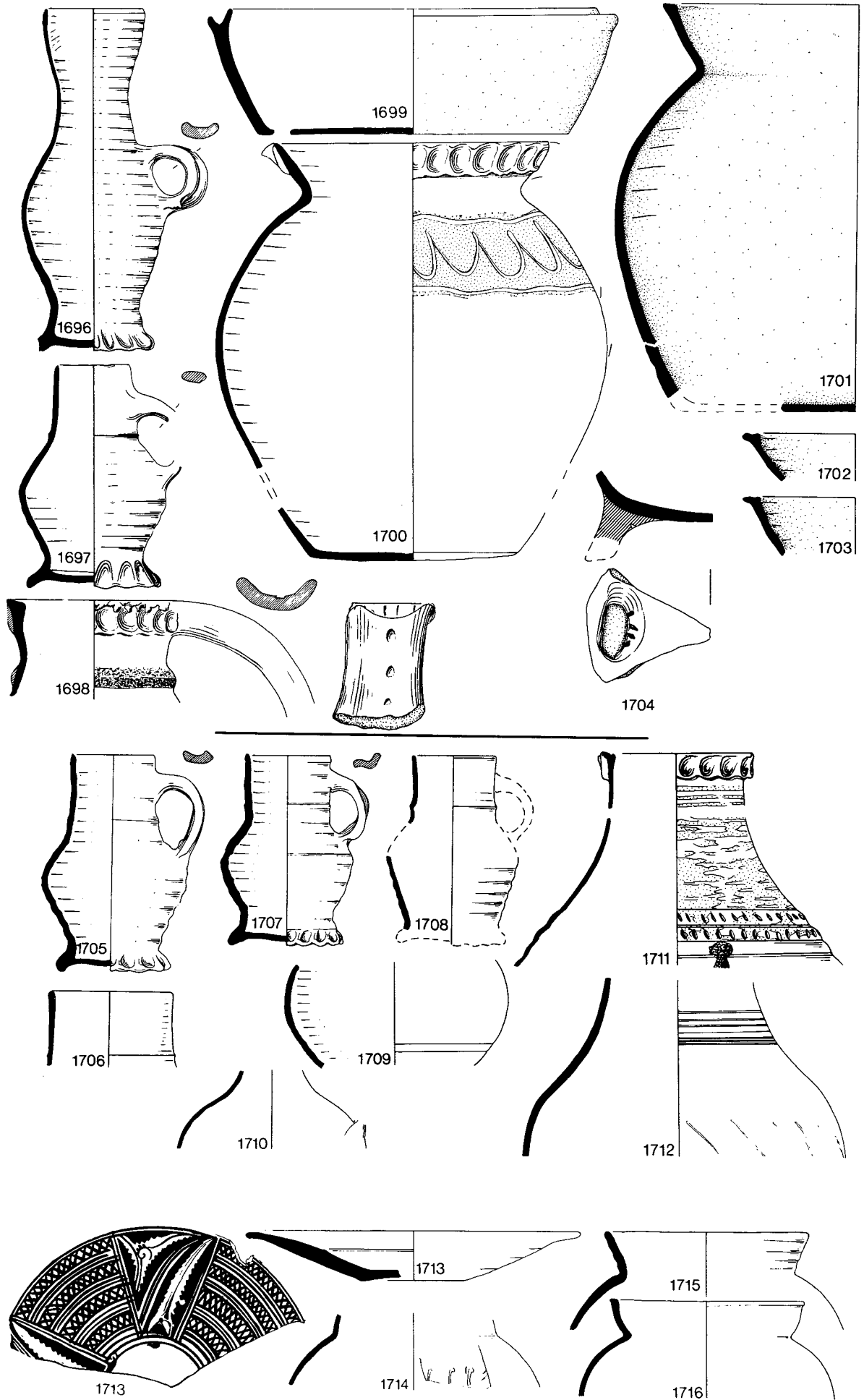

Fig. 73. Early 16th-century pottery associated with Goldsmith Street ware (scale 1:4).

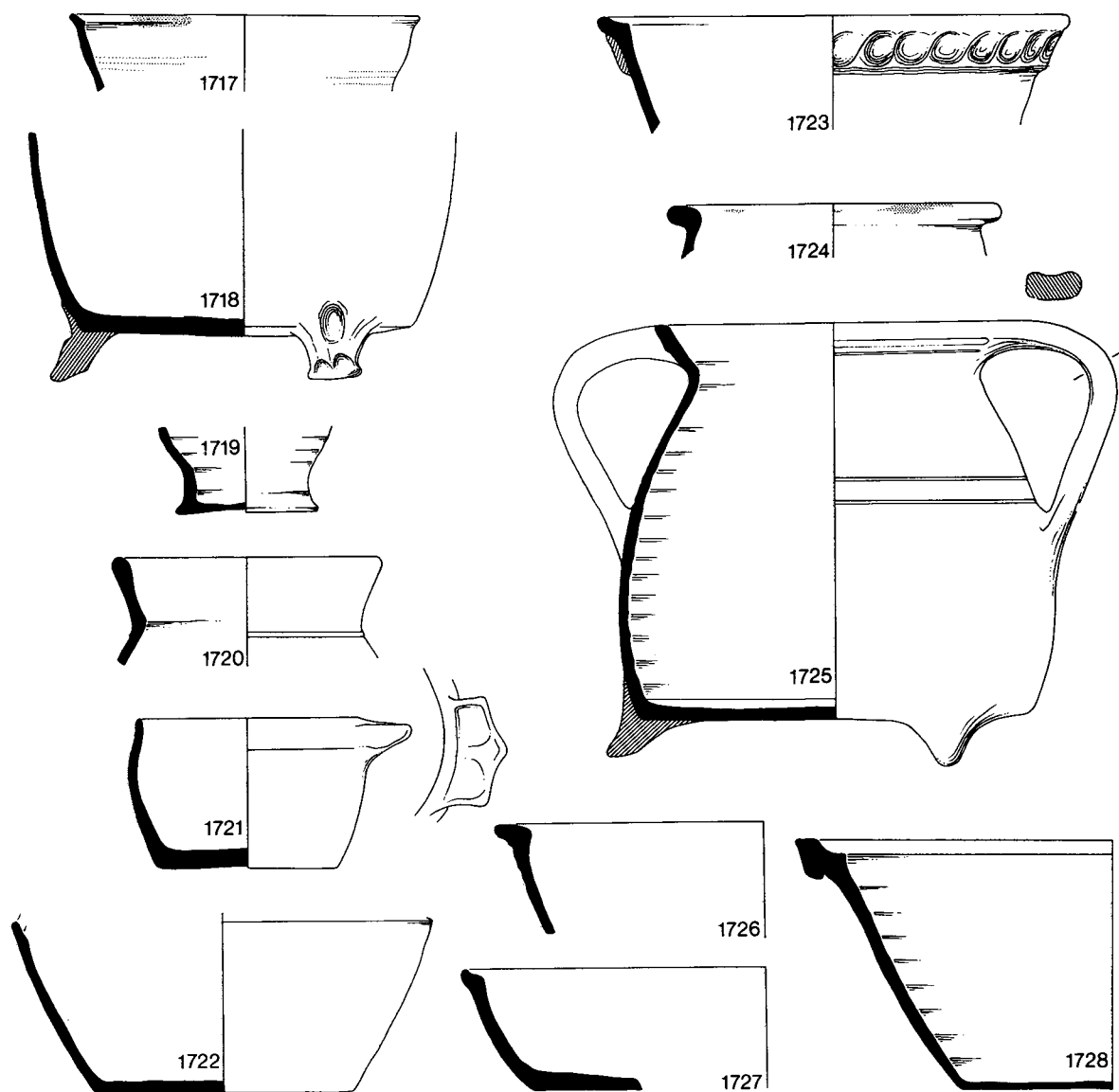

Fig. 74. Goldsmith Street 201, early 16th-century (scale 1:4).

#### D. THE CORPUS

GOLDSMITH STREET 264 and 290 (Figs. 69–73)

**1620–95** Goldsmith Street kiln products. **1646, 1653–7** and **1659** with thick *int* slip. (Details in MF 67–76; discussion on pp. 136–8).

*Pottery in other fabrics associated with kiln wares (15th/16th-century types).*

- 1696** Raeren jug of *Jacoba* form.  
**1697** Raeren mug.  
**1698** South Somerset type 2 jug with a fine oxidised fabric; metallic band over applied ridge on body.  
**1699** Type 11 cucurbit in South Somerset gritty ware with *int* glaze. Heavily sooted unglazed *ext* (cf. Moorhouse 1972a, 111–21).  
**1700** Coarse Sandy ware type 2 jug. Unglazed *ext*, band of slip with incised line decoration. *Int* glaze on base and rim. Pulled lip.  
**1701–3** South Somerset type 4 gritty wares, heavily sooted *ext*.  
**1704** Coarse Sandy ware base (?type 5). Stabbed inside edge of foot, *ext* sooting.

Date: c. 1500–50.

RACK STREET 36 (Fig. 73)

Pit group.

- 1705–7** Raeren mugs.  
**1708** Langerwehe stoneware mug. The form is uncertain, but since it has the typical neck profile of Raeren wares it has been reconstructed as a Raeren copy.

- 1709** Bodysherd from plain Cologne mug.  
**1710** Bodysherd of Beauvais stoneware with stub of folded handle, confirming the identification as Beauvais rather than Siegburg.  
**1711** Typical fine South Somerset 15th/16th-century type 2 jug with thin *ext* slip, and applied strip on body covered with metallic wash.  
**1712** Jug in an oxidised fabric without gross inclusions, with green-brown glaze, possibly Goldsmith Street ware.

*Not ill:* Coarse Sandy ware, indicating a date after c. 1500.  
 Date: c. 1500–50.

TRICHAY STREET 156 (Fig. 73)

Pit group.

- 1713** Valencian tin-glazed plate. Hard pink fabric with sparse calcareous inclusions and fine rounded brown inclusions up to 2 mm. Buff surfaces under a thin glaze on both sides. Fairly obvious lustre on top surfaces (shown black), 'thistle' pattern typical of the last quarter of the 15th century (von Brigitte Klesse 1966, No. 167). No lustre visible on back. A complete example showing almost identical decoration has been published from Worcester (Morris 1978, 83, No. 1088/1).  
**1714** South Somerset 15th/16th-century type 2 jug with sgraffito lines through slip.  
**1715–16** South Somerset type 4 cooking pots.  
*Not ill:* Goldsmith Street type 1B handle.  
 Date: c. 1500–50.

## GOLDSMITH STREET 201 (Fig. 74)

Pit group.

*Glass:* G.60-2, 16th-century types.

- 1717** Unglazed St Germans-type ware.  
**1718** Goldsmith Street type 6B base, with typical thumbled pod foot and speckled glaze.  
**1719-21** Possible Goldsmith Street wares, although none is precisely paralleled in the kiln group. All have the fine fabric without gross inclusions, and their glaze colours are similar to those of kiln products.  
**1722-4** South Somerset bowls and jar.  
**1725-8** Coarse Sandy wares, types 5, 1A, 8, 1C; **1728** sooted.

*Not ill:* S. Neths. maiolica sherd; Coarse Sandy types 1A, 1E.  
*Date:* c. 1500-50.

## GOLDSMITH STREET 228 (Figs. 75-7)

This group comes from the upper fill of the large stone-lined pit whose lower fills contained Saintonge polychrome jugs (1446-7) and other 14th-century finds. The upper layers are clearly early 16th-century in date, with a few late 15th-century items. Either the pit was cleaned out after a period of disuse or it was in use for about two centuries. The pit TS 316 poses a comparable problem (p. 180).

*Summary of dating evidence:**Glass:* (G.49-57) including G.49, 16th-century.*Leather:* (L.28-31) L.8: group with late 15th-century pieces and one of c. 1520-50.*Numismatics:* (J.11, 12a, 12b) L.13 (below group): late 15th/early 16th-century.*Imports*

- 1729** Complete Siegburg stoneware jug with pewter lid and remnants of pewter sleeve on handle.  
**1730-5** Raeren mugs.  
**1736** Langerwehe mug with all-over dark brown wash.  
**1737-45** Cologne jugs. **1737-41** decorated; **1742-5** plain. **1737a-b**, **1739**, **1741** stamps shown at half actual size. **1737c**, **1740** extended views of designs.  
**1746** (From top surface — not firmly stratified.) Fragment of a Saintonge chafing dish with adjacent areas of yellow and green glaze.  
**1747** Martincamp type I flask.  
**1748** Plain unglazed Saintonge jug with stamp on handle, sooted base.

*English wares*

- 1749** Cup sherd in 'Cistercian' tradition with reduced dark grey fabric and dark mauve glaze.  
**1750** ?Cistern in South Devon micaceous ware.  
**1751** Two-handed cup in a fine light grey fabric with all-over slip and copper-mottled green glaze. The form and glaze imitate Tudor Green wares. Cups of this type were made in South Somerset but several examples have also been excavated at Barnstaple, where they were presumably local products. Source uncertain.  
**1752-62** South Somerset 15th/16th-century types. **1752** type 6C cup; **1753** type 6B cup; **1754** cucurbit, sooted *ext*, glazed *int*; **1755-6** ?small dishes; **1757-9** jugs; **1760** type 8 chafing dish (base with cut-outs, possibly a different vessel from top); **1761** type 7 measure with two sgraffito bands and glaze on *ext*; **1762** type 3 cistern.  
**1763-74** Probable South Somerset wares. **1763-7** jar and rims with *int* glaze; **1768** cucurbit with *int* glaze, *ext* sooting; **1769** small bowl; **1770** alembic spout, glazed *ext*; **1771** ?cup base with dark mauve *int* and *ext* glaze; **1772** unglazed handle; **1773** rim with *int* glaze; **1774** unglazed water-pipe, one of several in the group.  
**1775-81** Coarse Sandy wares. **1775-9** bowls, types 1A, 1B, 1E, 1E; **1780** ?jar with *int* glaze; **1781** type 2 jug.  
**1782** Goldsmith Street ware rim.  
**1783** Small ?money box, probably South Somerset.  
*Date:* c. 1500-50.

## ST NICHOLAS PRIORY (Fig. 78)

This group comes from the backfilling of the robbed wall trenches of the nave and nave aisle of the priory church (cf. Webster and Cherry 1972, 173). The priory was suppressed in

1536, and the demolition of the priory buildings followed shortly afterwards. In 1538 materials from its cloister were used in the construction of the city's new yarn market (MacCaffrey 1958, 75); in 1539 great quantities of stone from the priory were used in repairs to the city wall and Exe Bridge (Youings 1960, 14-16; Parry and Brakspear 1917, 19-20). The group therefore belongs to the years after 1536, and probably shortly after that date. This is confirmed by the character of the imports, with Raeren and Cologne stonewares and Beauvais drinking jugs but no Frechen sherds, suggesting a date before c. 1550.

*Imports*

- 1784** Plain Saintonge jug, unglazed except glaze spots on body. This could have had a bucket handle.  
**1785** Valencian tin-glazed dish sherds (Hurst 1977a). On back, faint traces of horizontal lustre lines; on front no lustre visible, edge of impressed design.  
**1786-7** Beauvais drinking jugs. **1786** glazed yellow with edge of an applied medallion; **1787** glazed green, profile reconstructed from overlapping sherds. A total of two green-glazed and three yellow-glazed jugs, plus one Beauvais sgraffito-decorated sherd with a single brown slip, are present in this group.  
**1788-9** Sherds from Cologne stoneware mugs with applied leaves and rosettes.  
**1790** Unburnished Merida-type sherd.  
**1791-4** Raeren stonewares.  
*Not ill:* Costrel sherd of Goggin's 'early style' (Goggin 1960, 8-11) but with light buff fabric with quartz and fine rock inclusions; Martincamp type I.

*Local wares*

- 1795** Chafing dish base. South Devon micaceous ware.  
**1796** Jar. Hard-fired brown fabric with ?rounded fine sandstone inclusions and possible white mica plates. Surfaces heavily weathered, no glaze survives.  
**1797-1806** South Somerset 15th/16th-century wares. **1797** ?cup; **1798** type 6B cup; **1799** type 6 cup; **1800** base of a type 6B cup; **1801** jug handle; **1802** type 2A jug with band of slip and incised decoration; **1803** type 2A rim; **1804** jug top; **1805** type 2A jug top; **1806** rim, possibly South Somerset.  
**1807-9** Coarse Sandy wares. **1807** type 1E bowl; **1808** type 1A bowl; **1809** type 4A.

*Not ill:* Coarse Sandy types 1A, 4A; N. Devon gravel-tempered sherds.

*Date:* c. 1536-50.

## GRANDISSON'S TOMB (Fig. 79)

The following vessels were recovered in the 1950s from the grave of Bishop John Grandisson in Exeter Cathedral (anon. 1957). Grandisson died in 1369; his tomb was opened and rifled between 1556 and 1586 (*ibid.*). The pottery is clearly 16th-century in character, and coins of Elizabeth I were found in association with it. The group is therefore dated after 1556 and probably before 1586.

- 1810** Unglazed St Germans-type or Totnes-type ware with faint slip lines.  
**1811-14**, **1816** South Somerset jugs. **1811** with spots of slip; **1812** with traces of slip on shoulder; **1813** form copying stonewares, fired upright; **1814** type 2A; **1816** with stub of plaited handle.  
**1815**, **1817** Coarse Sandy wares, types 4B, 4.

## TRICHAY STREET 599 (Fig. 79)

Pit group.

- 1818** South Somerset 15th/16th-century type 6A. The form copies Raeren mugs; reconstruction based on a complete example from Taunton excavations.  
**1819** Tudor Green ware cup.  
*Date:* Late 15th/early or mid 16th-century.

## RACK STREET 115 (Fig. 79)

Pit group.

*Contamination:* 15 late 17th-century sherds. This feature was evidently badly dug.

*Relations:* Cut by RS 63 containing 2735.

- 1820** Raeren or Aachen stoneware sherd from a vessel with a high shoulder.  
**1821** Sevillian sherd in *cuerda seca* technique with a buff

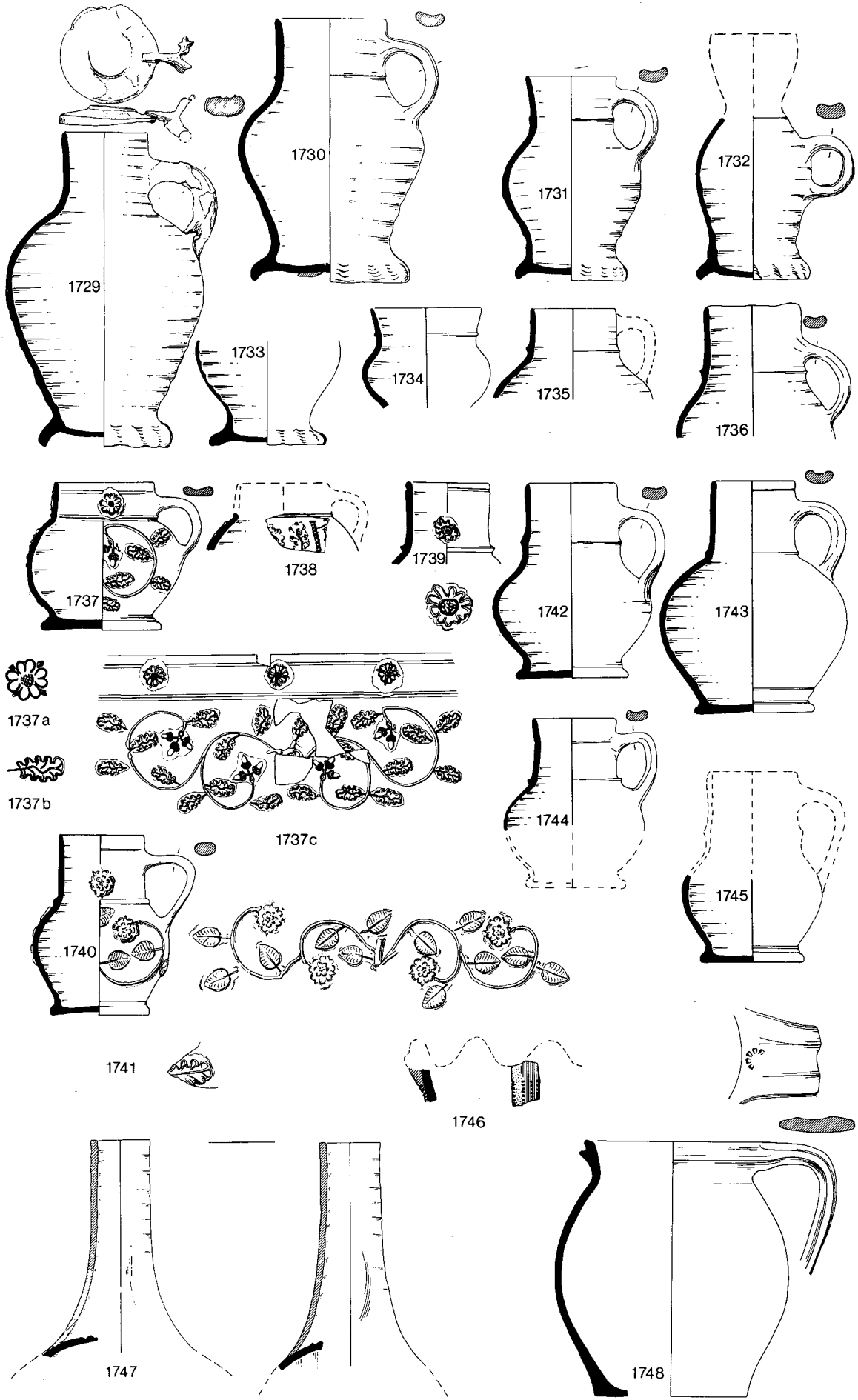

Fig. 75. Early 16th-century imports from Goldsmith Street 228 (scale 1:4).

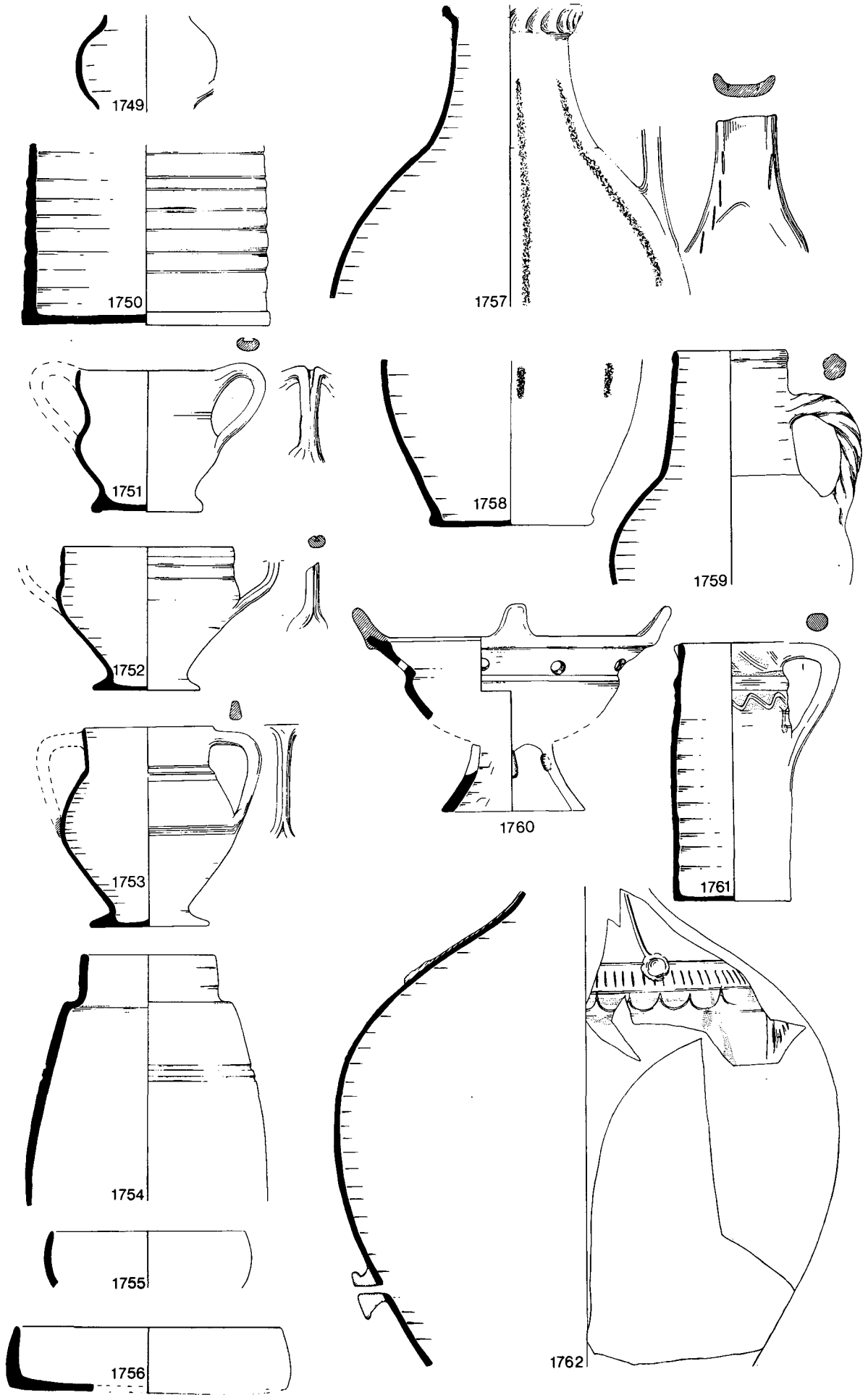

Fig. 76. Early 16th-century local wares from Goldsmith Street 228 (scale 1:4).

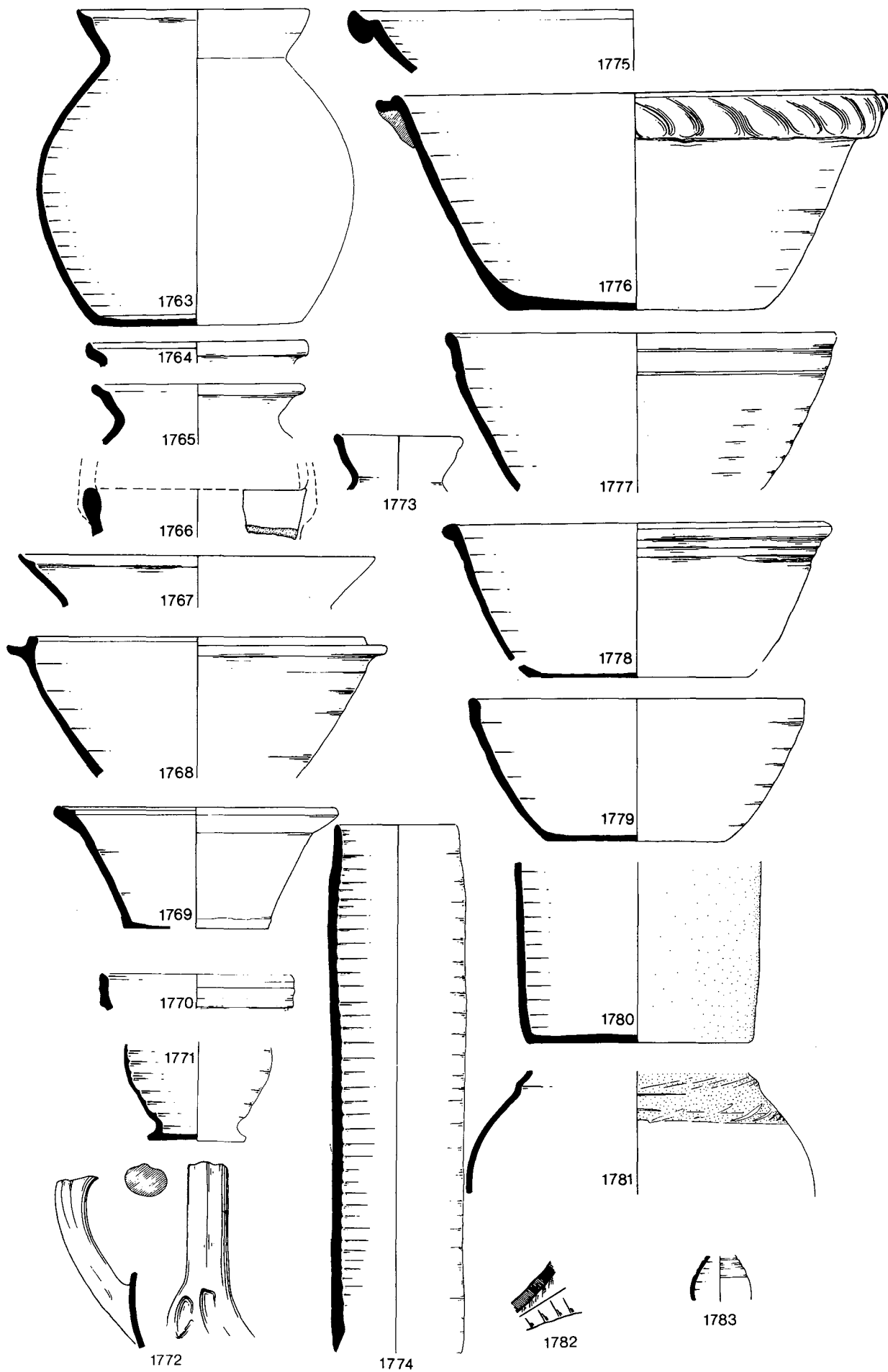

Fig. 77. Early 16th-century local wares from Goldsmith Street 228 (scale 1:4).

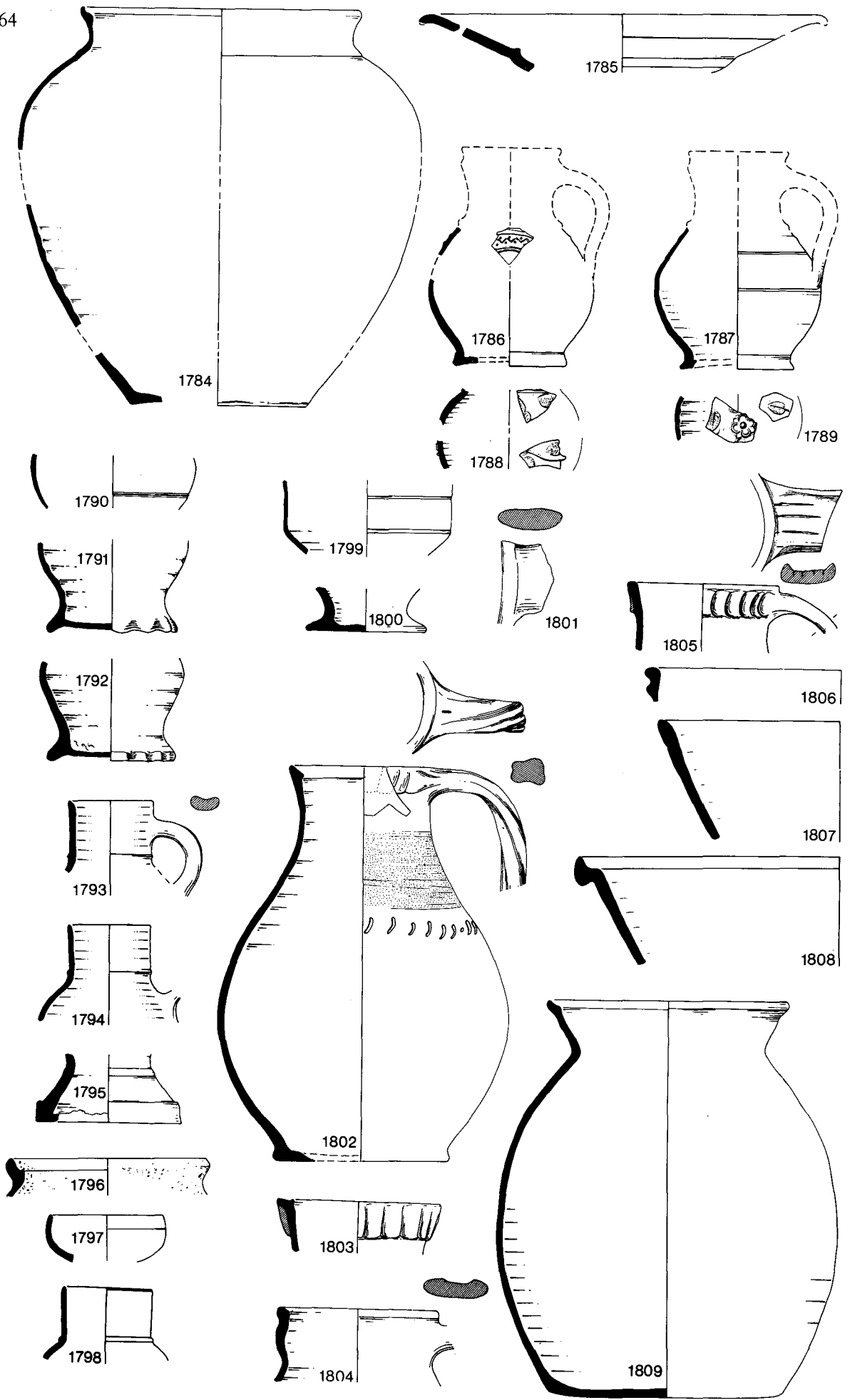

Fig. 78. St Nicholas Priory, 1536-c.1550 (scale 1:4).

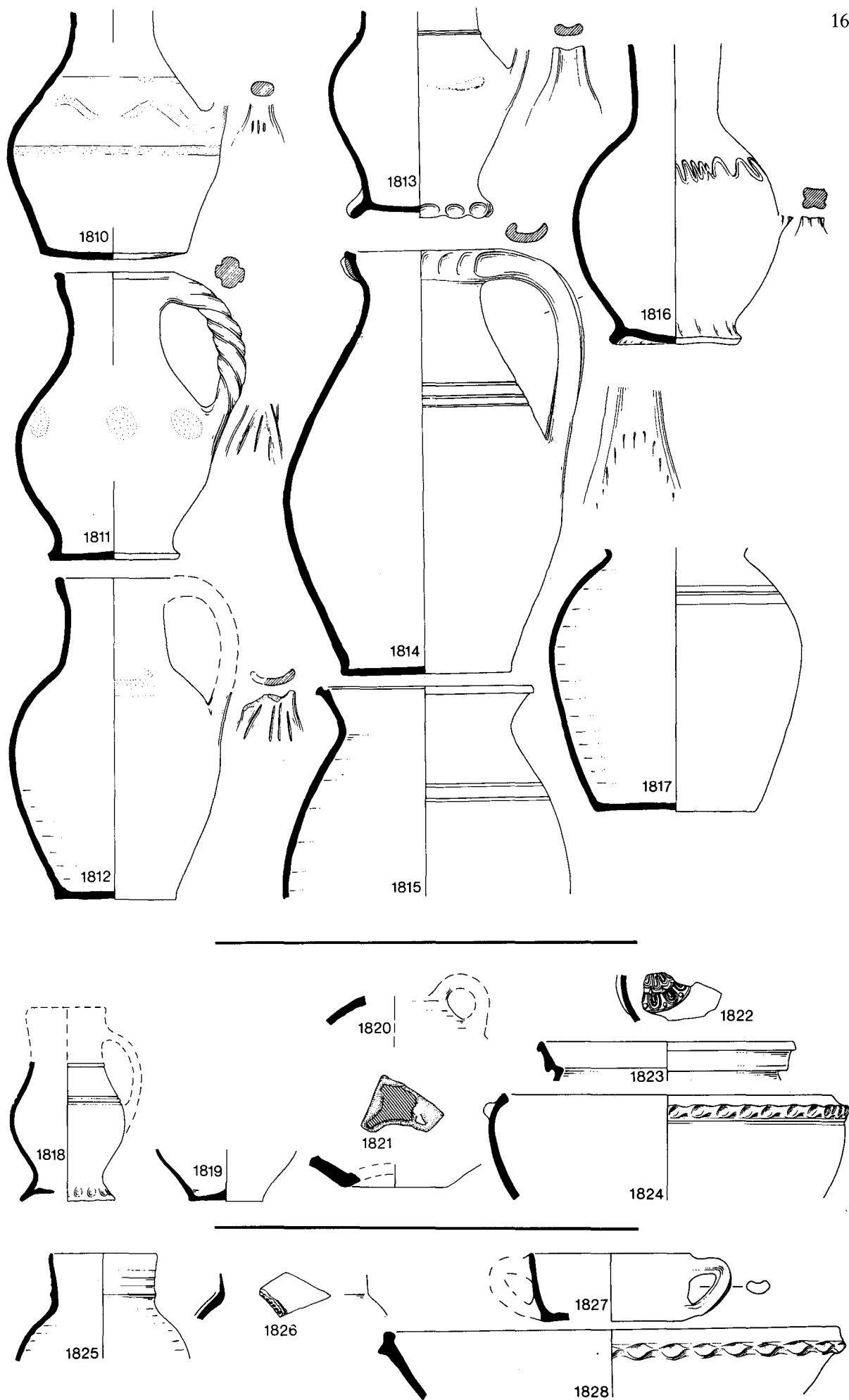

Fig. 79. 16th-century groups from various sites (scale 1:4).



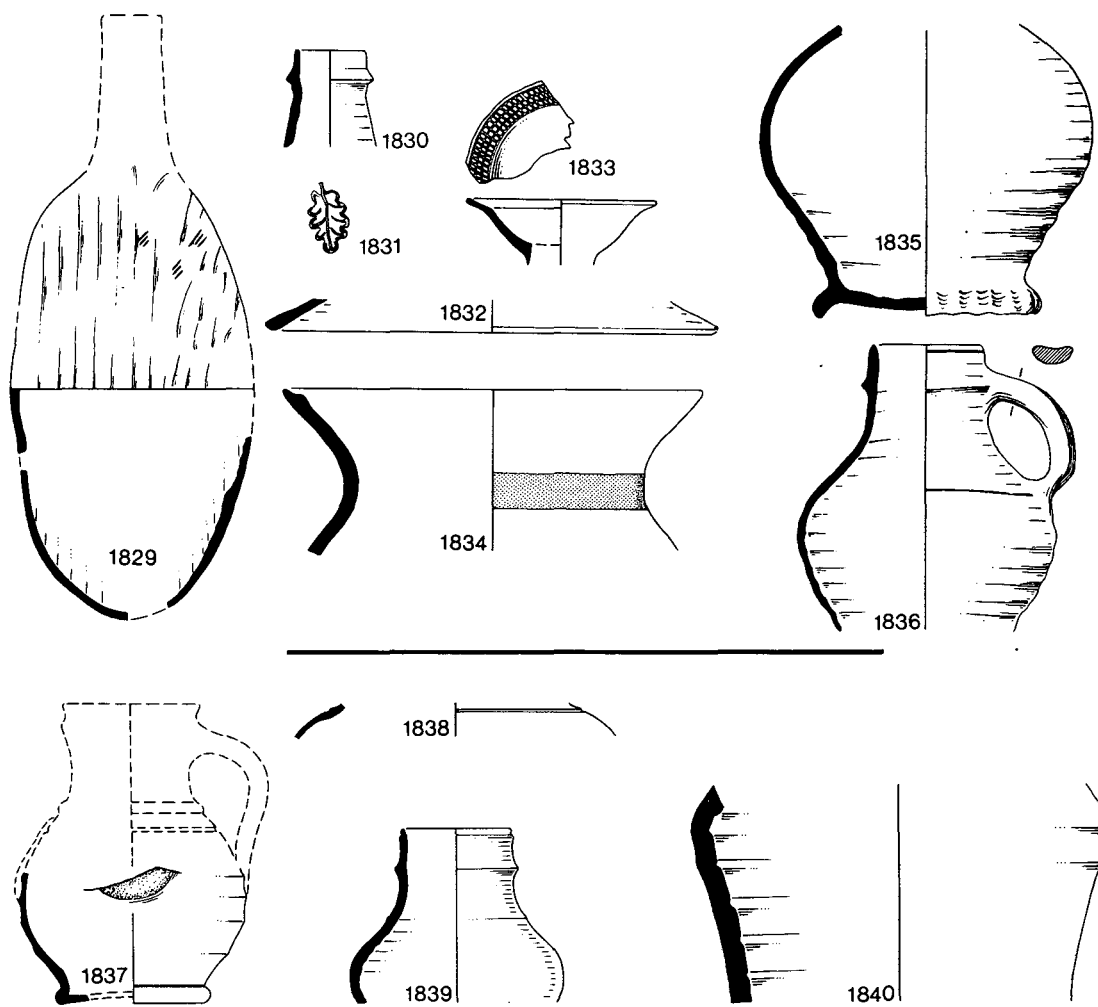

Fig. 80. Early 16th-century groups from Preston Street, Smythen Street and Goldsmith Street (scale 1:4).

- fabric, *int* area of brown lead glaze and white tin glaze, plain tin-glazed back.
- 1822** Green-glazed Beauvais drinking jug with applied rosette medallion.
- 1823** Rim in a plain red fabric with red-brown *ext* glaze, cf. 1961.
- 1824** Coarse Sandy ware, sooted *ext*.  
Date: c. 1500–50.
- MERMAID YARD 727 (Fig. 79)  
Pit group.
- 1825** Raeren mug.
- 1826** Yellow-glazed Beauvais drinking jug with edge of an applied medallion.
- 1827** Sherd from a South Somerset type 10 ?cup. Red-brown *int* and *ext* glaze.
- 1828** South Somerset bowl with wheel-thrown thumbbed strip.  
Date: c. 1500–50.
- PRESTON STREET 384 (Fig. 80)  
Pit group.
- 1829** Sherds of a Martincamp type II flask.
- 1830** Raeren or Aachen stoneware neck, cf. Reineking-von Bock 1971, Nos. 346–7.
- 1831** Applied oak leaf stamp from a Cologne mug, *ill* at half actual size.
- 1832** Unburnished Merida-type sherd, probably a lid.
- 1833** South Somerset sherd, probably from the bowl of a small chafing dish, with incised lines on rim and mid green glaze.
- 1834** Totnes- or St Germans-type ware rim with *ext* painted slip band and *int* glaze.  
Date: c. 1500–50.

#### SMYTHEN STREET (Fig. 80)

Vessels **1835–6** were found in the basement of Rougemont House Museum, Exeter, in an old box marked 'Smythen Street'. They probably come from the excavation of the Exeter Excavations Committee in Smythen Street (Montgomerie-Neilson and Montague 1929–32, 124–8), and were probably found together.

**1835–6** Raeren stonewares.

#### GOLDSMITH STREET 102 (Fig. 80)

Pit group.

*Relations:* Under GS L.7 (1924–9), late 16th-century.

- 1837** Beauvais yellow-glazed drinking jug with scar of an applied medallion.
- 1838** Unburnished Merida-type sherd, a ?costrel.
- 1839** Raeren stoneware.
- 1840** Vessel of uncertain origin, fabric and glaze as 1939–41.

Date: c. 1500–50.

#### QUEEN STREET GROUPS (Fig. 81)

The following sequence of deposits was excavated in 1978: overlying several 12th- and 13th-century pits was an accumulation of garden soil (QS 27). This was cut by a series of parallel trenches (QS 8–15) which in turn were cut by a small pit (QS 3); the latter overlay a small pit (QS 20). A later pit (QS 1) also cut layer QS 27.

QS 27

*Not ill:* Raeren; Coarse Sandy ware (c. 1500+).

QS 8–15

- 1841** Valencian tin-glazed plate sherd. *Ext* concentric lines of lustre. *Int* mid blue painting showing two ranks of leaves, perhaps once alternating with lustre leaves. Very faint traces of lustre lines visible in *int*; c. 1425–75 (J.G. Hurst ident.).

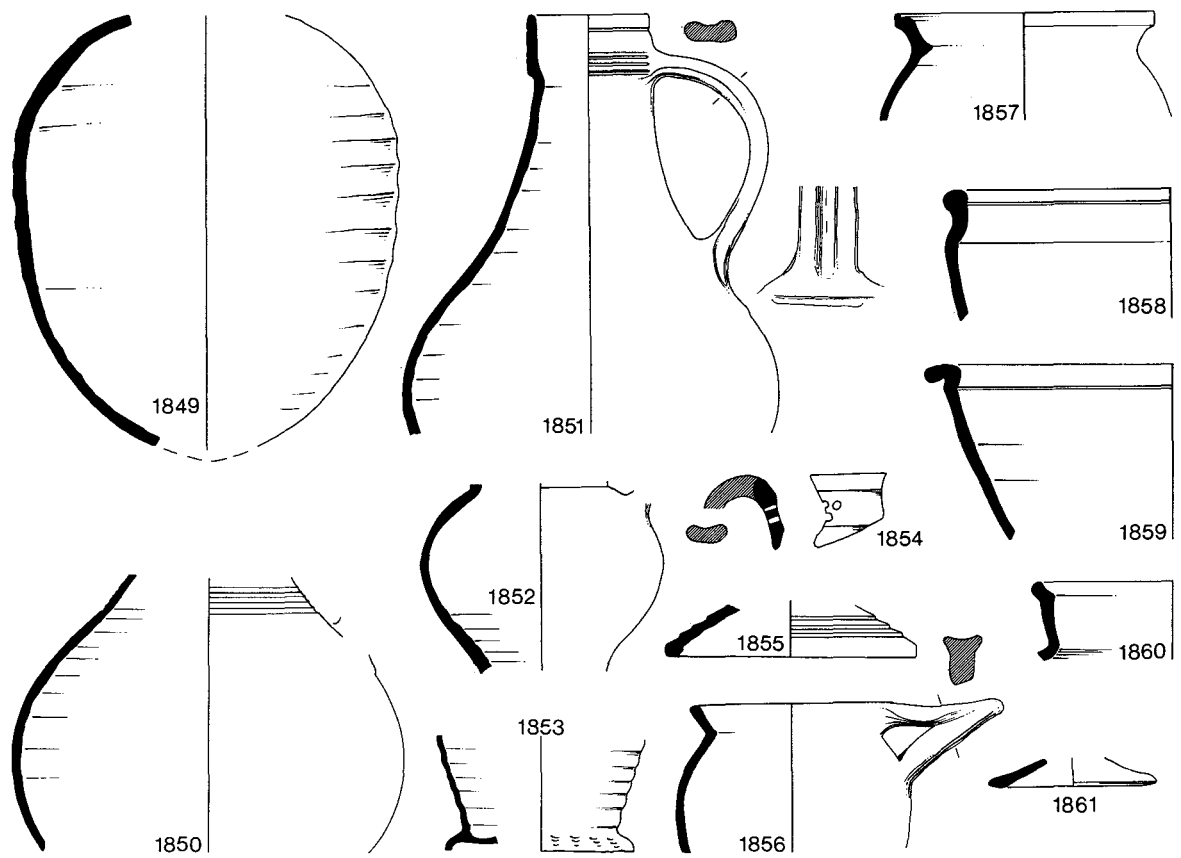
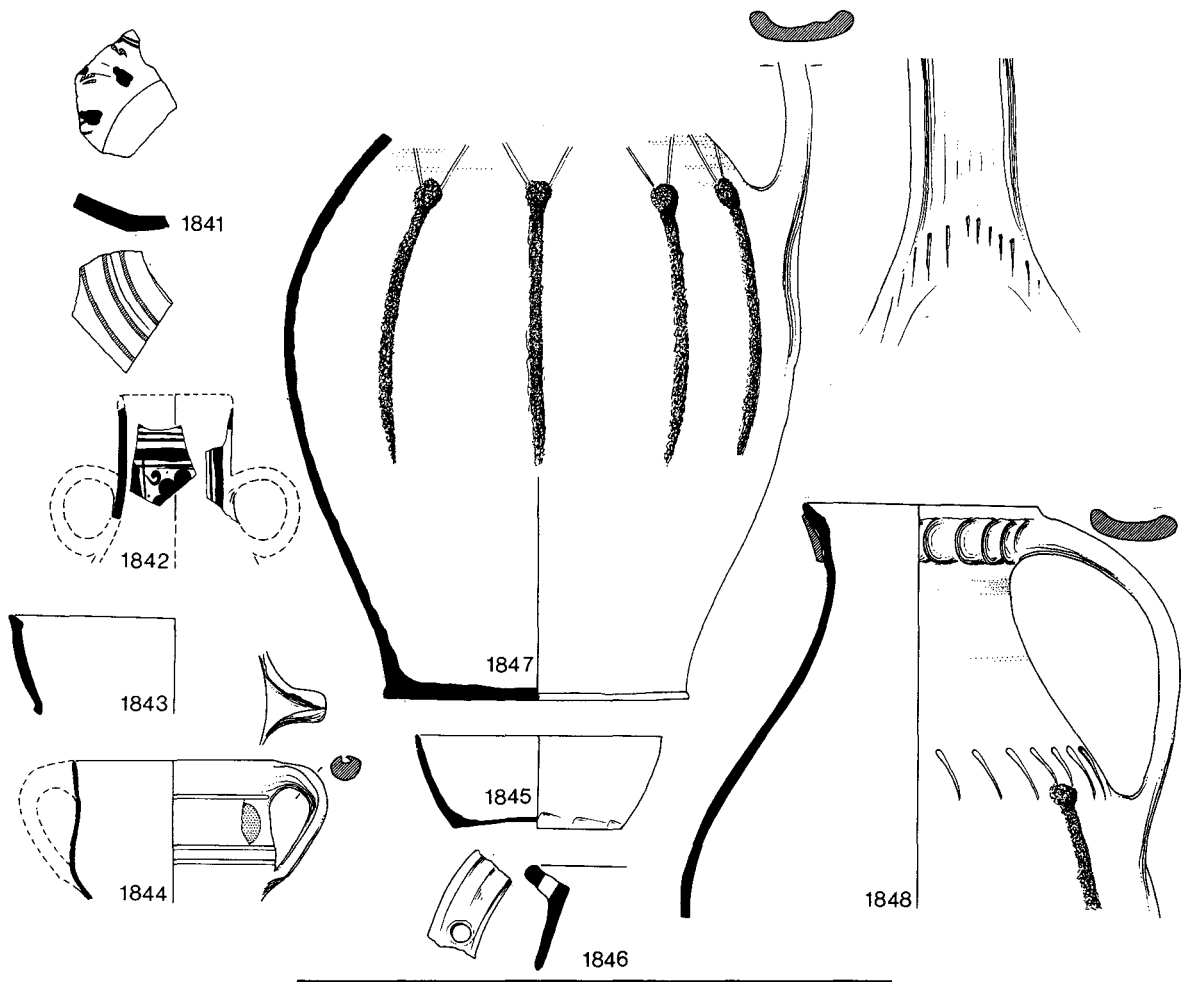

Fig. 81. Sequence of 16th-century groups from Queen Street (scale 1:4).

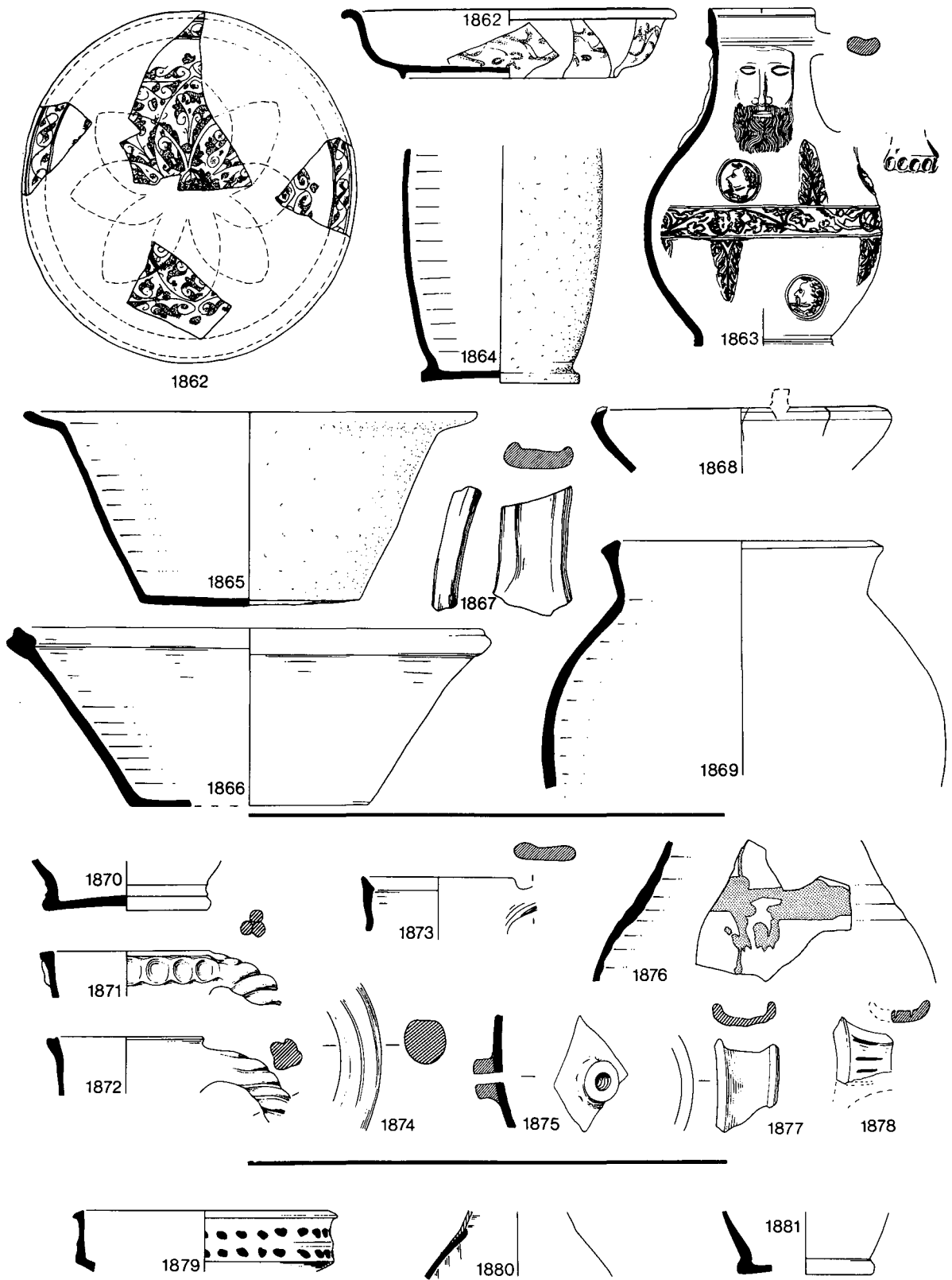

Fig. 82. Groups of c. 1540-80 from Goldsmith Street and Cathedral Close (scale 1:4).

*Not ill:* Martincamp type II; Raeren; Goldsmith Street type 2B. QS 16

*Not ill:* S. Neths. maiolica; Merida-type, *thin-sectioned*, fabric 2 (p. 145); Raeren; Beauvais yellow-glazed jug.

QS 3

**1842** South Netherlands maiolica flower vase sherds, painted blue (perhaps from two vessels).

**1843-4** South Somerset wares. **1843** type 4; **1844** cup with *int* and *ext* light green glaze and applied white clay pad in the style of Cistercian ware cups.

**1845** Small bowl in a rough white sandy fabric with sparse brown stone inclusions. *Int* blotchy yellow glaze with a spot of copper and some iron-bleeding; knife-trimmed unglazed *ext*. Possibly French.

**1846** Unglazed Coarse Sandy ware rim, pierced before firing. Use unknown, but see also **2464**, **2528**.

*Not ill:* Cologne jugs with oak leaves; Beauvais yellow-glazed jug; Goldsmith Street types 3, 4.

QS 20

**1847-8** (Sherds also in QS 16 and 20). Typical South Somerset type 2A jugs with applied iron-rich clay strips over thin slip and shallow scored lines.

*Date:* All the above QS groups contain typical wares of c. 1500-50.

QS 1

*Glass:* G.73.

**1849** Spanish olive jar with *ext* slip.

**1850-3** Stonewares. **1850** Frechen jug; **1851** plain Raeren jug with even bronze-brown *ext* glaze (J. G. Hurst ident.); **1852** Frechen jug; **1853** Raeren.

**1854-6** South Somerset wares. **1854-5** chafing dish sherds; **1856** type 5 skillet, sooted *ext*.

**1857** North Devon type 14 with fragment of slate setter on rim.

**1858-61** Coarse Sandy wares. Rim; type 1D (sooted *ext*); type 4A; lid.

*Not ill:* Beauvais green-glazed jug sherd.

*Date:* c. 1550-1600. The group contains no clay pipe fragments.

#### GOLDSMITH STREET 291 (Fig. 82)

Pit group. No clay pipes.

*Glass:* G.68-70, c. 1550-1600.

**1862** Tuscan maiolica dish. Fine pink-buff fabric, *int* and *ext* thick white tin glaze. Painting in pale blue with a dilute pale blue wash (shown stippled). The type dates to c. 1520-50 (*ex inf.* H. Blake).

**1863** Cologne-Frechen Bellarmine. Applied central frieze with foliage and figures holding medallions. Alternating acanthus leaves and 'portrait' medallions; c. 1525-75 (Hurst 1974a, 281-3).

**1864-5** South Devon micaceous wares.

**1866-8** South Somerset type 1A bowl; handle; and sherd from the bowl of a chafing dish with knife-cut horns.

**1869** Coarse Sandy ware, type 4B. Not sooted.

*Not ill:* Martincamp type I; tall Frechen jug neck as **1989**. Sherds of two Raeren mugs were found in the preliminary cleaning over this pit. They probably are derived from it.

*Date:* c. 1550-80.

#### CATHEDRAL CLOSE 16 (Fig. 82)

The group comes from the fill of a chancel chapel and was associated with a large number of human bones. The chapel was standing in 1538 but seems to have been demolished by c. 1550 (Rose-Troup 1923, 36-7).

**1870** Stoneware jug base with a light grey fabric and dark brown iron wash over most of *ext*. Light grey glaze over body. Probably Cologne-Frechen.

**1871-89** South Somerset jugs and (**1875**) cistern.

*Not ill:* 2 Cologne-Frechen; 6 Raeren.

*Date:* Mid 16th-century.

#### GOLDSMITH STREET L.8-9 (Fig. 82)

Group from a layer of garden soil.

*Relations:* Cut by GS 33-8 (below).

**1879** Valencian tin-glazed sherd (Hurst 1977a). *Ext* pale blue blobs. No lustre visible.

**1880** Martincamp type I flask.

**1881** Cologne-Frechen stoneware jug base.

*Not ill:* Beauvais yellow-glazed jug; Martincamp type II; Raeren.

*Date:* The group contains sherds of plain Frechen drinking jugs but is under GS 33-8; c. 1550-80.

#### GOLDSMITH STREET 33-8 (Fig. 83)

Group from a row of parallel trenches adjacent to Pancras Lane, believed to have been cultivation trenches (Collis 1972, 13-14).

*Dating evidence:* The tile **1882** dated 1556 provides a *terminus post quem* for the group. No trench contained clay pipe fragments. Frechen sherds were present in all of them, confirming that they were filled after c. 1550. If **E.15** is not residual, the group dates to 1556-c. 1565. Most identifiable vessels are represented by only one or two sherds.

*Coins and jettons:* **E.7** (GS 38) 13th-century, residual. **E.15** (GS 38) 1544-c. 1565. **J.9** (GS 33) early 16th-century, very worn. **J.10** (GS 33) mid or late 16th-century, rather worn. **J.14** (GS 38) late 16th-century, worn.

*Glass:* G.72, (GS 37) late 16th-century.

*Imports*

**1882** Dutch tile bearing the date 1556. Hard brick-red fabric with sparse rounded sandy inclusions, deeply inlaid white slip; nail holes at corners. Glazed dark green-brown over body, mid green over slip. The tile has been used: mortar adheres to its back. This is a Netherlands type; tiles from this stamp are known, for example, from Gouda (de Jonge 1971, Fig. 2b). Two further examples of the same design have been found in Exeter, the first recovered during building observation at Paul Street, the second, also unstratified, from the area excavated at Rack Street in 1977. The type is fully discussed by Horton (1981, 235-46).

**1883** Sherd of a Valencian lustreware dish (Hurst 1977a). One horizontal lustre line painted on back. On front, fragments of pale blue painted leaves, traces of lustre pattern too faint to be drawn. Pre-1475 style (*ex inf.* J. G. Hurst).

**1884** Unglazed unburnished Merida-type sherd.

**1885** Unglazed globular Spanish olive jar with *ext* slip.

**1886** Unburnished Merida-type sherd.

**1887-8** Beauvais sgraffito wares. **1887** Albarello with single brown slip, incised lines glazed yellow, *int* pale yellow glaze; **1888** plate with fragment of border letter with double slips and patches of copper green.

**1889** Martincamp type I flask.

**1890** Cologne-Frechen jug with acanthus leaf and medallion.

**1891** Sherd of a tall mug with moulded decoration showing peasants in roundels with vine leaves and grapes between. Light grey-buff stoneware, *int* glossy grey glaze, *ext* mottled rather glossy grey-brown. Probably Cologne.

**1892-5** Frechen stoneware jugs.

*Not ill:* 8 Raeren vessels.

#### Micaceous and North Devon wares

**1896** Jug, South Devon micaceous ware.

**1897-1901** North Devon gravel-free sherds with calcareous inclusions, **1897-8** white-painted.

**1902** Unglazed North Devon gravel-tempered sherd from a vessel of uncertain form.

**1903** St Germans- or Totnes-type white-painted rim.

**1904** South Devon micaceous ware with *int* glaze.

**1905-12** South Somerset 15th/16th-century types (attribution of **1909** rather uncertain).

**1913-14** Coarse Sandy wares.

**1915-20** Plain brick-red earthenwares of uncertain origin (? South Somerset).

#### GOLDSMITH STREET L.7 (Fig. 84)

Layer, possibly a garden soil.

*Relations:* Over GS 37 and GS 38 (above); after 1556. No firm relation was established with GS L.16-18 (below) but they may be the same deposit. The pottery from this layer is very similar to that of GS 33-8 which may have been deposited at the same time. There are no clay pipe fragments.

*Coin:* F.6, possibly late 17th-century *liard* (intrusive).

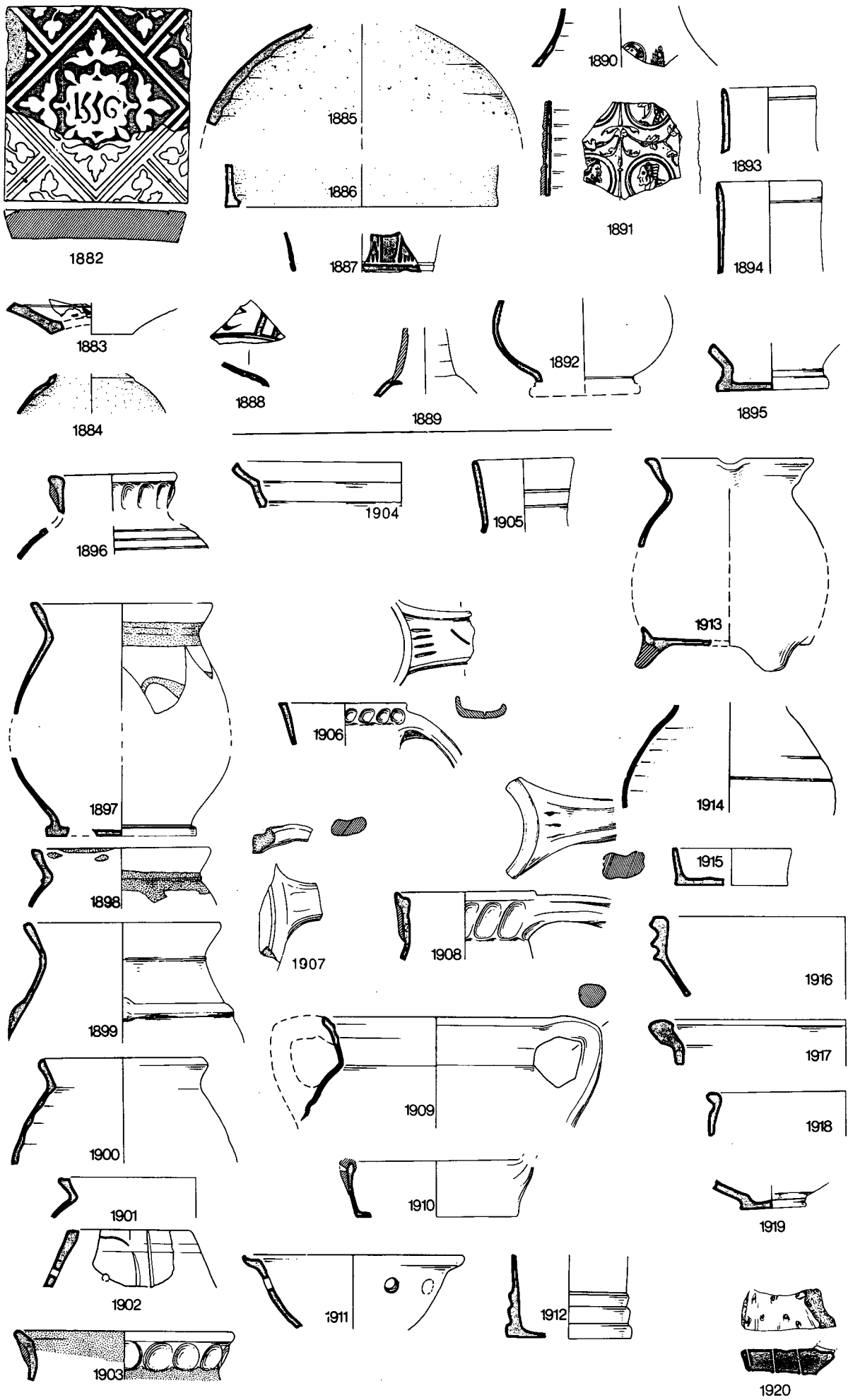

Fig. 83. Goldsmith Street 33-8, 1556-c. 1565 (scale 1:4).

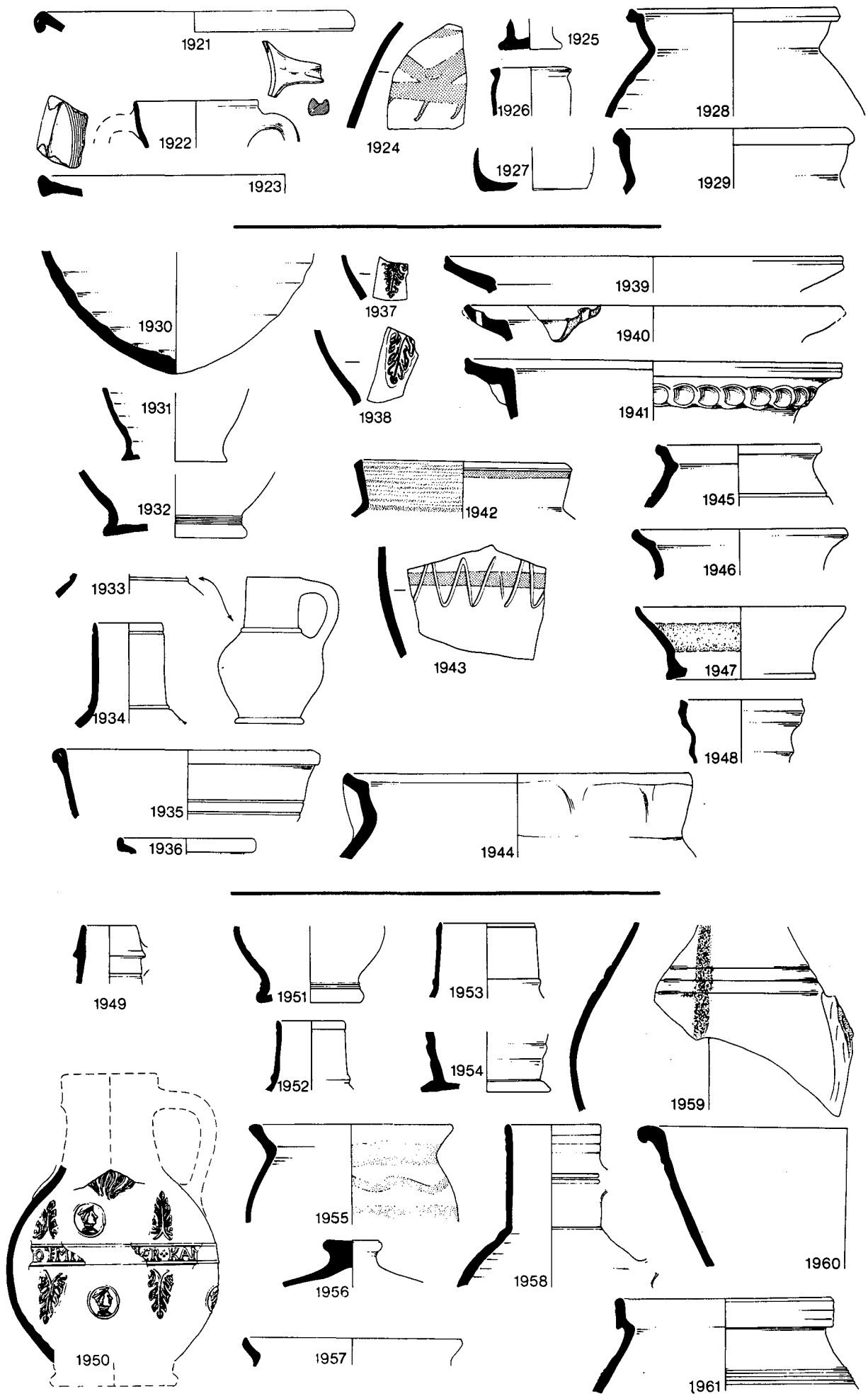

Fig. 84. Late 16th-century groups from Goldsmith Street (scale 1:4).

*Imports*

- 1921** Unburnished Merida-type bowl sherd.  
**1922** Sherd from a cup with a fine grey-white fabric and mid green glaze and yellowish spots. Possibly imported, possibly Surrey-Hampshire.  
**1923** Sherd of a Beauvais plate without slip. Rich mid green glaze over combing on upper surface.

*Not ill:* 4 Raeren; 2 Cologne-Frechen; Beauvais green-glazed jug; Martincamp type I.

*Local*

- 1924** North Devon white-painted sherd.  
**1925-7** ?South Somerset wares with *ext* glaze.  
**1928-9** Coarse Sandy wares, type 4A.

## GOLDSMITH STREET L.16-18 (Fig. 84)

Single deposit, possibly a garden soil, excavated in three trowellings. The group is unfortunately contaminated; six clay pipe fragments and at least 10 later sherds are present.

*Imports*

- 1930** Globular Spanish olive jar sherd without slip or glaze.  
**1931** Beauvais stoneware base.  
**1932** Frechen stoneware base.  
**1933** Neck sherd from a jug. Buff fabric, *int* white tin glaze, *ext* blue tin glaze. This is only a scrap and too small for firm identification but is perhaps from a Malling jug, with the collar at the base of the neck copying Frechen stoneware (sketch of complete example to right). A South Netherlands source is also possible. The problems of attribution of a very similar fragment from Gorey Castle, Jersey, are discussed by Hurst (1977c, 81, No. 127).  
**1934** Frechen stoneware jug.  
**1935** Surrey-Hampshire white ware with pale yellow *int* glaze.  
**1936** Albarello rim. Fine sandy white fabric, rich *int* green glaze.  
**1937-8** Sherds from Cologne-Frechen stoneware jugs with applied acanthus leaves.  
**1939-41** Sherds with soft rather granular fabrics without visible inclusions. Grey core, pink-buff zones under a mottled thick mid to dark green *int* glaze below the rim. Origin uncertain, possibly Mediterranean. See also 1840.

*Not ill:* Beauvais yellow-glazed jug sherd; 7+ Raeren vessels; 25+ plain Frechen vessels; Low Countries redware bowl sherd with a 'pulled' foot, *int* slip, line sgraffito; Martincamp type II.

*Local wares*

- 1942-3** Unglazed Totnes-type or St Germans-type ware.  
**1944** South Somerset rim with applied strip glazed red-brown.  
**1945** North Devon gravel-free fabric with calcareous inclusions, usual *int* glaze.  
**1946** Coarse micaceous bowl sherd, origin uncertain.  
**1947-8** Possible South Somerset wares.

*Not ill:* Coarse Sandy types 1A, 1C, 1E/F, 3, 4A, 4B, 7.

*Date:* See below (GS L.24). Both the imports and local wares in this group are almost identical to those in GS 33-8. Sherds from some of the more distinctive vessels (e.g. 1933) are present in both groups and they may well have been deposited at the same time. A date of c. 1550-80 is probable.

## GOLDSMITH STREET L.24 (Fig. 84)

Layer of garden soil. No stratigraphic relation was observed between this layer and GS L.16-18 but they may well be the same deposit. There are at least 20 intrusive sherds but most (401 sherds) are of 16th-century types.

*Imports*

- 1949** Raeren stoneware.  
**1950** Cologne-Frechen stoneware jug with acanthus leaves, peasant busts in medallions and central band inscribed . . . ] OT:MI [ . . . . . ] VER:KAN [ . . . Type of c. 1550-80 (Hurst 1974a).  
**1951-3** Frechen stoneware jugs.

*Not ill:* 7+ Raeren; 1 Langerwehe; 4+ plain Frechen jugs; Martincamp type II; Beauvais yellow-glazed sherd; Merida-type with *int* clear green-brown glaze, *ext* slip and bright copper-green glaze; 'Columbia plain' ware.

*Local wares*

- 1954** Green-glazed South Somerset cup base, type 6B or 6C.  
**1955** North Devon gravel-free ?chamber pot or jar.  
**1956** Unglazed rather sandy brick-red lid. Origin uncertain, perhaps South Somerset.  
**1957** North Devon gravel-free ware, form 14 with calcareous inclusions.  
**1958-9** South Somerset jugs with *ext* green-brown glaze.  
**1960** Coarse Sandy ware bowl, type 1C.  
**1961** Cooking pot in a hard red fabric with a red-brown *int* glaze. Origin uncertain.

*Not ill:* Coarse Sandy types 3, 4B.

*Date:* GS L.7, L.16-18, and L.24 may well have comprised a single deposit immediately overlying GS 33-8. All these groups are very similar in character, probably with many sherds from the same vessels, although few joins have been found. The large number of Raeren vessels and the Beauvais sherds, which the documentary evidence suggests were not imported in any quantity after c. 1560, favour a date early in the period 1550-1600. This is also believed to be the date of the Cologne-Frechen acanthus leaf jugs (Hurst 1974a). Support for a date in the third quarter of the century is provided by a large group of pottery from Narrow Quay, Bristol, dated on the evidence of associated leather and other finds to c. 1580-90 (*ex inf.* M. Ponsford). The Narrow Quay group includes many of the South Somerset sgraffito-decorated and slip-coated wares which are well-known types in the 17th century. None of these types is present amongst c. 1400 sherds in the Goldsmith Street groups. Narrow Quay contains little or no Raeren but a large number of Frechen wares. The differences between these two very substantial groups suggest that the Exeter groups are the earlier, c. 1550-80.

## PRESTON STREET 343-51 (Fig. 85)

The following sequence comes from a series of dumps (PS 343-51) over a pit filled with horse dung (PS 348). There are several joining sherds between these deposits, and they may well be contemporary. No features contain clay pipe fragments, whilst the Frechen sherds in PS 348 indicate a date after c. 1550 for the series. All these groups date to c. 1550-1600.

*PS 343*

- 1962** South Netherlands maiolica base with *ext* painting in blue, with a patch of orange.  
**1963** Rim of an albarello with a fine white fabric with *int* and *ext* mid green glaze. North French, possibly Beauvais.

**1964** Raeren stoneware jug neck, cf. 1851.

*PS 347* (under 343, over 349)

**1965-7** South Somerset cup, jug and gritty ware rim.

*PS 349* (under 347)

**1968** Tin-glazed sherd. Fine, rather granular pink fabric without visible inclusions. *Int* cream-white tin glaze, *ext* white tin glaze with splashes of mauve and mid blue. Probably a Malling jug.

**1969** South Somerset vessel with *ext* glaze; possibly an ointment pot.

**1970** Coarse Sandy ware, type 3 tripod pipkin.

**1971** Type 3 tripod pipkin in a coarse sandy fabric but with fine calcareous and quartzite inclusions erupting through the surface.

**1972** Coarse Sandy ware, ?type 2 jug.

**1973-7** Coarse Sandy wares. **1973-6** type 7 chamber pots; **1977** type 1A bowl.

*PS 351* (under 349)

**1978** Frechen stoneware jug.

**1979** Coarse Sandy ware bowl.

*PS 348* (under 350)

**1980** Frechen stoneware jug.

**1981** South Somerset sherd with *ext* combing and dark green glaze, perhaps from the base of a candlestick or, if inverted, from the bowl of a chafing dish.

**1982** St Germans-type ware with bands of *ext* white slip.

**1983** Low Countries redware sgraffito-decorated plate. Hard brick-red fabric with fine white inclusions. *Int* slip with spots of copper-green. *Int* glaze, dark green-brown over sgraffito, pale yellow over slip.

*Not ill:* Beauvais sgraffito sherd with double slips; Raeren.

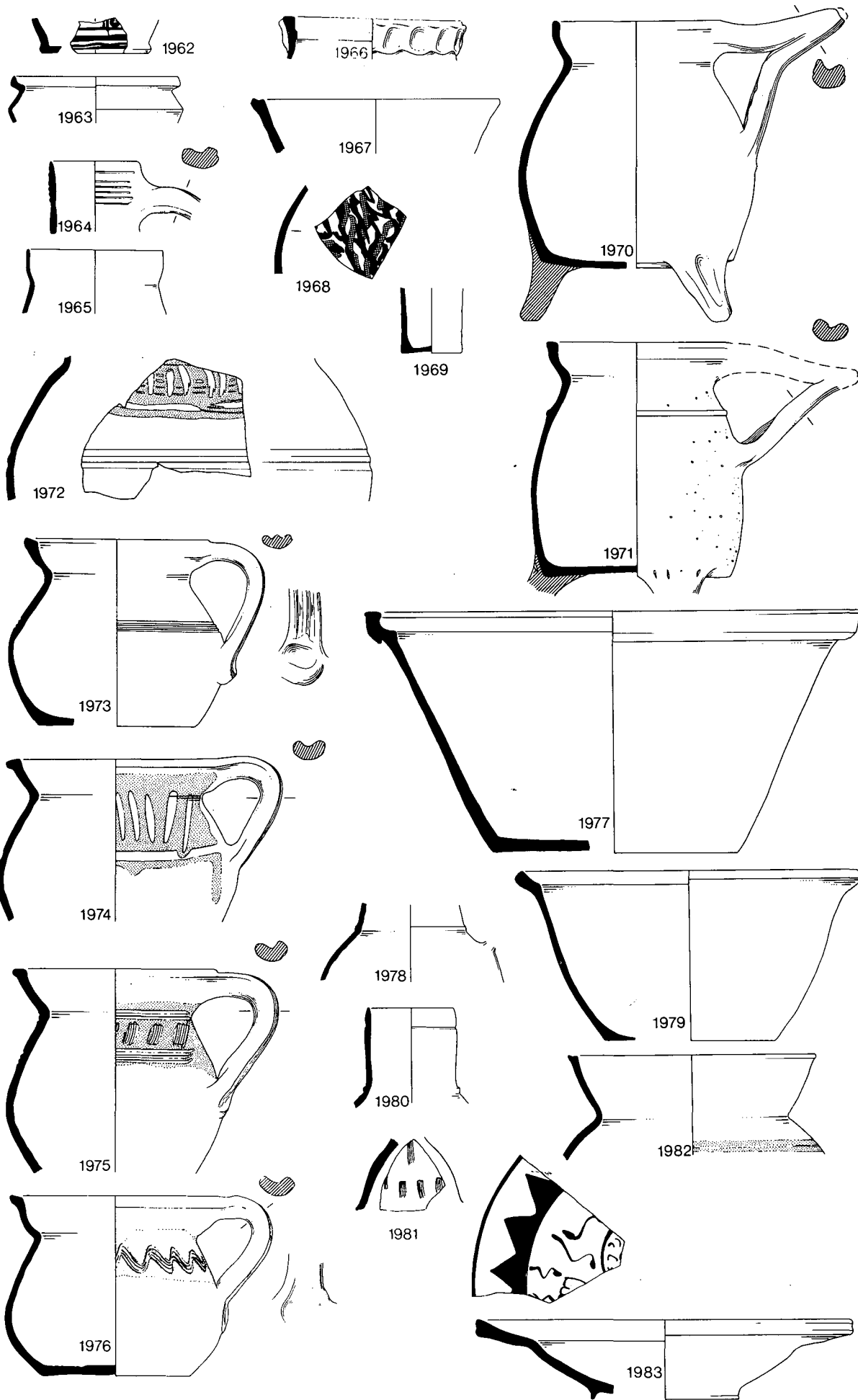

Fig. 85. Sequence of late 16th-century groups from Preston Street (scale 1:4).



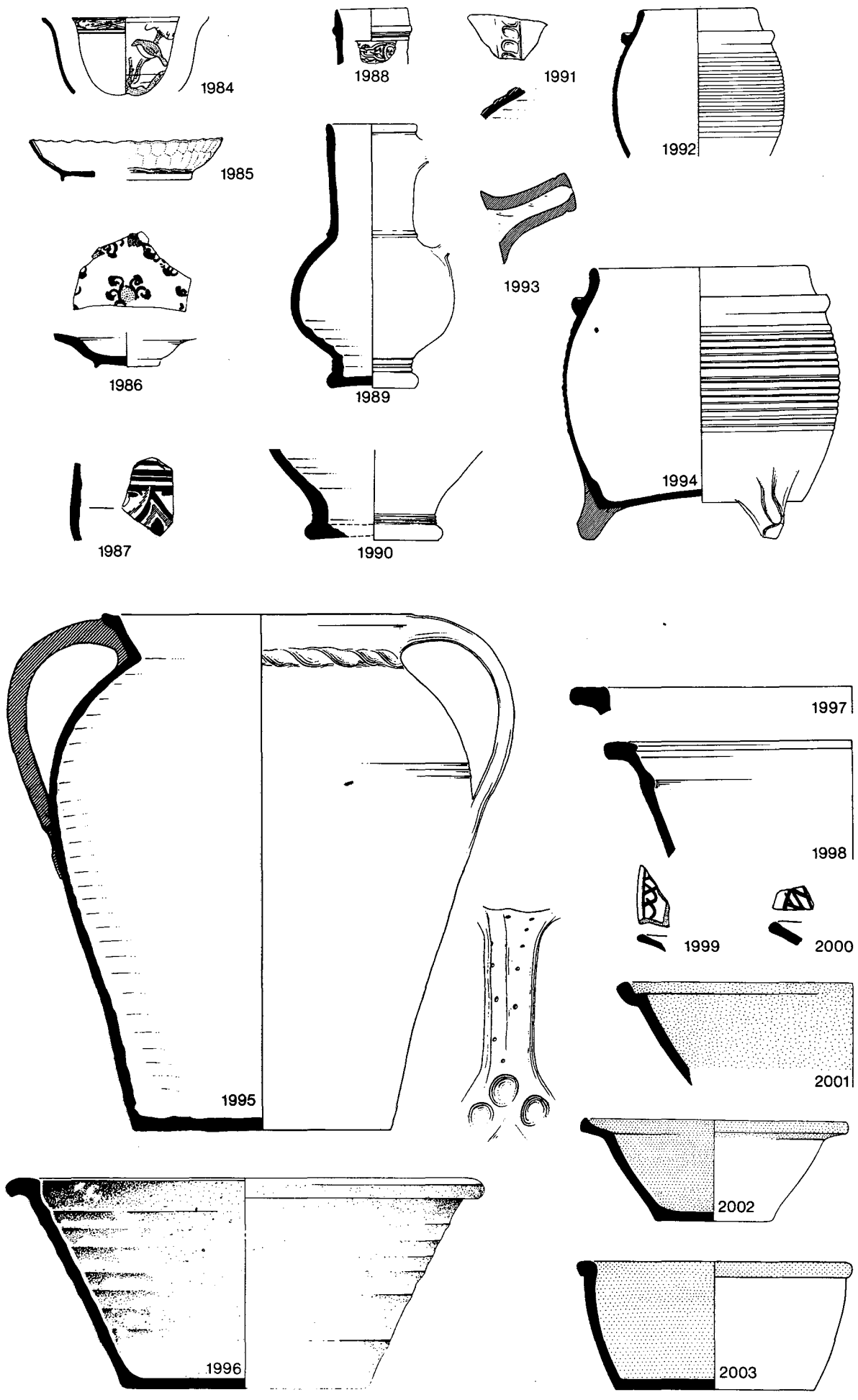

Fig. 86. Queen Street 314, c. 1600 (scale 1:4).

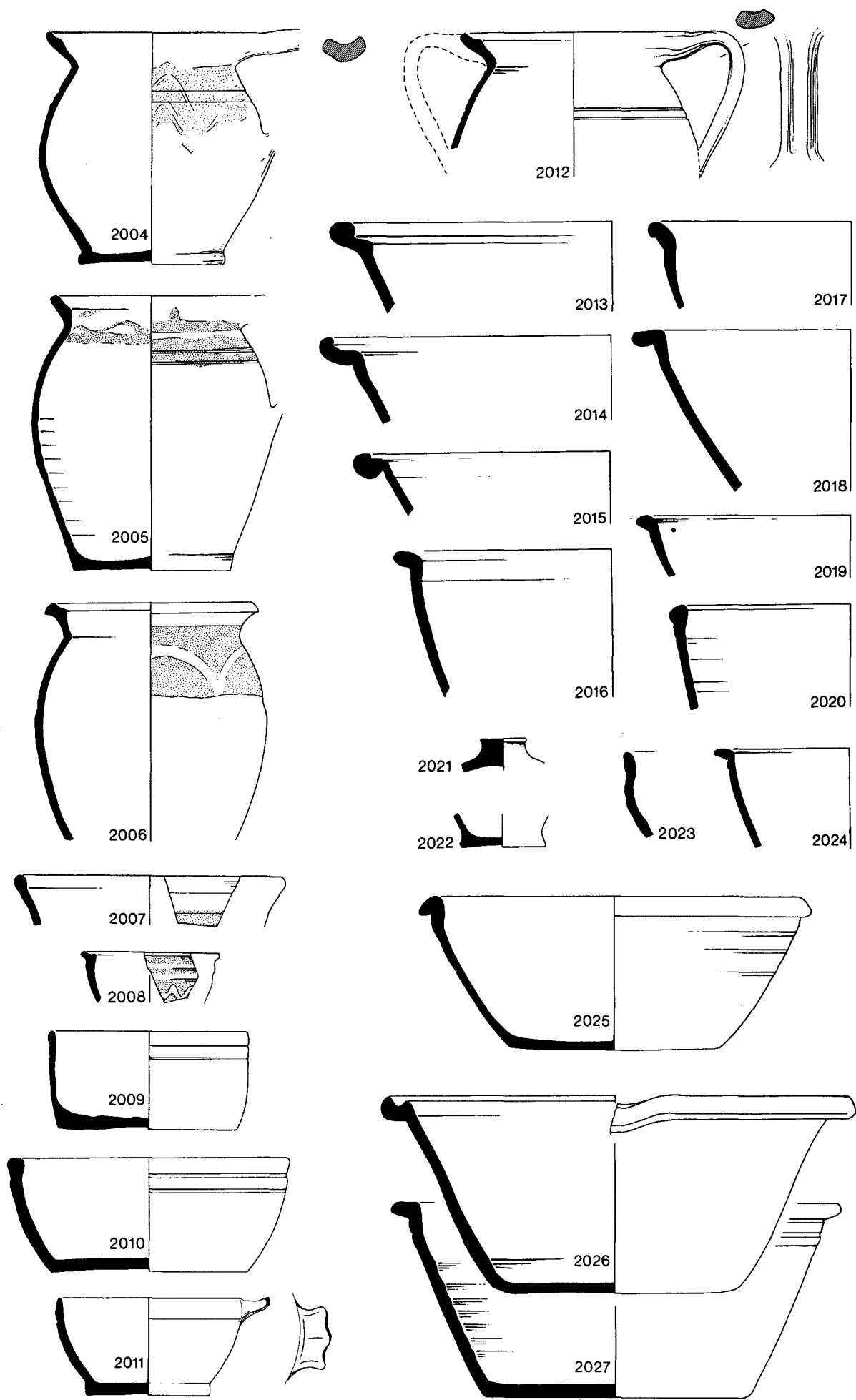

Fig. 87. Queen Street 314, c. 1600 (scale 1:4).

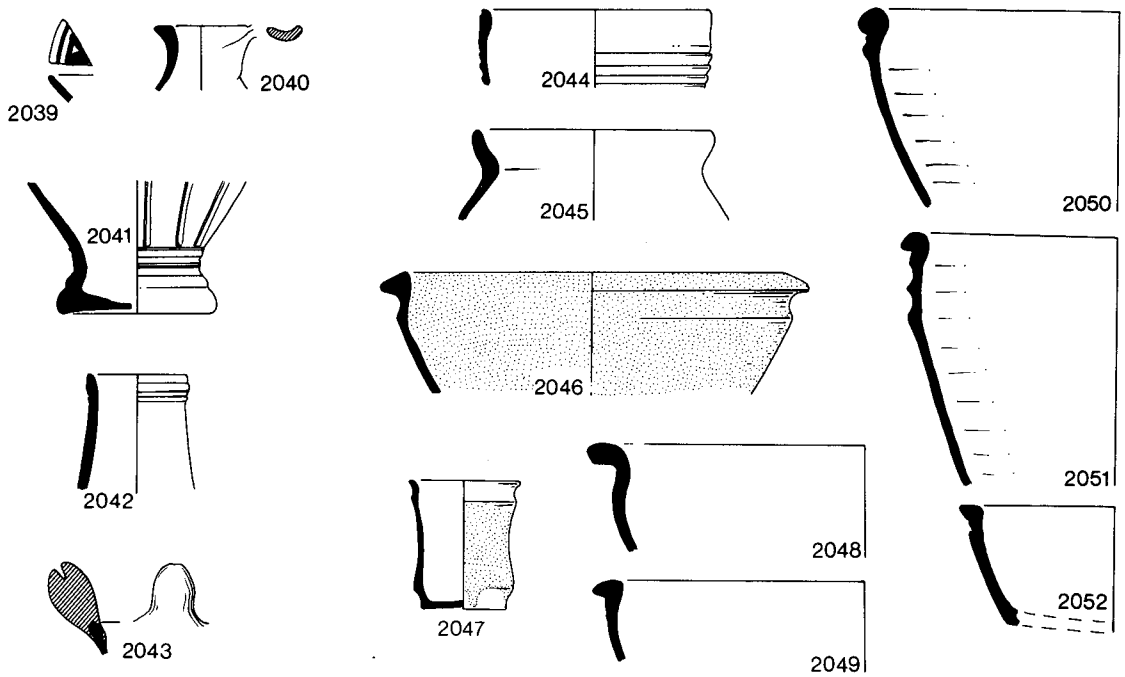
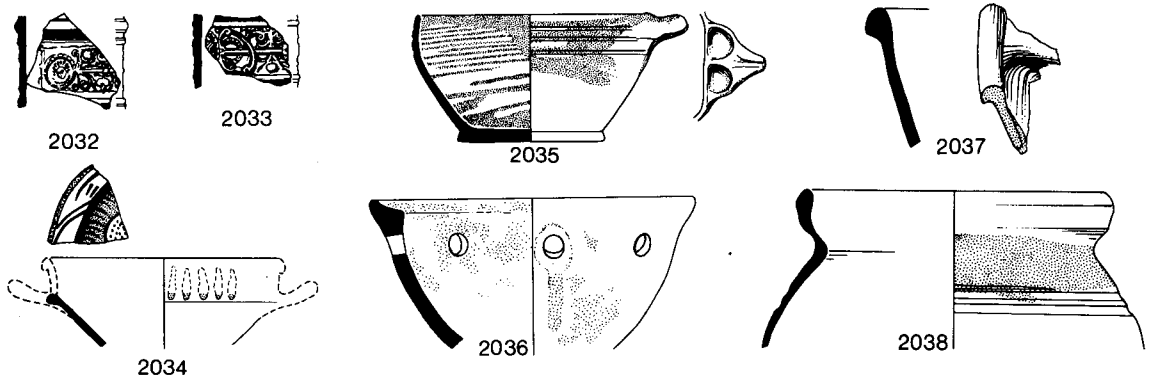
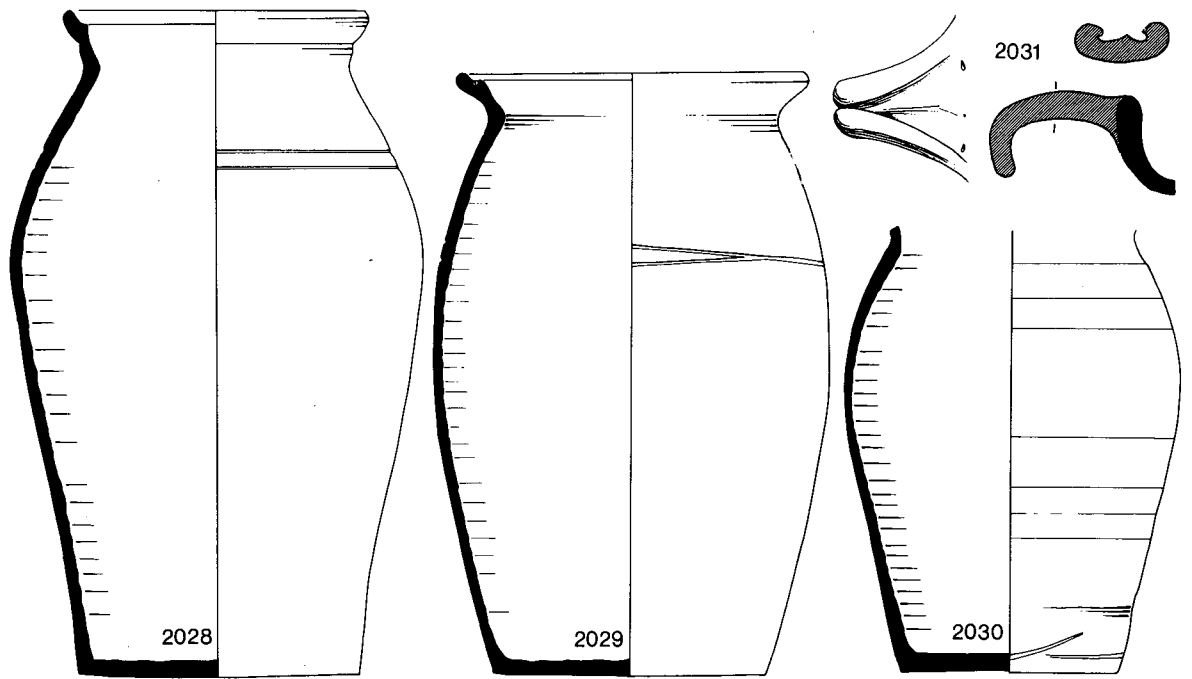

Fig. 88. Queen Street 314, *c.* 1600; Rack Street 794, *c.* 1600–25; Good Shepherd Hospital 20, *c.* 1610–40 (scale 1:4).

## QUEEN STREET 314 (Figs. 86–8)

Pit group.

Clay pipe: CP.109, c. 1600.

Glass: G.74–86, all of c. 1600.

Imports

1984–5 Sherds from a small deep Chinese porcelain bowl (1984) and saucer-dish (1985) painted in underglaze blue, the latter with a border of two ranks of moulded petals and a sanded foot-ring. Wan Li, c. 1590–1610 (Pl.1).

1986 Italian maiolica dish with *int* and *ext* white tin glaze. *Int* painted with floral pattern in yellow, red-brown and dark blue. Probably Montelupo, late 16th-century (J. G. Hurst ident.).

1987 Sherd of a tin-glazed drug jar painted blue and red-brown. ?Dutch.

1988 Westerwald jug sherd with blue *int*; cf. Reineking-von Bock 1971, Nos. 427–42, c. 1600.

1989–91 Frechen stonewares, 1991 from the base of a handle with thumb-impressions.

1992–4 Surrey-Hampshire tripod pipkins. 1992, 1994 with rich *int* green glaze, both sooted *ext*; 1993 handle with yellow glaze.

*Not ill:* Maiolica sherds with all-over thick yellow *int* and *ext* glaze, ?Italian; scrap of a Raeren jug like 1988 with blue *ext*, brown *int*, end of the 16th century.

English wares

1995–8 North Devon gravel-tempered wares. 1995 gravel-free body, gravel-tempered handles pierced with nail holes, green *int* glaze; 1996–8 type 3A bowls, heavily sooted *ext*.

1999–2012 South Somerset 17th-century types. 1999–2000 sherds from plates with *int* slip, glazed yellow, and crude line sgraffito, glazed red-brown; 2001–3 vessels with *int* slip, glazed yellow, and unglazed *ext*, 2002 with a splash of copper-green over slip; 2004–12 vessels with *ext* unglazed light red surfaces and *int* red-brown or dark orange-brown glaze speckled with iron-bleeding. All have unglazed bands of *ext* slip with finger-dragged or sgraffito decoration. None is sooted. 2004–6 chamber pots; 2007–8 rims, vessel form uncertain; 2009–10 complete bowls, type 2E; 2011 complete porringer, type 13A; 2012 ?two-handled vessel.

2013–31 Coarse Sandy wares. 2013–20 bowls; 2021 unglazed lid; 2022 ?cup base; 2023 rim, orange *int* glaze, probably South Somerset; 2024–7 bowls, 2025 type 1D, 2026 type 1A; 2027 type 1C; 2028–30 type 10 jars; 2031 handle of a rectangular pan, sooted *ext*.

*Date:* The porcelain, stoneware, clay pipes and glass are consistent with a date of c. 1600.

## RACK STREET 794 (Fig. 88)

Group from a layer of garden soil.

2032–3 Necks of Westerwald jugs with blue *int*; cf. Reineking-von Bock 1971, Nos. 476–83, c. 1600.

2034 North Holland slipware sherd with combed sgraffito lines through slip, probably part of a floral design; cf. Hurst *et al.* 1975, 54, No. 23. Small bowls of this type belong to the first quarter of the 17th century (*ibid.*, 51).

2035–8 South Somerset 17th-century wares. 2035 type 13A porringer with patchy slip glazed yellow; 2036 bowl of a chafing dish; 2037 ?condiment dish; 2038 ?jar with *int* green glaze.

*Date:* Sherds 2032–4 all favour a date of c. 1600–25.

## GOOD SHEPHERD HOSPITAL 20 (Fig. 88)

Pit group.

Clay pipes: CP.105–8, c. 1610–40.

Imports

2039 Tin-glazed dish scrap with a plain white back.

2040 Plain tin-glazed bottle neck with *int* and *ext* glaze. Top of rim heavily abraded, perhaps from use.

2041 Raeren jug base, cf. Reineking-von Bock 1971, Nos. 360–4; c. 1570–1610.

2042 Frechen stoneware jug.

2043 Knob of a Saintonge type C.VI chafing dish (Hurst 1974b, 245). Mid green glaze, fired adjacent to a

polychrome vessel: red slip adheres to the firing scar.

2044 Surrey-Hampshire yellow-glazed porringer (cf. Moorhouse 1970, Fig. 12, Nos. 53–61).

Local

2045 North Devon gravel-free fabric with *int* glaze.

2046–8 South Somerset wares. 2046 with *int* and *ext* slip; 2047 drug jar with *ext* glazed slip; 2048 plain bowl.

2049–52 Coarse Sandy ware bowls with red-brown *int* glazes.

*Not ill:* Totnes-type sherd; Coarse Sandy types 1A, 1C, 1E, 1F, 10 (2); S. Somerset 17th-century types 2E, 6.

*Date:* c. 1610–40.

## PRESTON STREET 207 (Fig. 89)

Pit group.

2053 Frechen stoneware jug.

2054–7 South Somerset wares. 2054–5 dishes with deeply scored sgraffito lines through slip; copper in slip gives pale green glaze; 2056 chafing dish bowl; 2057 bucket-handled pot.

2058 Coarse Sandy ware, type 1D.

*Date:* The group contains no clay pipe fragments. Late 16th- or early 17th-century.

## TRICHAY STREET 103 (Fig. 89)

Group from a layer.

2059 Tin-glazed porringer with *ext* plain white glaze and *int* blue painting. Probably Dutch, early 17th-century cf. Mynard 1969, Fig. 10, No. 5.

2060 Unglazed Spanish olive jar.

2061–3 South Somerset wares. 2061–2 yellow-glazed slipwares, 2062 with combed sgraffito decoration; 2063 cup with *int* and *ext* green-brown glaze.

*Date:* Early 17th-century.

## NATIONAL WESTMINSTER BANK 8 (Fig. 89)

Pit group.

2064 Montelupo tin-glazed dish with floral pattern in green, orange-yellow, pale blue and black. *Ext* mauve horizontal bands; cf. several similar dishes from Plymouth (Gaskell Brown 1979, Fig. 26, No. 197; Broady 1979, Fig. 43, No. 533); for the style see *ibid.*, Fig. 43, No. 529; Barton 1964, Fig. 66, No. 3.

2065 Dutch or English tin-glazed sherd with dull blue painting, lead-glazed *int*. Early 17th-century.

2066 Coarse Sandy ware, type 4B.

*Date:* The group contains clay pipe stems and probably once included 2816. The Coarse Sandy ware confirms a date before c. 1650; early 17th-century.

## VALIANT SOLDIER 63 (Fig. 90)

Pit group.

*Relations:* Cut by VS 61 (below).

Clay pipe: Type 4G, c. 1620–40.

2067 North Holland slipware bowl with part of pine pattern (Hurst *et al.* 1975, type 3, No. 20). Under-side sooted.

2068–79 South Somerset wares. 2068–70 and 2072 with yellow-glazed slip and line sgraffito; 2071 ointment pot with plain yellow-glazed slip; 2073–9 plain coarsewares.

*Date:* c. 1620–50.

## VALIANT SOLDIER 61 (Fig. 90)

Pit group.

*Relations:* Cut VS 63 (above).

Clay pipe: Type 4B, c. 1640–60.

2080 Westerwald stoneware jug as 2121, c. 1600–20.

2081 Base of a jug. Fine white fabric, *ext* mid green glaze. Surrey-Hampshire or French. Sooted base.

2082 Sherd of Cologne encrusted ware. Fine white fabric, *int* clear yellow glaze, *ext* quartz and mid green glaze.

2083–4 North Devon type 14 jars.

2085–99 South Somerset wares. 2085 base as 2068–70; 2086 chafing dish base; 2087 yellow-glazed slipware candlestick sherd; 2088–92 coarseware jugs; 2093

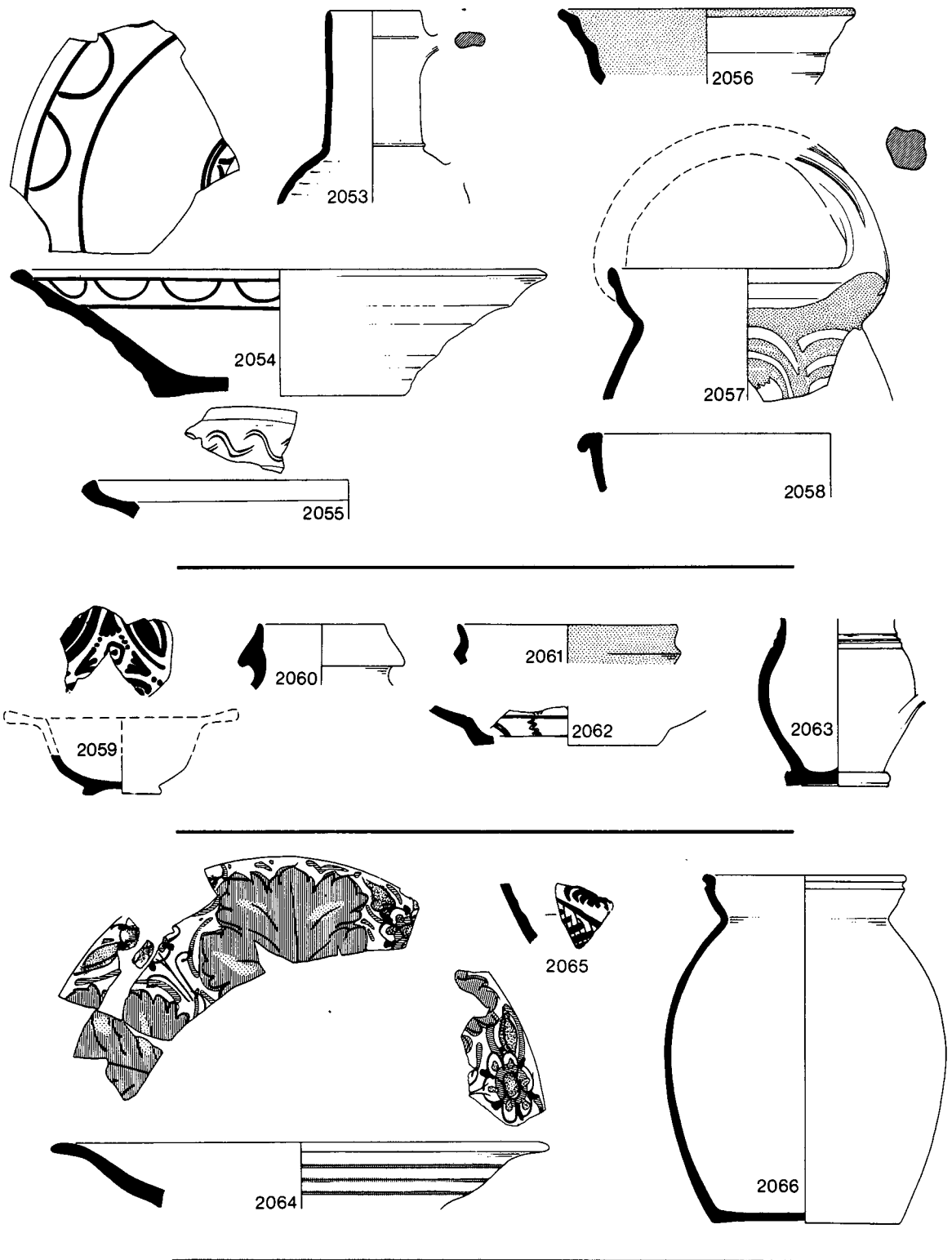

Fig. 89. Late 16th- and early 17th-century groups from Preston Street, Trichay Street and the National Westminster Bank (scale 1:4).

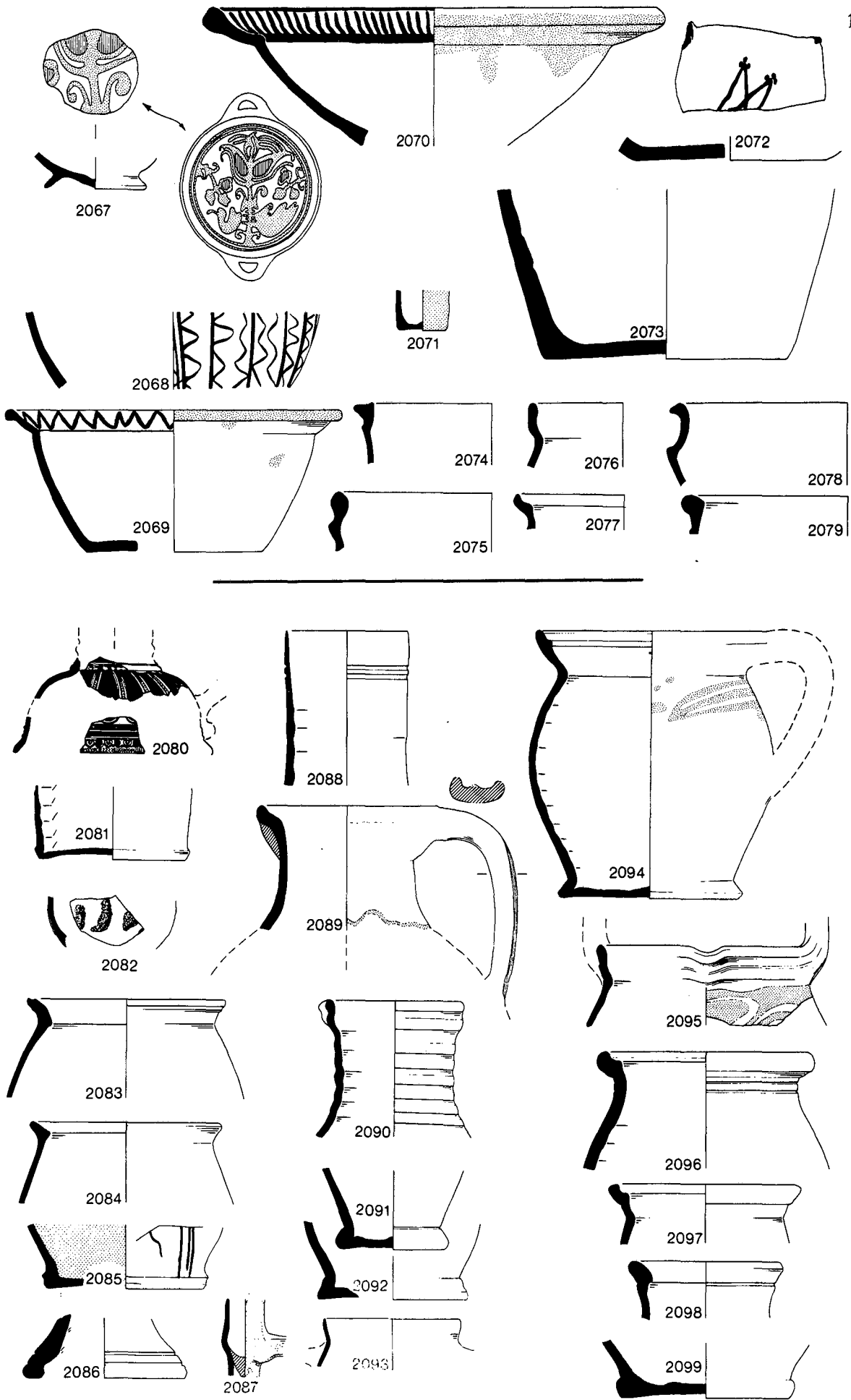

Fig. 90. Valiant Soldier 61 and 63, c. 1620-50 (scale 1:4).

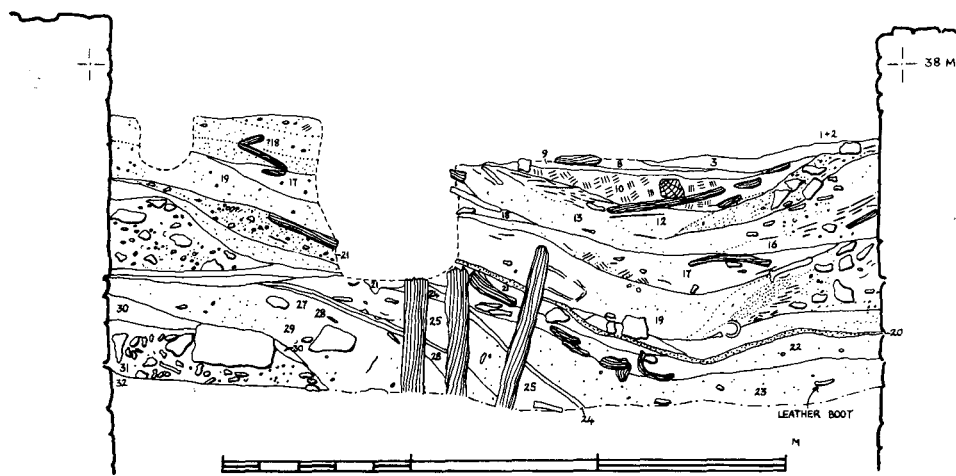

Fig. 91. Long section of Trichay Street 316.

cup rim; 2094 chamber pot; 2095 bucket-handled pot; 2096-8 jar rims; 2099 base.

*Date:* There are numerous joining sherds between VS 63 and VS 61 and they are very similar in character. They also closely resemble GSH 20. All the sgraffito-decorated sherds in these groups are of the crude line-decorated type. A date of c. 1620-50 is indicated.

#### TRICHAY STREET 316 (Figs. 91-6)

These finds come from a large stone-lined industrial pit. Only the top 2 m of its fill were excavated; it was at least 2 m deeper. The excavated layers can be grouped together as follows (Fig. 91):

- (i) Layers 20-30 were largely black anaerobic organic deposits with strands of compacted silt.
- (ii) Layers 13-19 comprised a series of soft, greenish deposits with very large quantities of bone, wood, shell, pottery and leather. These are almost certainly a household rubbish dump.
- (iii) Layers 3-12 consisted of successive deposits of dark anaerobic fibrous material with waterlogged wood.
- (iv) Layers 1 and 2 were deposits of rubble, mortar and slates. These were removed before the section was drawn (Fig. 91).

This group presents serious difficulties of interpretation. The clay pipes suggest that layers 1-17 are in fact of much the same date, c. 1660-70. This dating is confirmed by the character of the delftware, with vessels of shortly after 1660 in both layers 1-7 and 17 (2103, 2118). Moreover there are many joining sherds from vessels scattered through these layers. Layers 18 and 19 also appear to be of much the same date, since several sherds in these deposits join those stratified higher in the pit. However many of the pots in these layers (2125-7, 2128, 2130, 2137-40) are of types which are very probably considerably earlier in date. Moreover the leather in layers 17 and 19 is predominantly early and mid 16th-century material, with some pieces even belonging in the 15th century, and the glass includes several pieces of late 16th- and very early 17th-century type. It is very unlikely that the leather was ancient when discarded. Layers 20-4 pose a similar problem, with two probable late 16th-century Frechen jugs (2123-4) and late 15th- or 16th-century coarsewares (2141-3, 2159), but also containing a mass of leather dating principally to the late 14th and 15th centuries, together with a mixture of late medieval and post-medieval glass (G.44, 46, 94), and a coin forger's dies dating between 1351 and 1413.

It appears that this pit, like GS 228, was used for perhaps two centuries, with rubbish accumulating in the soft organic layers of the pit bottom. It may perhaps have been partially cleaned out at some stage. However it is far from clear why, despite careful excavation, the contents of individual layers differ so widely in date.

#### Summary of dating evidence

##### Clay pipes: (CP.12-26)

- L.1-13: group of 21 bowls, many of c. 1660-80.
- L.17: 2 of c. 1660-80.
- L.19: stems.

##### Glass: (G.41-2, 44, 46, 94-108, 174)

- L.1-3: G.174, c. 1650-60.
- L.7-17: G.95, 97-108. G.95-6, late 16th/early 17th-, G.105, mid 17th-century, others mainly early 17th-century.
- L.19: G.41-2, late medieval.
- L.20-4: G.44, 46, late medieval, G.94, 96 late 16th/early 17th-century.

##### Leather: (L.38-65)

- L.17-19: group of mainly early and mid 16th-century with others of c. 1610-30.
- L.20-4: includes several pieces of c. 1350-1450, late 15th, and early 16th centuries.

##### Numismatica: (CW.3, D.1-2)

- L.23: coin weight CW.3, ?17th-century; coin dies D.1-2 of 1351-1413.

##### Imports and delftware

- 2100-1 Chinese porcelain vessels. 2100 saucer-dish painted in underglaze blue *int* with two deer and a bird under a pine tree, *ext* with bird on branch, Wan Li, c. 1585-1600 (from L.16) (Pl.1); 2101 small Chinese porcelain cup with bank of blue hatching (L.12). Scrap of Montelupo tin-glazed bowl; *int* painted light blue, red-brown and yellow (L.17).
- 2102 Delftware plate with tin-glazed back; front painted mid and dark blue with Chinese figures and landscapes. London type; dated examples belong entirely in the early 1660s (*ex inf.* the late L.L. Lipski) (L.1, 2, 7).
- 2103 Tin-glazed bowl sherd with fine buff fabric, glossy white *ext* and *int*, painted in bright blues. Probably Portuguese, early or mid 17th-century (L.13).
- 2104-14 Dutch-type delftware of c. 1600-50. Laminated pink and buff fabrics with large red earth inclusions up to 4 mm, lead-glazed backs and dull upper surfaces. 2105 porringer painted blue; 2106-14 dishes painted blue, orange and blue (2108) or green and blue (2113); 2105 L.8, 14; 2106 L.16; 2107 L.3, 13; 2108 L.14; 2109 L.16; 2110 L.13; 2111 L.16; 2112 L.3; 2113 L.3; 2114 L.13.
- 2115 Drug jar with plain tin-glazed *int* and mid blue *ext* painting. English or Dutch (L.1, 3).
- 2116 Tin-glazed base with a foot-ring. Possibly Dutch (L.3).
- 2117 Fine tin-glazed cup with corrugated sides. *Ext* painting in light and mid blue with alternating flowers and symbols, separated by characters imitating Chinese porcelain. The characters and leaves are outlined in dark blue. Portuguese, perhaps mid 17th-century (L.1, 13).
- 2118 Handle painted patchy light and dark blue with a yellow dot. *Bleu de Nevers* type, probably London, c. 1660-80 (L.17).
- 2119-20 Plain delftware cup and porringer. Probably London, mid or late 17th-century (L.1, 3, 12; L.1).

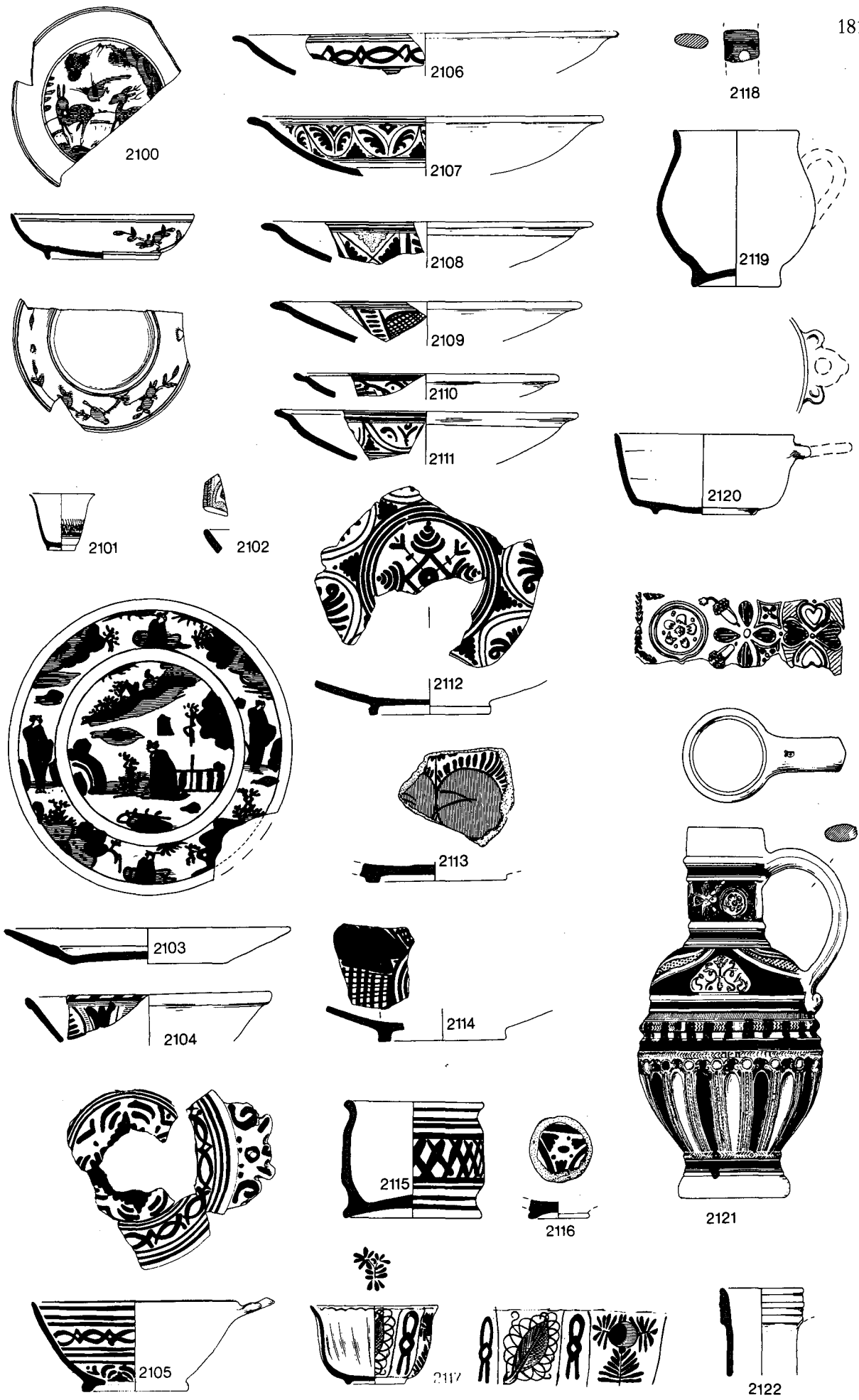

Fig. 92. Trichay Street 316, closing date c. 1660: imports (scale 1:4).



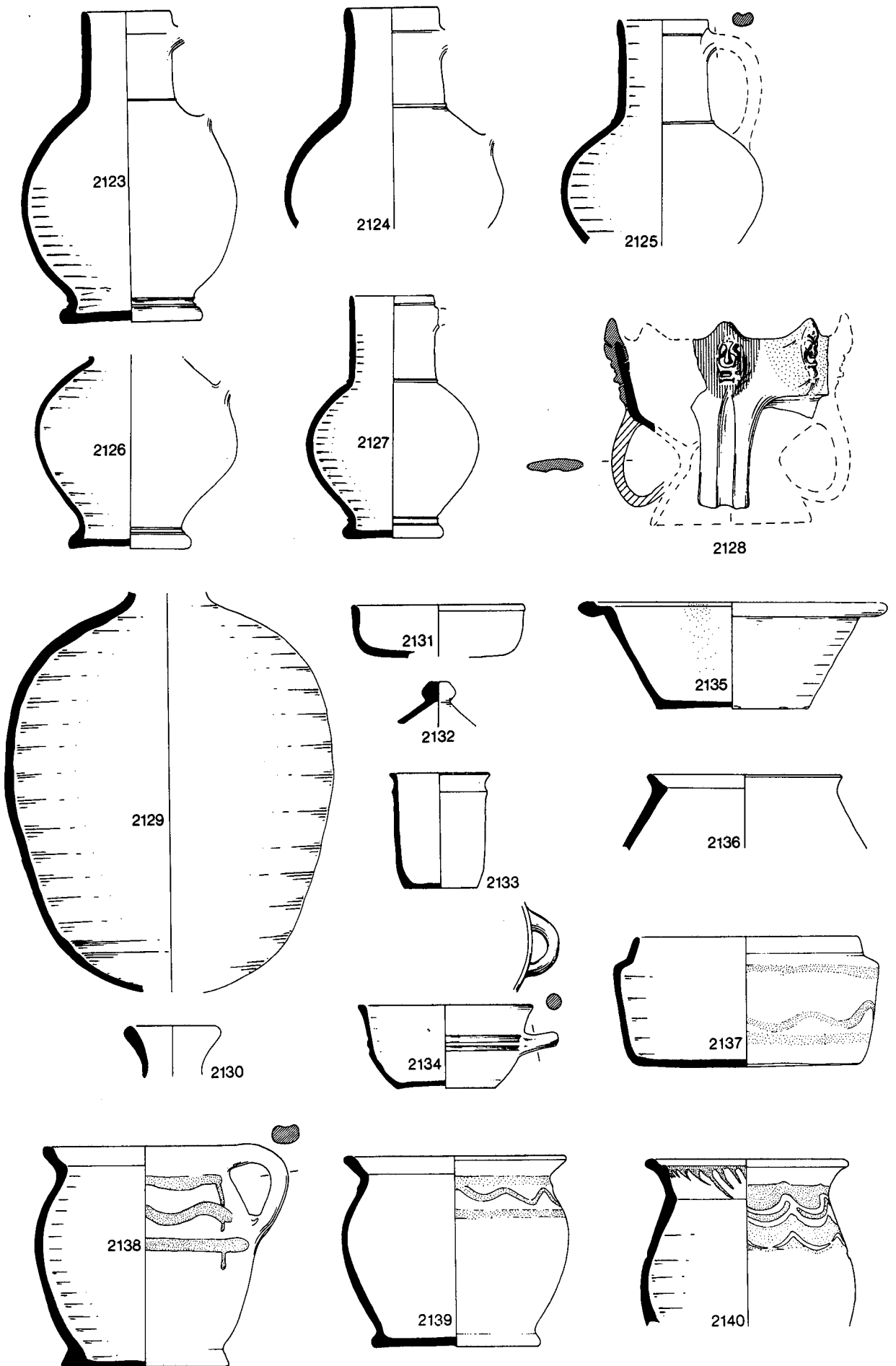

Fig. 93. Trichay Street 316, closing date *c.* 1660 (scale 1:4).

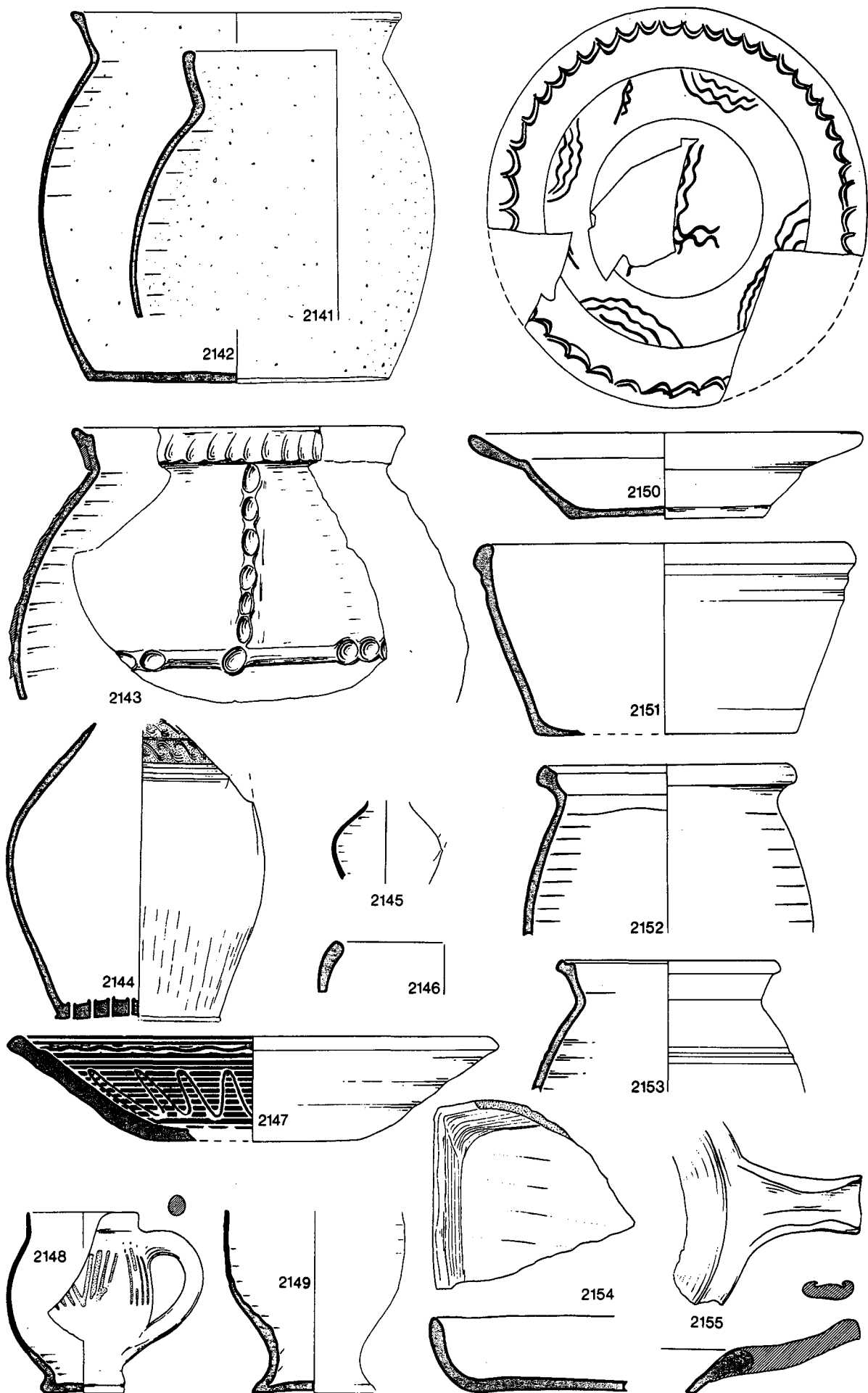

Fig. 94. Trichay Street 316, closing date *c.* 1660: local wares (scale 1:4).

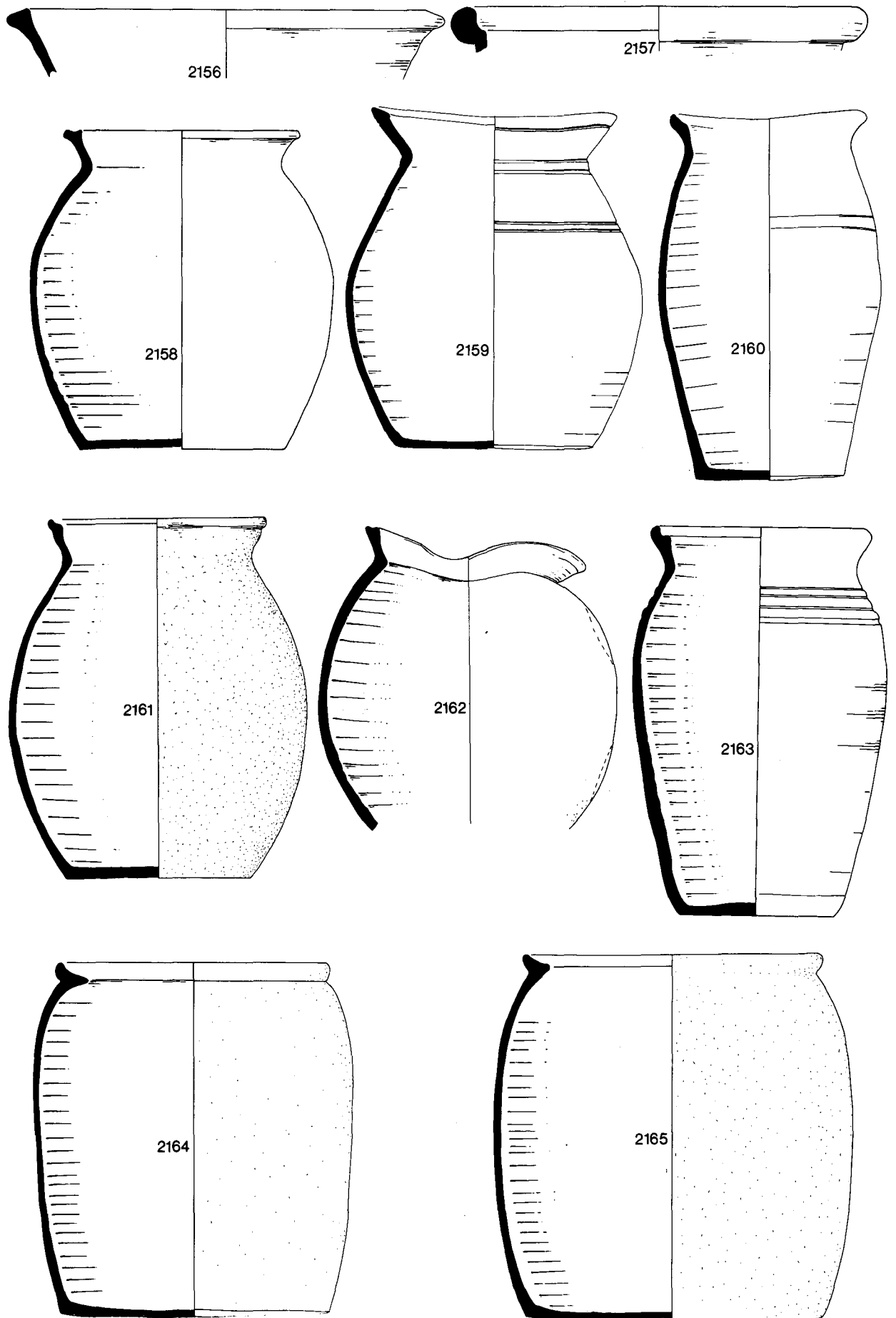

Fig. 95. Trichay Street 316, closing date *c.* 1660: local wares (scale 1:4).

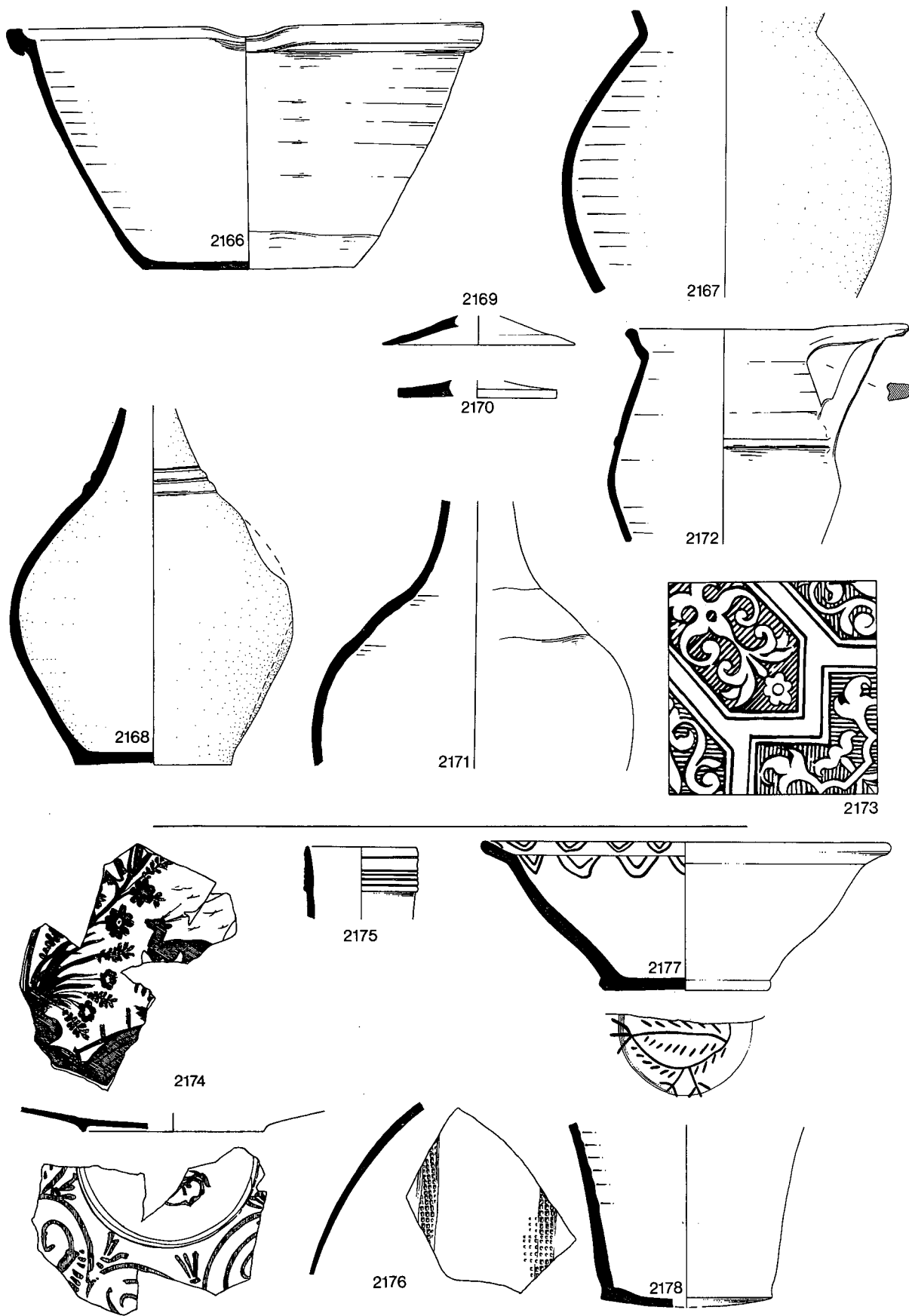

Fig. 96. Trichay Street 316, closing date *c.* 1660; Rack Street 91, *c.* 1640–60 (scale 1:4).

- 2121** Westerwald jug. Moulded decoration on neck (shown at half scale above). Rouletting on shoulder, impressed motif below. Impressed decoration on central band. Blue *ext* painting, blue *int*. Cf. Reineking-von Bock 1971, Nos. 476–83 c. 1600–20 (L.13, 15, 16 and 17).
- 2122–7** Frechen stonewares. **2122** L.17; **2123** L.20, 22; **2124** L.22; **2125** L.17; **2126** L.19; **2127** L.13.
- 2128** Saintonge type 1A chafing dish (Hurst 1974b, 239) (L.17).
- 2129** Spanish olive jar with patchy *int* dull green glaze and *ext* slip (L.2, 13, 14, 16, 17).
- 2130** Neck of an olive jar with typical granular grey fabric but of 'early style' form (cf. Goggin 1960, 7–17). Slip-coated unglazed surfaces (L.13).
- 2131** Small ?dish. Unglazed soft light grey-buff fabric with fine mid grey inclusions. Source unknown (L.3).
- 2132** Small ?lid. Very fine soft light buff fabric with unglazed cream surfaces (L.17).

*Not ill:* Saintonge bowl sherd with *int* slip over white body and brilliant mid green glaze (R.G. Thomson ident.); flat base with a vesicular pink fabric, *ext* slip and spot of green glaze, possibly Spanish.

#### English wares

- 2133–5** Surrey-Hampshire white wares. **2133–4** glazed yellow; **2135** glazed green (L.16; L.13; L.16).

#### Local wares

- 2136** North Devon type 14 jar (L.3).
- 2137** Cucurbit. Granular St Germans- or Totnes-type fabric with *int* mid green glaze and *ext* brushed white slip lines. Although the form is identifiable as a cucurbit (cf. Moorhouse 1972a, 111–14) it is not visibly burnt (L.13, 17, 19).
- 2138–40** North Devon white-painted wares, glazed *int* (L.13; L.17; L.17).
- 2141–6** South Somerset 15th/16th-century wares. **2141–2** type 4 gritty ware cooking pots, not sooted; **2143** type 12 storage jar with applied strips; **2144** watering pot with brushed slip band with combed S pattern and knife-trimmed base; **2145** small cup; **2146** vessel form uncertain, with *int* red glaze (L.25–9; L.25; L.20; L.2, 13, 14, 16, 20; L.3; L.13).
- 2147–55** South Somerset 17th-century types. **2147** type 3A dish; **2148** type 8B cup; **2149** jug base with *ext* dark mauve-black glaze; **2150** type 3B dish; **2151** type 1G bowl; **2152–3** jars with *int* dull green glaze; **2154** rectangular pan with *int* glaze, sooted *ext*; **2155** circular pan, glazed *int*, probably sooted. (**2147–50** L.13, 14; L.1; L.1; L.12, 16, 17; **2151–5** L.3; L.13; L.15; L.13; L.7).
- 2158,**  
**2163** North Devon jars. (L.17, 20; L.23).
- 2156–7,**  
**2159–62,**  
**2164–8** Coarse Sandy wares. **2156–7** type 1 bowls, sooted *ext*; **2159–62** type 4 and 10 jars, the last grossly distorted but capable of being used; **2164–5** type 9 jars; **2166** type 1A bowl, sooted *ext*; **2167** ?type 4 jar; **2168** type 6 ?bottle. (**2156–7** L.13, 17, 19; L.13, 17; **2159–62** L.23; L.3; L.13, 14, 18; L.13, 16; **2164–5** L.18; L.13, 14, 18; **2166–7** L.7, 13, 17, 19; L.13, 15, 17).
- 2169–72** Wares of uncertain origin. **2169–70** lids with fine grey fabric; **2171** jar/bottle with fine buff-grey fabric and pale whitish-grey unglazed surfaces. This may be an import, perhaps from Iberia; **2172** pipkin with *int* mid green glaze and *ext* sooting, perhaps from South Somerset. (L.17; L.19; L.17; L.13, 17).

#### Building materials

- 2173** Dutch lead-glazed tile with field of yellow-glazed slip, outlines of design glazed red-brown. Red fabric, nail holes at corners. Examples with this stamp are known from Gouda (de Jonge 1971, Fig. 2c) and from Southampton (Platt and Coleman-Smith 1975, 2, 201, No. 1469, wrongly reconstructed). The Exeter tiles appear to have been used, since there are traces of mortar on the bevelled edges of some of them. No example is worn, suggesting that they were employed in a wall rather than a floor. Tiles of

this type have recently been discussed by Horton (1981, 242–6) who dates them to the 1550s and suggests that they were made near Middelburg or Antwerp. He notes a further example from Oxford (*ibid.*, 240). (Examples in L.1, 3, 17).

#### RACK STREET 91 (Fig. 96)

*Relations:* Over RS 222 containing clay pipe of type LA, c. 1640–60. Under RS 221, 189 and 124, all with clay pipes of type L1, c. 1690–1720.

- 2174** Tin-glazed plate. Fine light cream fabric with a pale bluish tin glaze, painted with dark blue outlines infilled with paler blue wash. Pale blue painting on the back. Portuguese, possibly mid 17th-century; cf. the vessels from Ballyhack, Ireland (Fanning and Hurst 1975, 106, Fig. 2, Nos. 5, 7).
- 2175** Frechen stoneware.
- 2176** Unglazed Saintonge jug (Hurst 1974b) with applied rouletted strips.
- 2177** South Somerset type 2B bowl with yellow slip and line sgraffito decoration.
- 2178** Cornish vessel. Coarse granular sandy unglazed fabric with large flakes of black and white mica, etc.

*Not ill:* Fine N. Devon combed sgraffito (?c. 1640+).

*Date:* The South Somerset wares, with brushed slipware, green-glazed sgraffito but no spiral-style sgraffito, are typical of the early and mid-century groups. The group also contains many sherds of Coarse Sandy ware; c. 1640–60.

#### GOLDSMITH STREET 96 (Figs. 97–100)

Pit group.

*Clay pipes:* **CP.29–35**. 1 of c. 1620–40; 2 of c. 1640–60; 1 of c. 1650–70; 4 of c. 1660–90; 1 of c. 1660–80.

*Glass:* **G.112–14**

#### Imports

- 2179** Valencian lustreware sherd (Hurst 1977a). Plain tin-glazed back, floral design in lustre on top surface. Mid 15th-century type, probably residual (J.G. Hurst ident.).
- 2180** Spanish tin-glazed cup. Rather coarse pink fabric. Dull *int* tin glaze, *ext* painted in dull grey-blue.
- 2181** Small tin-glazed cup with fine cream fabric, *int* tin glaze with rose tinge, *ext* painting in light and mid blue. Probably Portuguese.
- 2182** Olive jar with *ext* slip.
- 2183–6** Delftware. **2183** dish sherd with lead-glazed back, front painted in orange, blue and bright green, Dutch, c. 1600–50; **2184** closed form, (? a bottle), dated [16] 60; **2185** dish sherd with lead-glazed back, front with bright blue painting, Dutch, c. 1600–50; **2186** plain drug jar.
- 2187** Plain Frechen stoneware.
- 2188** Base of a tripod vessel with fine white fabric and *int* iron-flecked brown glaze. Possibly Surrey-Hampshire.
- 2189** Bowl of Low Countries white ware. Sandy white fabric, *int* yellow glaze. Low Countries form with ring base, horizontal handle.

#### North Devon wares

- 2190** Bowl sherd with *int* crude sgraffito and glaze.
- 2191** Plain type 8 tankard base.
- 2192** Drug jar in pipeclay, glazed yellow. Fired upright.
- 2193** Plain rim, glazed *int*.
- 2194–5** Type 2A jug sherds.
- 2196** Type 10 jar.

#### South Somerset (17th-century types)

- 2197–2222** Sgraffito-decorated wares. **2197–2205** type 3A and 3G dishes; **2206–7** type 4A chafing dishes with knife-cut scoops on rim, **2207** rouletted on rim; **2208–10** type 6 chamber pots; **2211–12** dishes with finger-dragged sgraffito through wet slip; **2213** ?type 12 bucket-handled pot; **2214** ?jar with unglazed band of *ext* slip; **2215** ?rim of bucket-handled pot; **2216** type 8E cup; **2217** bowl with *int* glaze; **2218** ?chamber pot with *int* glaze; **2219–20** type 3E dishes; **2221–2** type 3B dishes.
- 2223–38** Plain yellow-glazed slipwares. **2223** type 3E dish; **2224** chafing dish; **2225** type 3D dish; **2226–9** type 10 candlesticks with partitions inserted after throw-

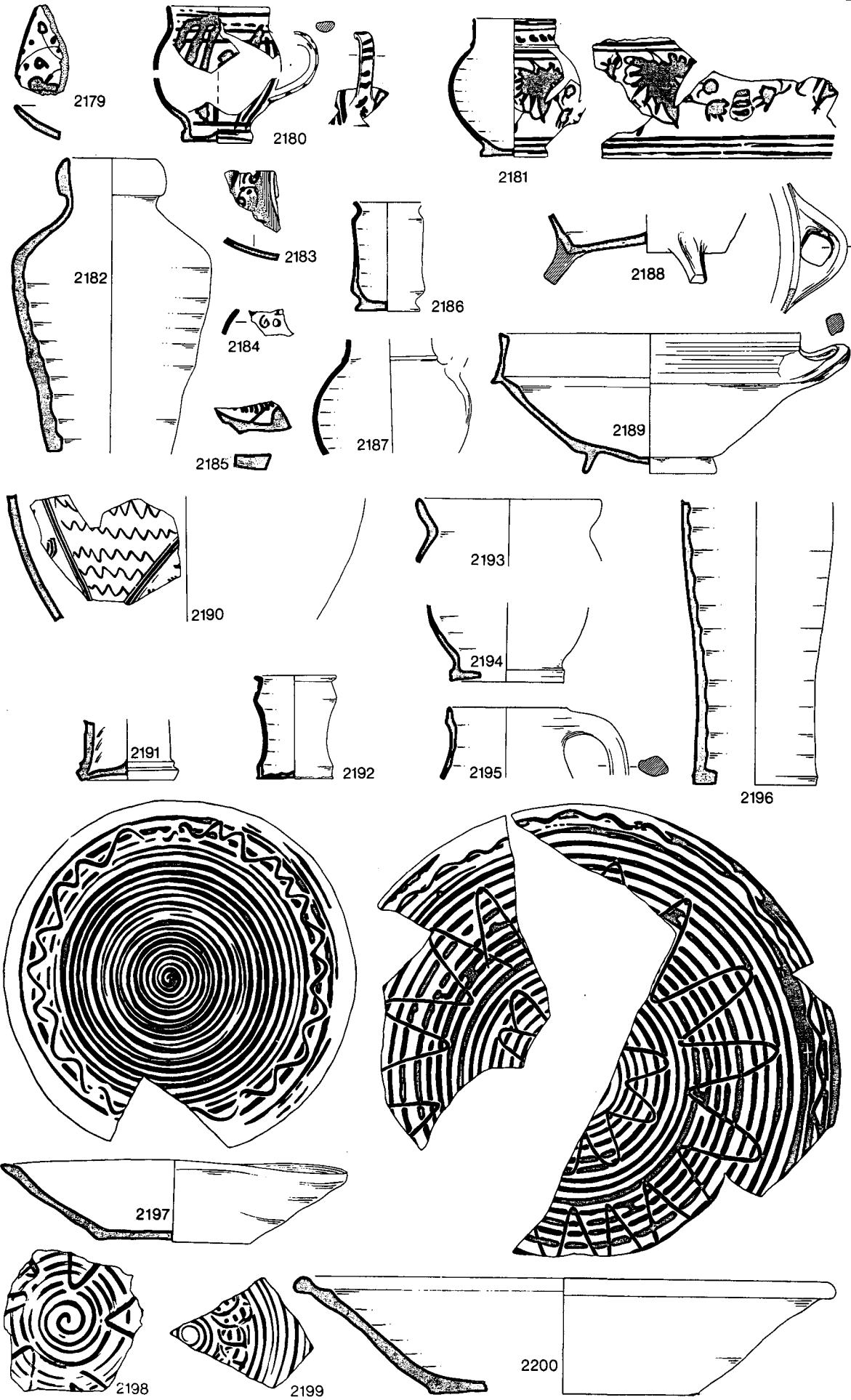

Fig. 97. Goldsmith Street 96, c. 1660-80 (scale 1:4).

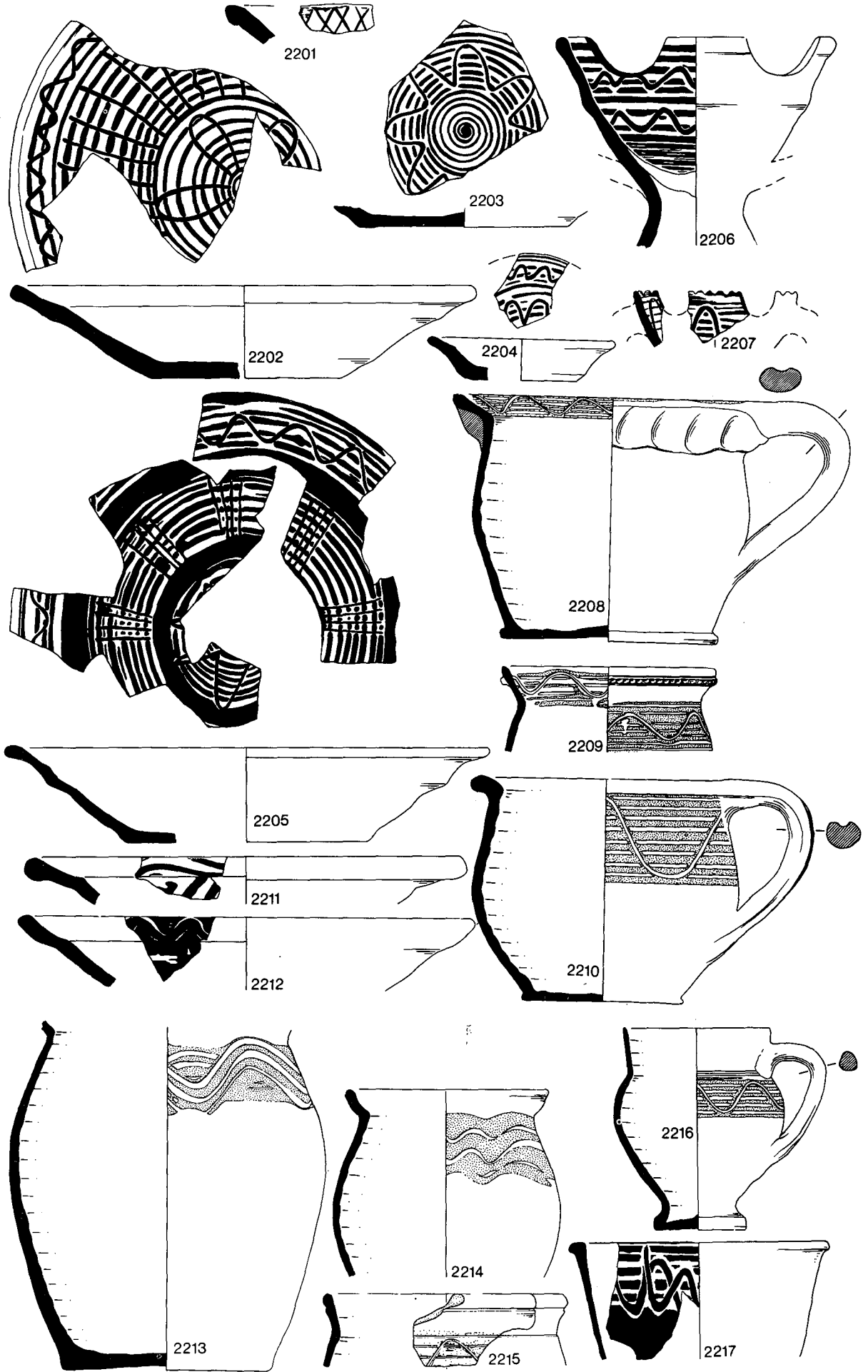

Fig. 98. Goldsmith Street 96, c. 1660–80 (scale 1:4).

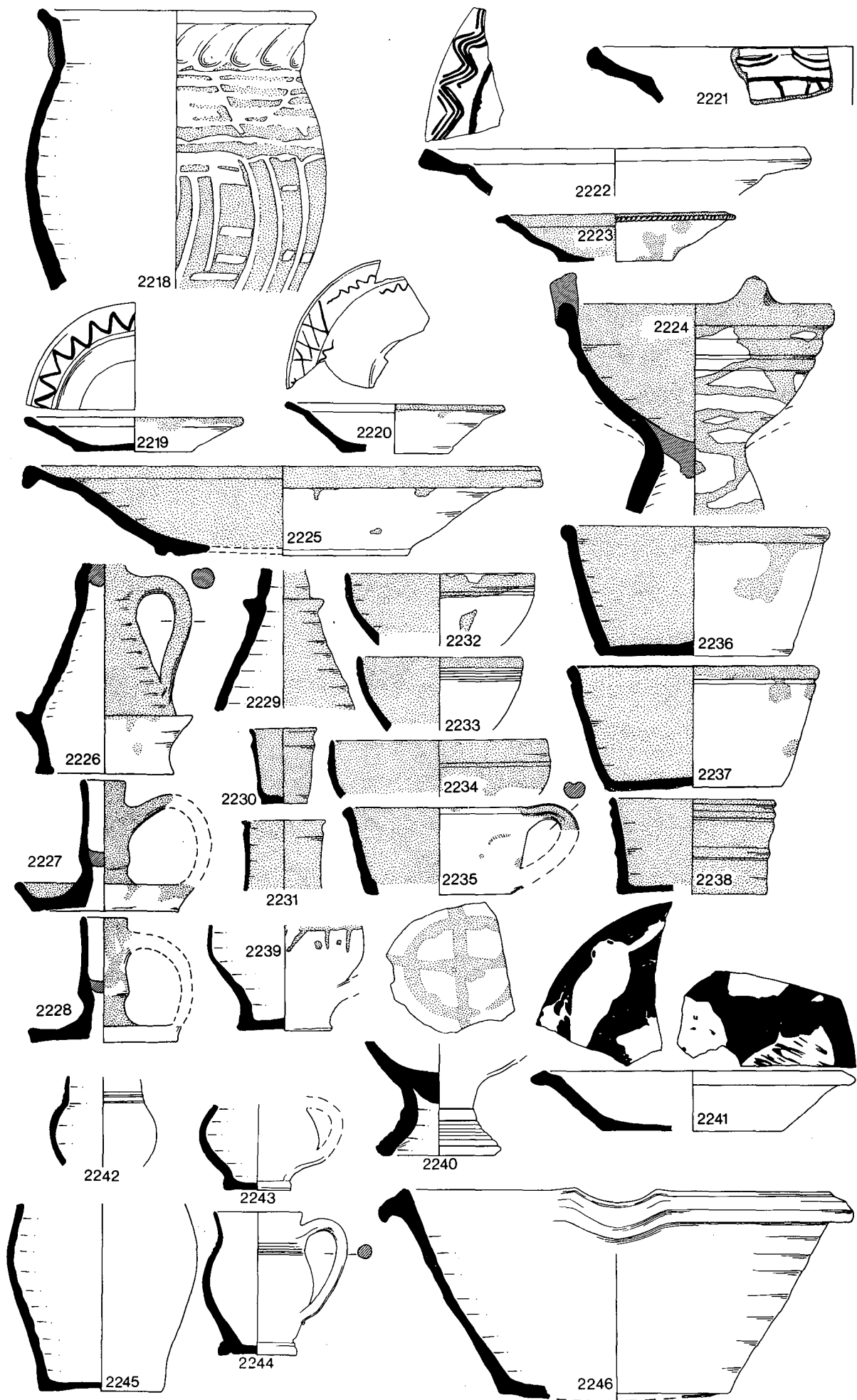

Fig. 99. Goldsmith Street 96, c. 1660-80 (scale 1:4).



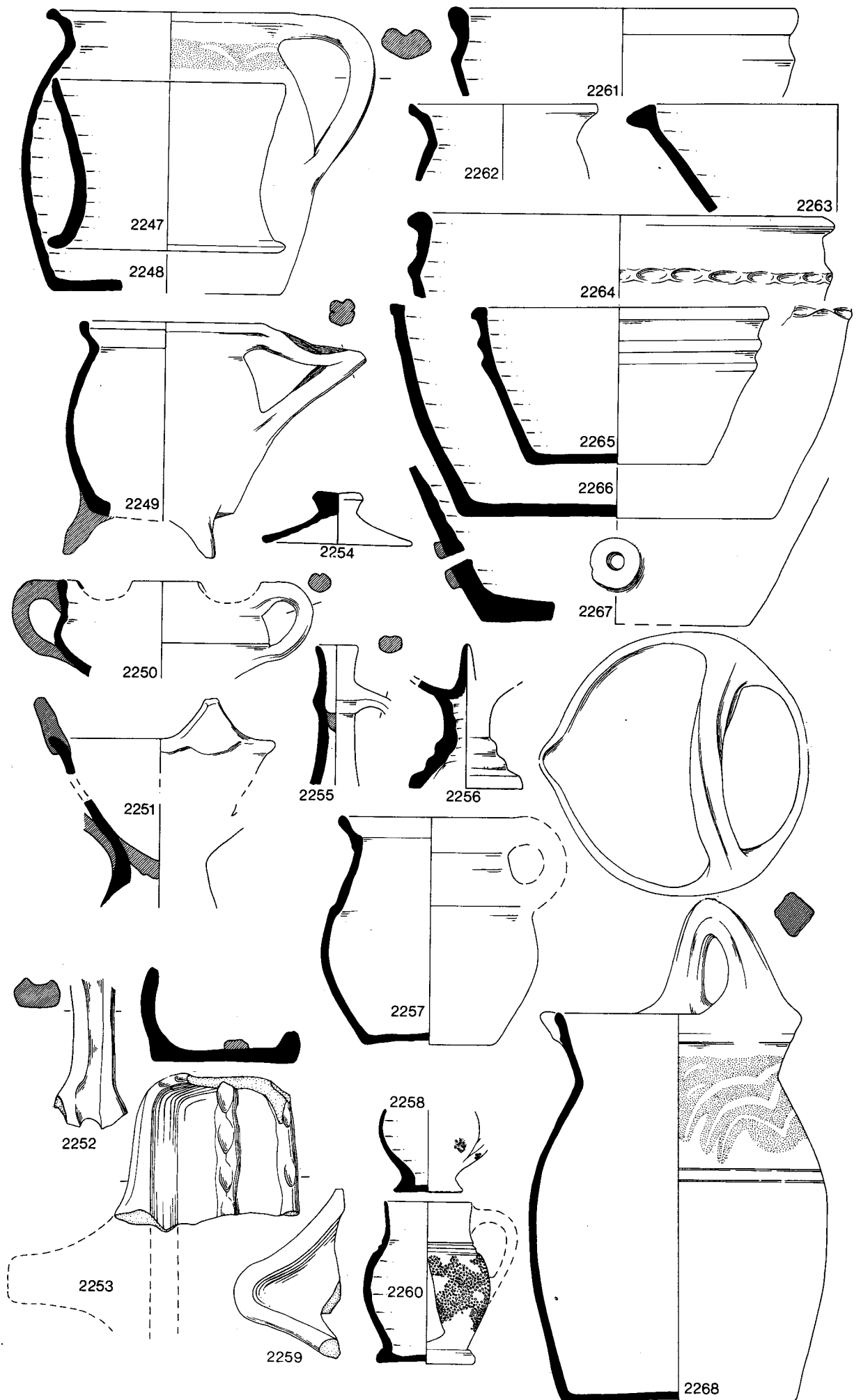

Fig. 100. Goldsmith Street 96, c. 1660-80 (scale 1:4).

ing, some burnt in use; **2230-1** type 14 ointment jars; **2232-5** ?porringers; **2236-8** type 2E bowls.

- 2239-41** Trailed slipwares. **2239** base of a type 8B cup; **2240** chafing dish; **2241** type 3F dish.
- 2242-68** Wares without slip decoration. **2242-4** plain type 8D cups; **2245** jug base; **2246** type 1A bowl; **2247** unusual plain unglazed brick-red vessel, open at both ends, ?industrial function; **2248** chamber pot; **2249** type 7 tripod pipkin; **2250-1** plain chafing dishes with *int* glaze; **2252** unglazed handle; **2253** baking dish, glazed *int*; **2254** type 11 lid; **2255-6** candlesticks, glazed *ext*; **2257** ?chamber pot; **2258**, **2260** cups with *int* glaze, *ext* encrusted quartzite lumps and glaze; **2259** lip of a baking dish, sooted; **2261** type 1D bowl; **2262** jar, glazed *int*; **2267** type 9 cistern; **2268** type 12 bucket-handled pot.

Date: c. 1660-80.

#### NORTH STREET 1501 (Figs. 101-5)

Pit group exposed in 1974 by a mechanical excavator at the rear of 38 North Street, a large late medieval house with elaborate 17th-century additions (Portman 1966, 87-8; a more detailed account of this building will be published in a future volume of E.A.R.).

Clay pipes: including **CP.42-3**. 3 of c. 1620-40; 2 of c. 1660-80; 5 of c. 1660-90; 3 of c. 1680-1700.

Glass: **G.127-46** including *façon de Venise* glasses **G.128-33** of c. 1670.

#### Chinese porcelain (Attributions by J. Ayers)

- 2269** Plate painted in light and dark underglaze blue, the central scene showing a landscape with fishermen and boats. Wan Li, c. 1590-1620. (Pl. 1).
- 2272** Small dish painted in underglaze blue with a 'bird on the rocks' scene. Wan Li, c. 1590-1620 (Pl. 1).
- 2273-7** Sherds from small dishes (**2273**, **2275-6**) and two cups (**2274**, **2277**). All appear to be Wan Li sherds, but the small size of **2273** and **2276** makes their attribution rather uncertain (Pl. 1).

#### Tin-glaze

All sherds have a fine cream-buff fabric.

- 2270** Sherd from a Ligurian faïence dish. Leaves painted in pale green, mid blue and red-brown, stag in ochre-yellow; all outlined in black. Tin-glazed back with pale blue lines.
- 2271**, **2278-81** Dutch delftwares. **2271** c. 1670-80; **2278** moulded handle, late 17th-century; **2279** and **2281** c. 1670-80.
- 2282** Dish painted mid and dark blue. Typical spirals of Portuguese wares. ?From Lisbon.
- 2283-4** Dutch delftwares. **2283** c. 1680, cf. de Jonge 1970, Figs. 4-5; **2284** with greyish-blue painting, c. 1680.
- 2285** Dutch or English deep dish with lead-glazed back, c. 1620-40.
- 2286** As **2279**.
- 2287** Dish base painted in dull blues with lead-glazed back, cf. Rackham 1926, Pl. 44b; Korf 1973, Fig. 14. Dutch, early 17th-century.
- 2288-91** Drug jars painted blue-and-orange (**2288**) or blue (**2289-91**).
- 2292** Deep dish. Front painted with 'chinamen among grasses'. London type: all the dated examples belong in the early 1680s (*ex inf.* the late L. L. Lipski). cf. Garner and Archer 1972, Pl. 43B, dated 1684.
- 2293-2311** Plain delftwares. **2293-6** drug jars; **2297-8** cup sherds; **2299** bowl base; **2300** chamber pot; **2301** porringer (with room for a second handle); **2302** ?cup base; **2303** plates. Many of these are paralleled in London: **2298** and **2301** cf. Bloice 1971, 124, Nos. 62A, 62B; **2297-8** cf. Garner and Archer 1972, Fig. 6; **2205-11** Garner forms A and B.

#### Stonewares

- 2312** Large Frechen Bellarmine with flowing beard; medallion with crowned arms of Jülich, Cleve, Berg and Mark with lion supporters. Sherds of a further jug with the same medallion stamp are also present in the group.
- 2313-16** Frechen Bellarmines. **2313** one of four near-complete examples with this mask and medallion.
- 2317** Plain Frechen jug.
- 2318-23** Westerwald wares. **2318-19** tankards with applied

decoration, painted blue and mauve, the top band of **2318** with scrolls, raised dots in background, the hearts in the lower bands glazed alternately blue and mauve; **2320-3** jugs. For **2320** and **2322** see Reineking-von Bock 1971, Nos. 511-19.

#### English wares

- 2324-30** North Devon wares. **2324-6** type 1C dishes; **2327** type 5 porringer; **2328** rim of a drug jar in white pipeclay fabric, glazed usual yellow; **2329** type 10 jar; **2330** type 1B dish showing a man amongst boscaige with birds. Mr. S. Hunt has suggested (pers. comm.) that this may depict Charles II hiding in the Boscobel oak. The style of the sgraffito decoration is closely comparable to that of vessels excavated by Mr. T. J. Miles from the North Walk kilns at Barnstaple which include sherds dated between the late 1660s and the 1680s.
- 2331** Surrey-Hampshire drug jar with *int* yellow glaze.
- 2332-56** South Somerset 17th-century types. **2332** type 14 slip-coated drug jar, glazed yellow *int*; **2333** type 2C bowl; **2334** type 6B chamber pot; **2335** chafing dish base. On bowl, *int* slip glazed yellow and line sgraffito. **2336** dish with 'finger-dragged' slip, glazed red-orange over body, yellow over slip; **2337** jug base with slip, glazed yellow; **2338** black-glazed cup; **2339** type 3D cup; **2340** type 11 lid; **2341** cup base, heavily over-fired to near-stoneware. This closely resembles Donyatt ware over-fired experimentally by Mr. R. Coleman-Smith; **2342** type 14 drug jar with *int* brown glaze; **2343** horizontal handle; **2344** jug base with *int* glaze; **2345** type 1C bowl; **2346-7** type 1E jar rims; **2348** bowl, Coarse Sandy ware, type 1C, sooted; **2349** rim with *int* glaze; **2350** type 12 bucket-handled pot; **2351-2** type 1H bowls; **2353** jar with *ext* slip, *int* dark green glaze; **2354-6** type 1E bowls.

#### Tiles

- 2357-8** Sherds with cream fabric 17 and 13 mm thick with tin glaze and orange and dark blue painting; green on **2358**. **2358** comes from a common design showing a high-handled vase holding marigolds (de Jonge 1971, Fig. 19a; Lane 1939, Pl. 32). Dutch, early 17th-century.

Date: c. 1680-90.

#### GOLDSMITH STREET 98-9 (Fig. 106)

Two adjoining and possibly contemporary pits with many joining sherds, treated as a single group.

Clay pipes: **CP.50-2**, c. 1670-90; others of types LB, LC, c. 1660-90.

Glass: **G.89**, early or mid 17th-century.

- 2359** Dutch or English delftware dish with lead-glazed back. Early or mid 17th-century.
- 2360** Dutch or English delftware drug jar.
- 2361-3** Frechen stonewares. The medallion of **2361** is not known at Fulham (*ex inf.* Miss A. Clark), so is probably a Frechen product; **2363** with impressed stamp.
- 2364-5**, **2367** Saintonge marbled wares. **2364** bowl with handle-scar, *int* marbled slip glazed pale yellow and brownish-green, *int* of base burnt, apparently from use; **2365** jug sherd with *ext* marbled slip extending over handle and signs of burning; **2367** dish sherd.
- 2366** Bristol-Staffordshire yellow slipware cup with trailed black slip on handle, pale brown and black slips on body.
- 2368** North Holland slipware.
- 2369-70** Small drug jars of Surrey-Hampshire white ware with *int* yellow glaze.
- 2371-7** North Devon wares. **2371** type 1C dish; **2372** type 8 tankard; **2373** green-glazed cup; **2374-7** dishes.
- 2378-85** South Somerset 17th-century types. **2378-9** type 3A and 3B dishes; **2380** type 8D cup; **2381** type 5B jug; **2382-5** type 1G and 1F bowls.

Not ill: South Somerset types 3A(3), 5(3), 7, 8A(2), 12.

Date: Typical group of c. 1670-1700.

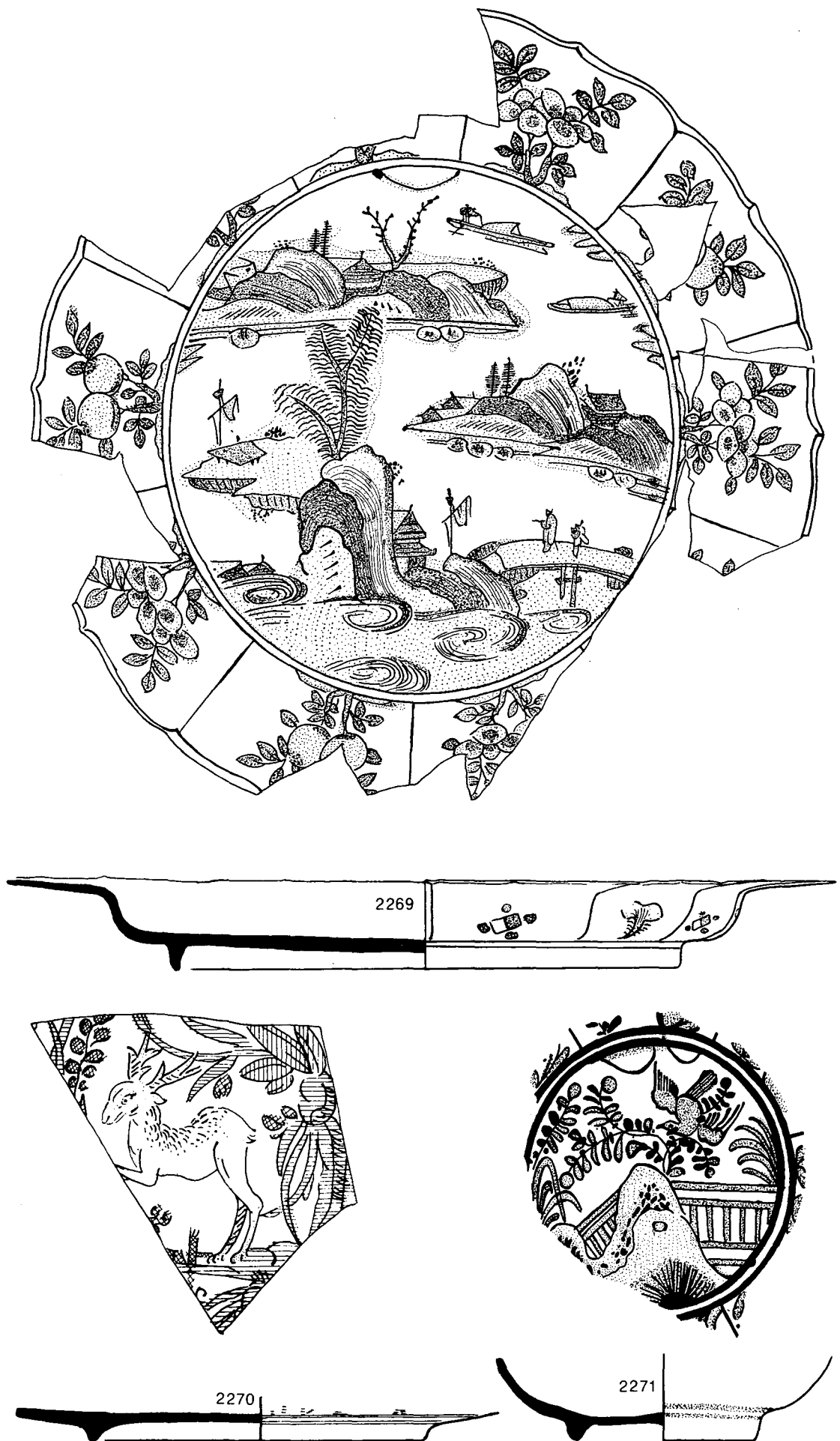

Fig. 101. North Street 1501, c. 1680-90: porcelain and tin-glazed wares (scale 2:3).



Fig. 102. North Street 1501, c. 1680-90: porcelain and tin-glazed wares (scale 1:2).

GOLDSMITH STREET 80 (Figs. 107-8)

Pit group.

Clay pipes: Including CP.44-9, 78, 115. 1 of c. 1660-90; 1 of c. 1670-90; 4 of c. 1670-1700; 2 of c. 1690-1720.

Glass: G.147-8, early or mid 17th-century.

Imports and delftwares

- 2386 (Not drawn) Scrap of blue-and-white porcelain, possibly Wan Li. See Pl. 1.
- 2387 Delftware cup with speckled mauve *ext* glaze and plain white *int*. Mid 17th-century type, probably London.
- 2388 Plain white delftware porringer with two handles, both present. Late 17th-century type, probably London; cf. Bloice 1971, Fig. 54, Nos. 55-60.
- 2389 Deep delftware dish. Plain tin-glazed back, front with painting in strong blue. Pattern not identified.
- 2390 Spanish olive jar with *ext* slip, unglazed.
- 2391-3 Applied stamps from Westerwald stonewares, *ill* at

half actual size, with backgrounds in blue. From jugs like 2320, 2322, late 17th-century.

2394-5

Frechen medallion fragment and Bellarmine.

2396

Pierced sherd from the bowl of a chafing dish with *ext* handle scar. Fine white fabric, rich mid green *int* and *ext* glaze. Possibly north French or Surrey-Hampshire.

2397

Bowl. Soft off-white fabric, *int* pale yellow glaze with painted copper-green pattern. Origin unknown, but see also 2478.

Local wares

- 2398-2409 North Devon wares. 2398 plain slipware, type 1B; 2399-2401 sgraffito-decorated wares, including porringer 2400; 2402-9 gravel-tempered types 3G, 11, 6, skillet, 3C, 2A, 2A, 10.
- 2410-20 South Somerset 17th-century types. 2410-11 type 8A mugs, glazed black; 2412 porringer; 2413 ?bucket-handled pot; 2414-17 types 3E, 7, 1F, 1C; 2418

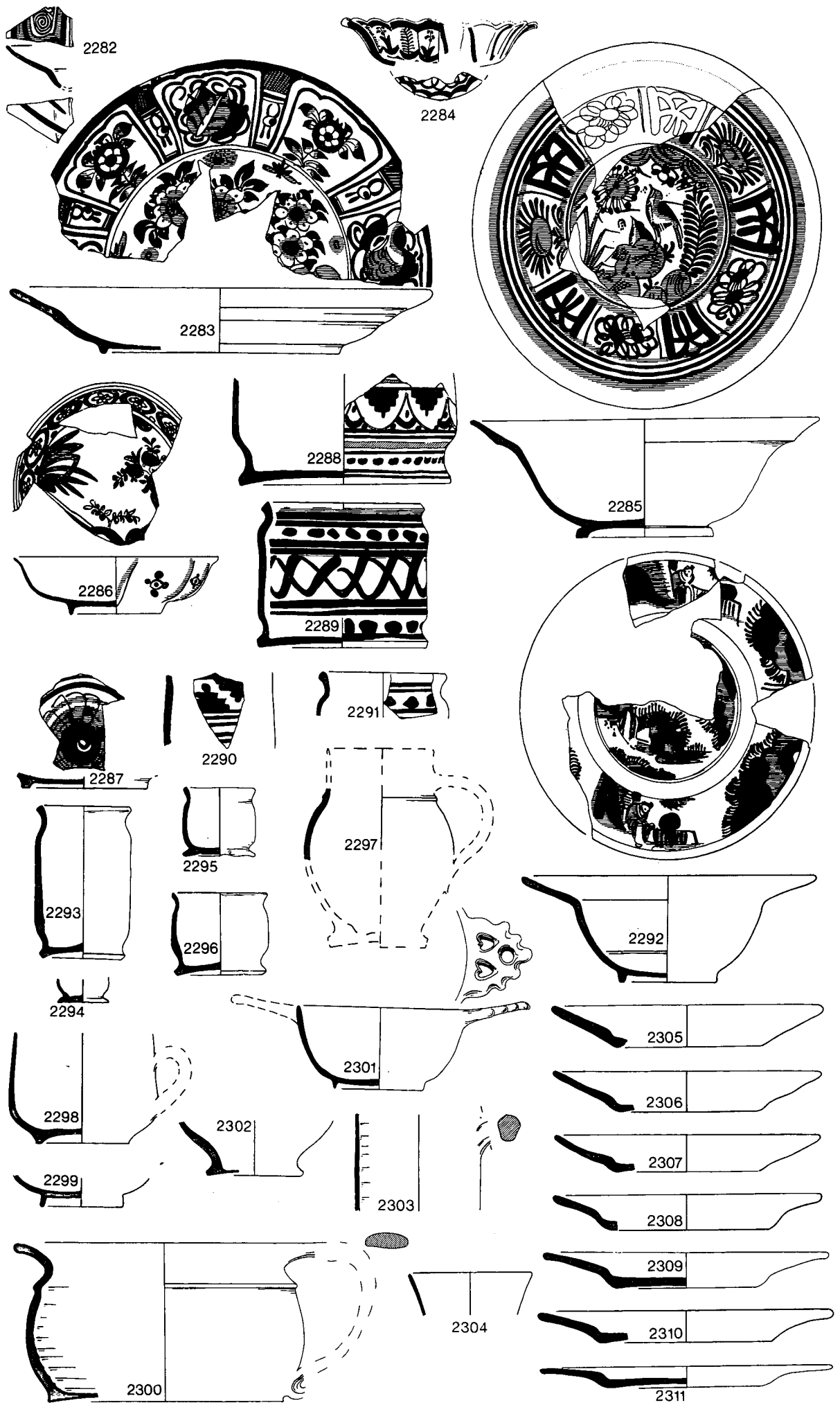

Fig. 103. North Street 1501, c. 1680-90: tin-glazed wares (scale 1:4).

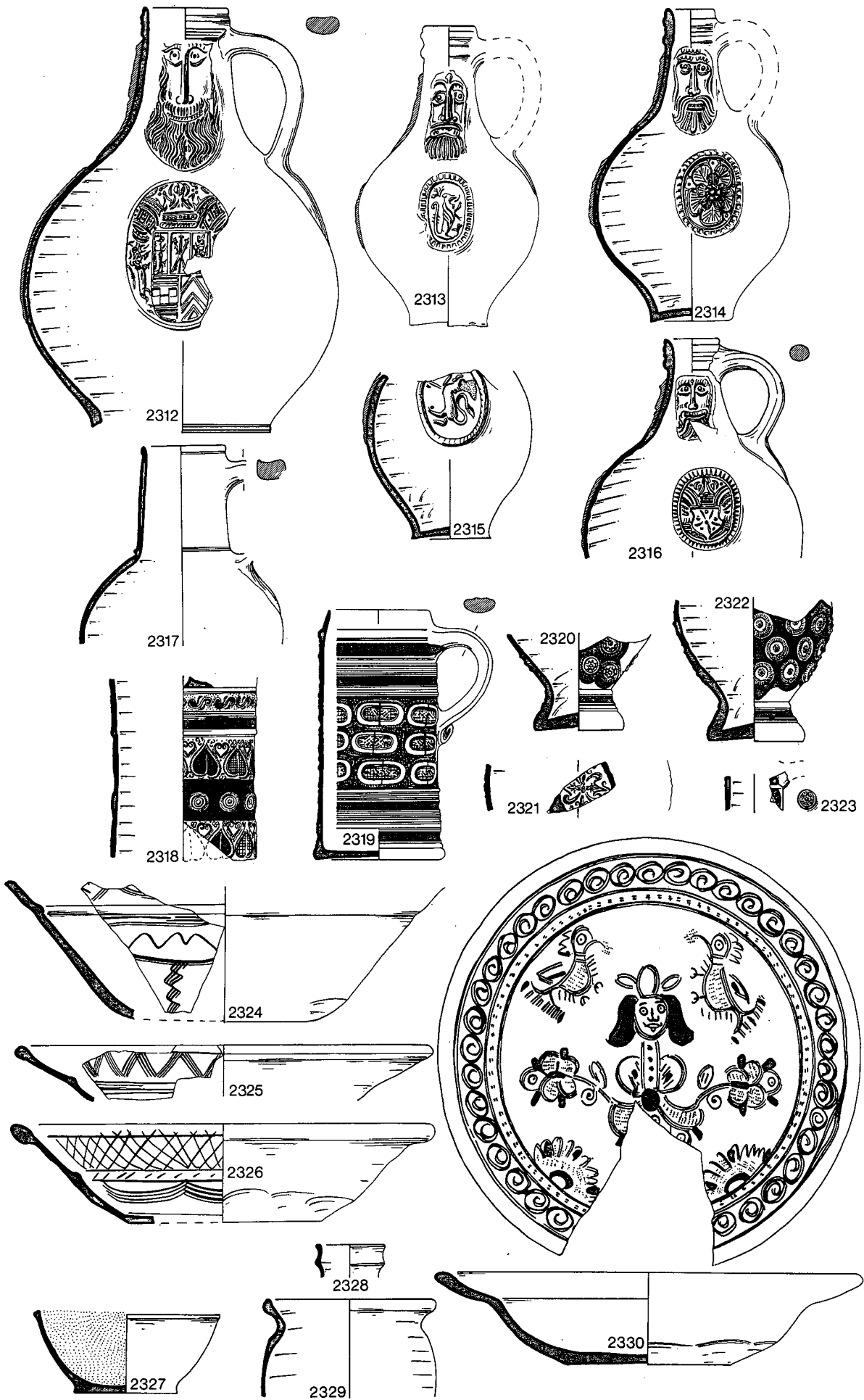

Fig. 104. North Street 1501, c. 1680–90: stonewares and North Devon wares (scale 1:4).

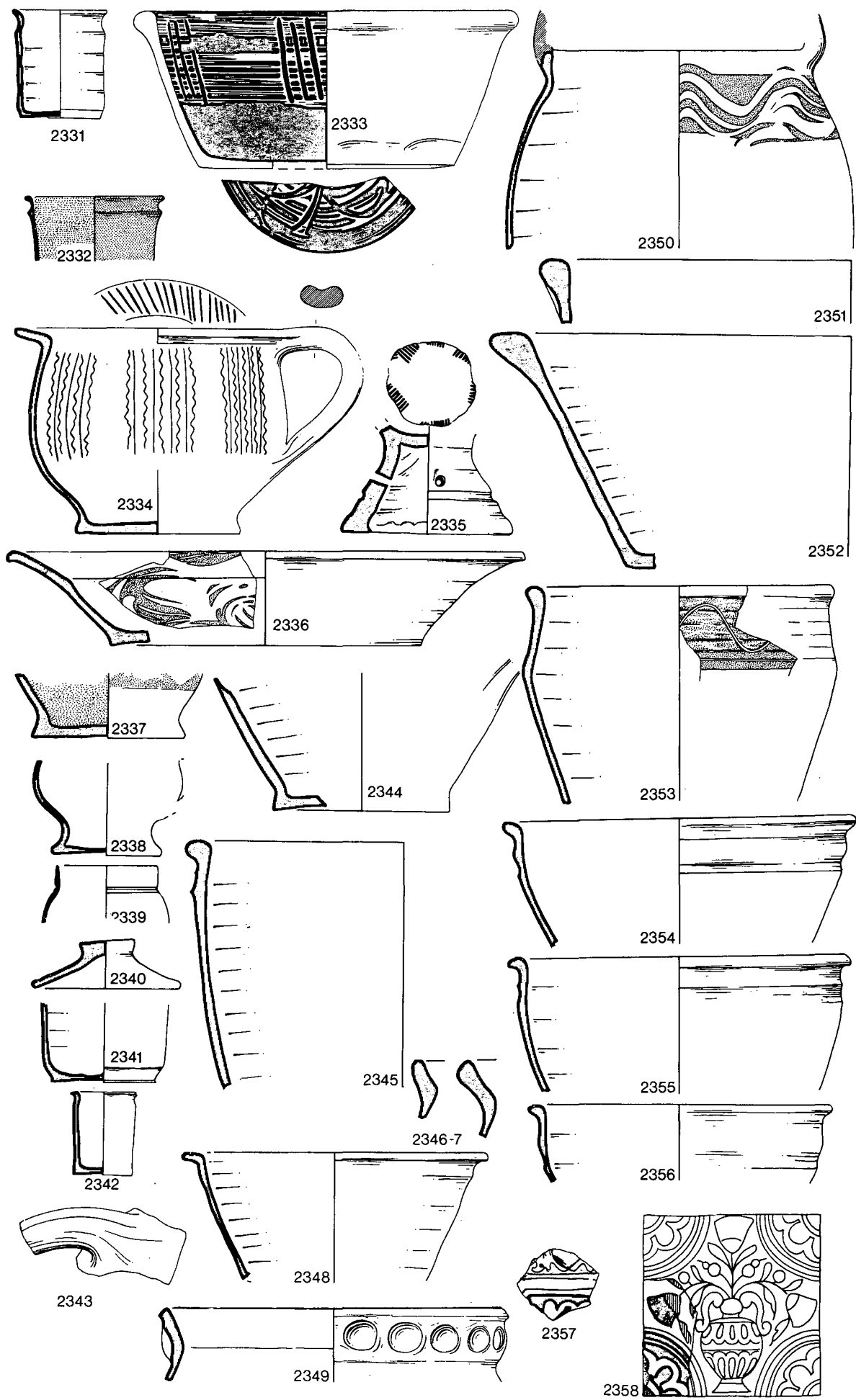

Fig. 105. North Street 1501, c. 1680-90: coarsewares and tin-glazed tiles (scale 1:4).

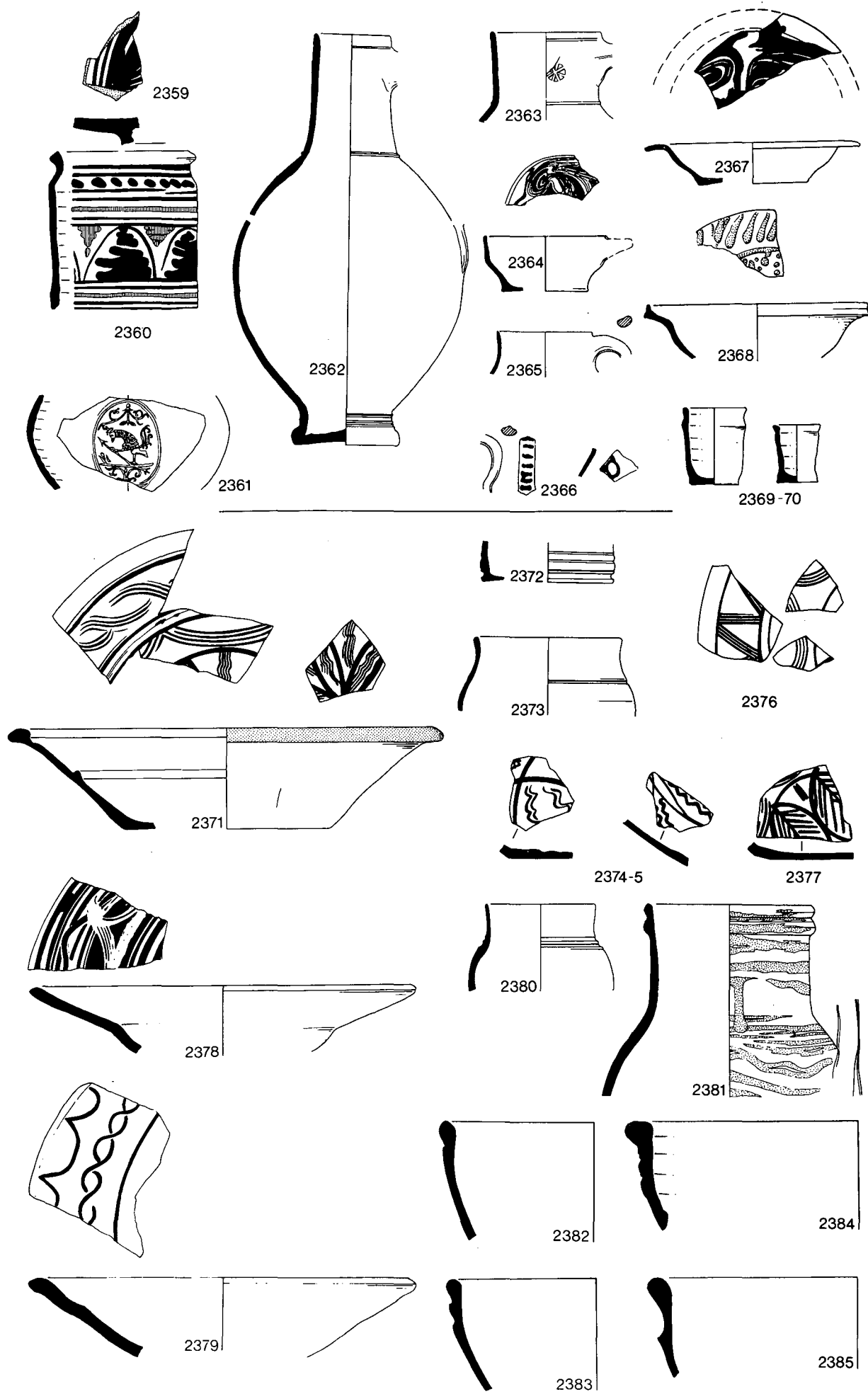

Fig. 106. Goldsmith Street 98-9, c. 1670-1700 (scale 1:4).



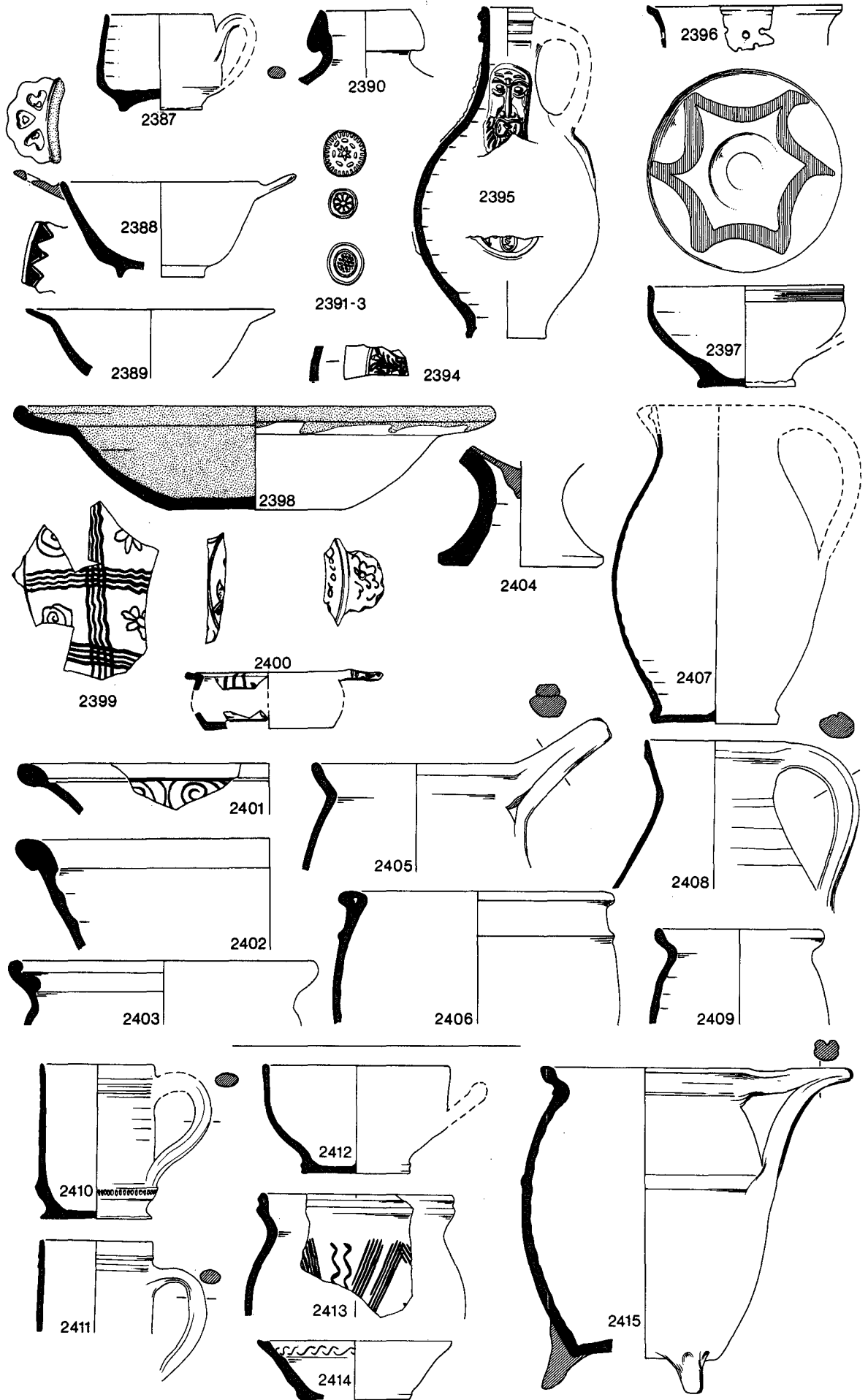

Fig. 107. Goldsmith Street 80, c. 1670-1700 (scale 1:4).

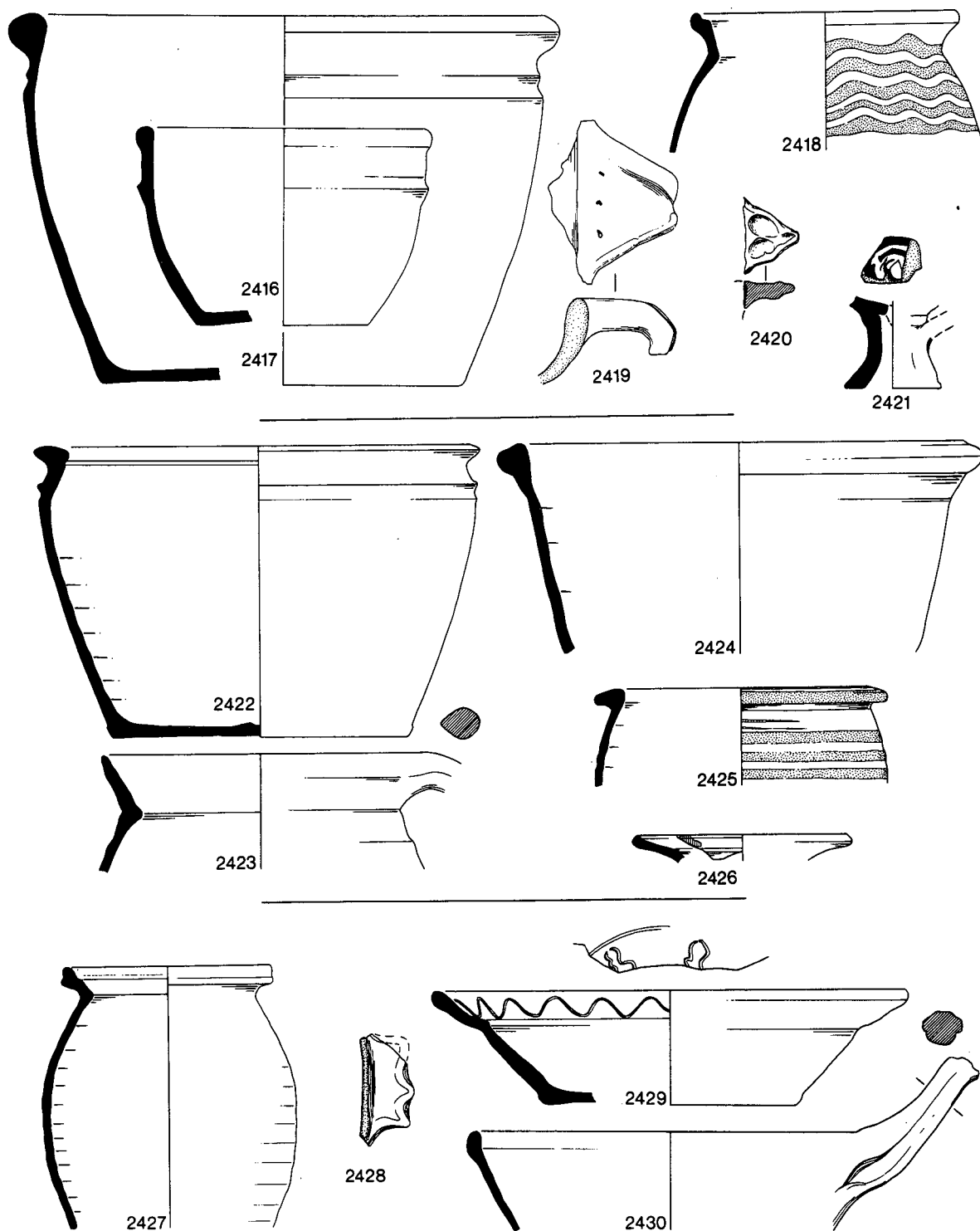

Fig. 108. Goldsmith Street 80, c. 1670–1700; Rack Street 1000, c. 1690–1720; Bartholomew Street West 129, c. 1680–1700+ (scale 1:4).

**2421** jar; **2419** rectangular pan; **2420** type 13A.  
 South Somerset chafing dish with orange glaze of 18th-century wares.  
*Not ill:* S. Somerset types 3A(2), 4, 5(2), 6A, 8A, 12(2).  
*Date:* c. 1670–1700.

**RACK STREET 1000 (Fig. 108)**

Pit group excavated during observation of builders' trenches.  
*Clay pipes:* Type LB, c. 1680–1700; type L1, c. 1690–1720.  
**2422–3** North Devon gravel-tempered wares, both sooted.  
**2424–6** South Somerset type 1H bowl; jar; and dish with *int* pale yellow glaze and patch of copper mottling.  
*Date:* c. 1690–1720.

**BARTHOLOMEW STREET 129 (Fig. 108)**

Pit group.  
*Clay pipe:* Type LB, c. 1680–1700.  
**2427** North Devon gravel-tempered jar.  
**2428–9** South Somerset handle and type 3B bowl.  
**2430** North Devon gravel-tempered type ?4.  
*Date:* c. 1680–1700+.

**GOLDSMITH STREET 107 (Fig. 109)**

Pit group.  
*Clay pipes:* Type LB, c. 1660–90; type LC, c. 1660–90; 5 as CP.45, c. 1670–90.  
**2431** Dish sherds with bright white tin glaze, upper

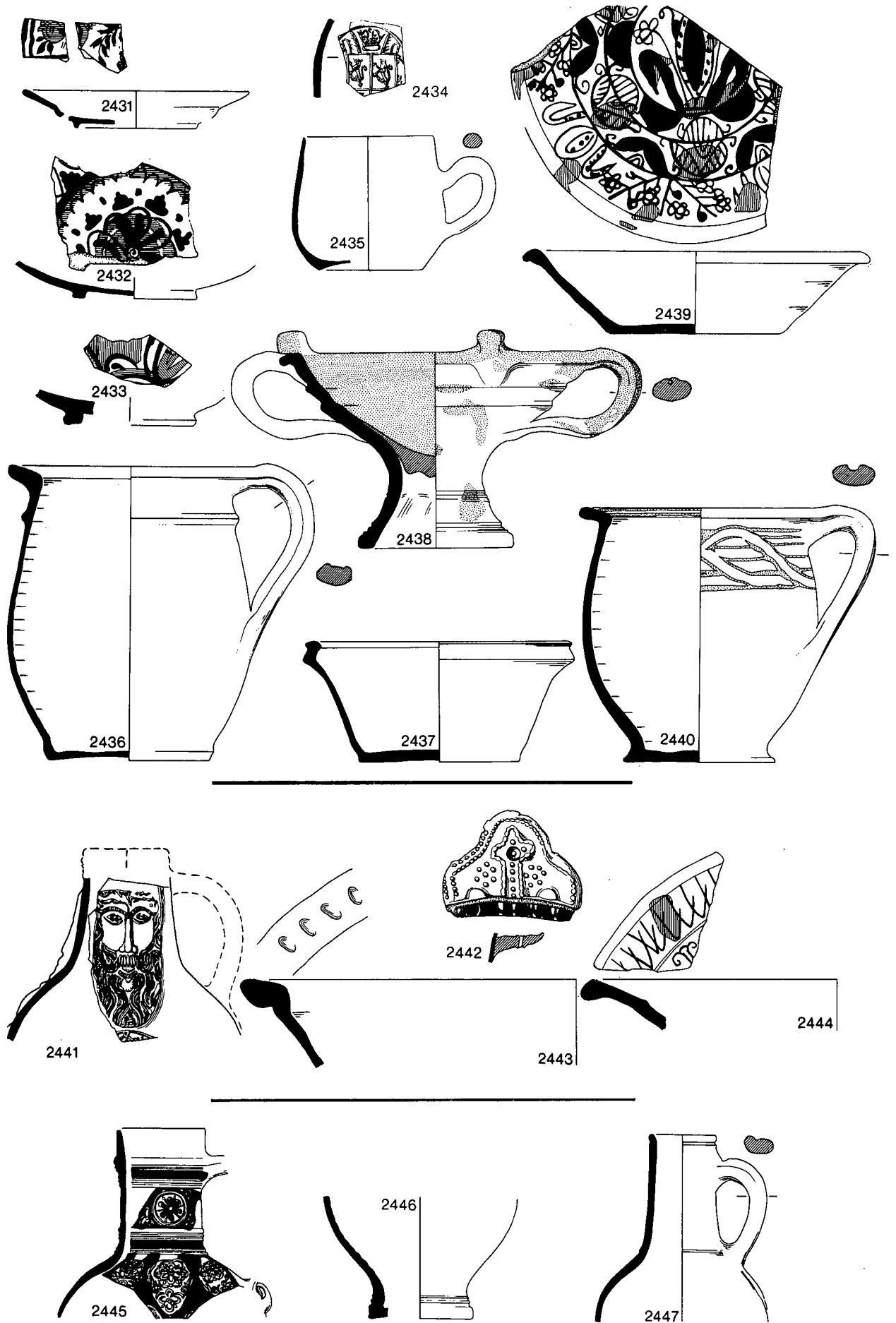

Fig. 109. Goldsmith Street 107, c. 1670–1700; Valiant Soldier 278, c. 1670–1700; Goldsmith Street 19, c. 1690–1720 (scale 1:4, except view of 2442, 1:2).

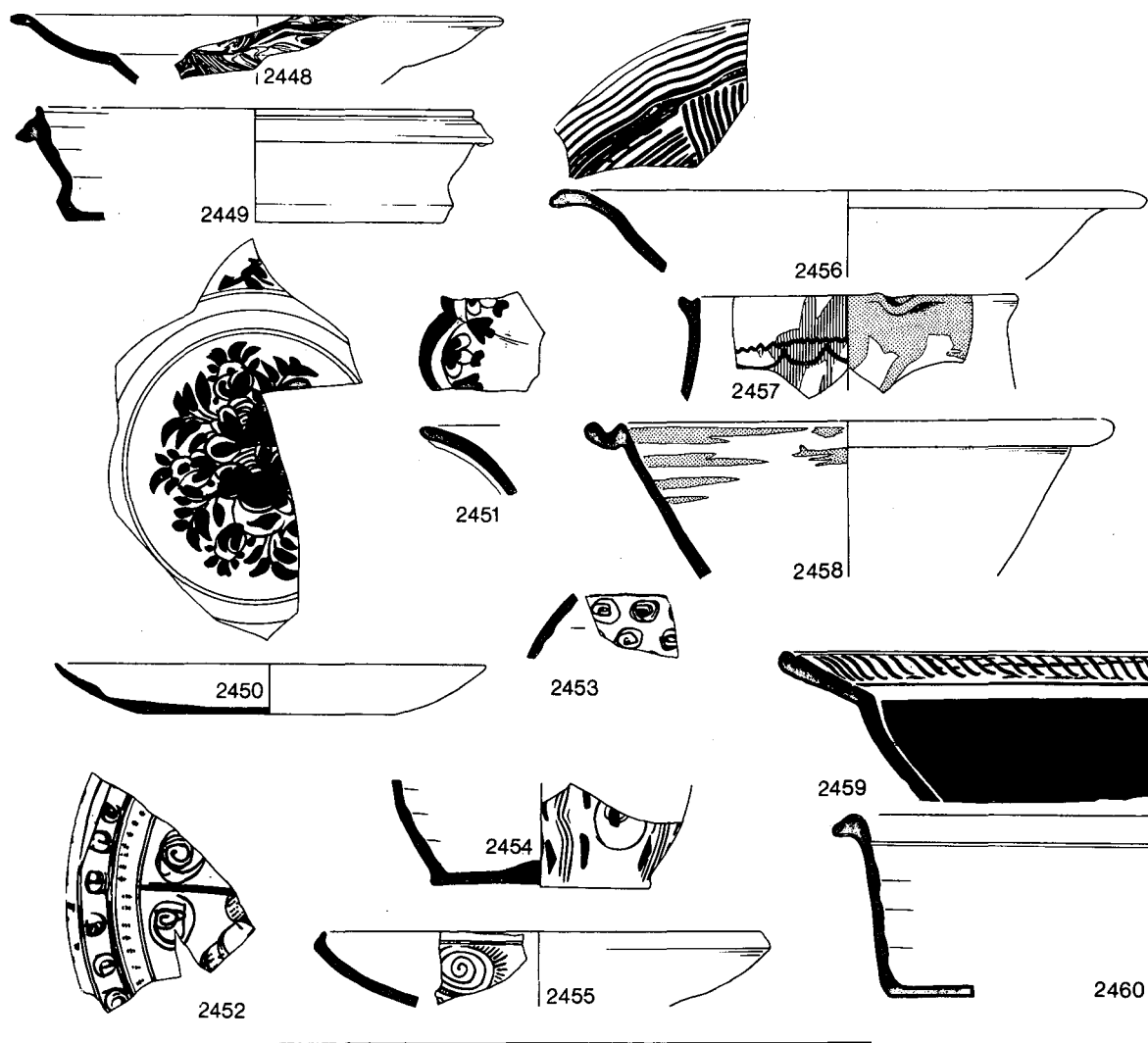

Fig. 110. Rack Street 47 and 141, c. 1690–1720 (scale 1:4).

- surface painted in dark blue with mid blue wash. Dutch, c. 1680.
- 2432–3** Dish sherds with coarse cream-pink fabrics, lead-glazed backs, upper surface painted dull blue (2432) or blue, light green and brown (2433). Dutch, c. 1600–50.
- 2434** Frechen medallion with crowned arms depicting two lions rampant *in chief*.
- 2435** Plain white tin-glazed cup. Probably London, late 17th-century; cf. Bloice 1971, 124, No. 62A.
- 2436–7** North Devon plain type 7 chamber pot and type 3E bowl.
- 2438–40** South Somerset type 4B chafing dish with *int* yellow glazed slip; **2439** sgraffito-decorated dish with patches of copper-green; **2440** type 6A chamber pot.
- Not ill:* N. Devon types 2A, 5, 6, 7, 10; S. Somerset 17th-century types 3A(2), 4B, 8A, 8B, 12, 13.
- Date:* c. 1670–1700.

VALIANT SOLDIER 278 (Fig. 109)

Group from a layer of building rubble with much domestic rubbish.

*Clay pipes:* Type LA small, c. 1650–60; type 22W, c. 1650–80; 3 type 7S, c. 1660–90; 4 type 7B, c. 1660–90; 2 type LB, c. 1670–1700; 3 type L4, c. 1690–1720.

- 2441** Frechen Bellarmine with the top of a crown in the medallion.
- 2442** Staffordshire-Bristol porringer handle. One of a pair, presumably from the same vessel. Fine cream fabric, feathered slip. Moulded decoration in relief on rim, *ill* at half actual size.

- 2443** North Devon bowl, cf. type 3G, with finger impressions on top.
- 2444** South Somerset plate with *int* slip, glazed yellow, line sgraffito and patch of copper.
- Not ill:* Westerwald mauve-painted tankard (cf. Reineking-von Bock 1971, Nos. 581, 588–91), c. 1680–1710; N. Devon gravel-temp types 2A, 2B, 3D, 7, 13; S. Somerset 17th-century types 1E, 3A(3).
- Date:* 1690–1720.

GOLDSMITH STREET 19 (Fig. 109)

Pit group.

*Clay pipes:* CP.84 and Type L1, both c. 1690–1720.

- 2445** Westerwald jug with moulded decoration, painted in blue. Early 17th-century type, old or residual in this context.

- 2446–7** Footed Frechen jugs.
- Date:* c. 1690–1720.

RACK STREET 47 and 141 (Fig. 110)

RS 47: pit group. RS 141: layer with many joining sherds. All vessels are present in RS 47.

*Relations:* RS 47 under RS 20, group of c. 1690–1720 (2496–2503). RS 141 over RS 148 with one clay pipe type L1, c. 1690–1720.

*Clay pipes:* (RS 47) type L1, c. 1690–1720; (RS 141) type LA, c. 1640–60; 6 type L1, 1690–1720.

*Coins:* (RS 141) E.33, 1657–75; E.45, 1672–c. 1700.

*Glass bottles:* (RS 47) base, type 9, c. 1705–20; (RS 141) G.149, c. 1690.

- 2448** North Italian marbled ware dish with *int* marbled red and white slips; plain glazed back.

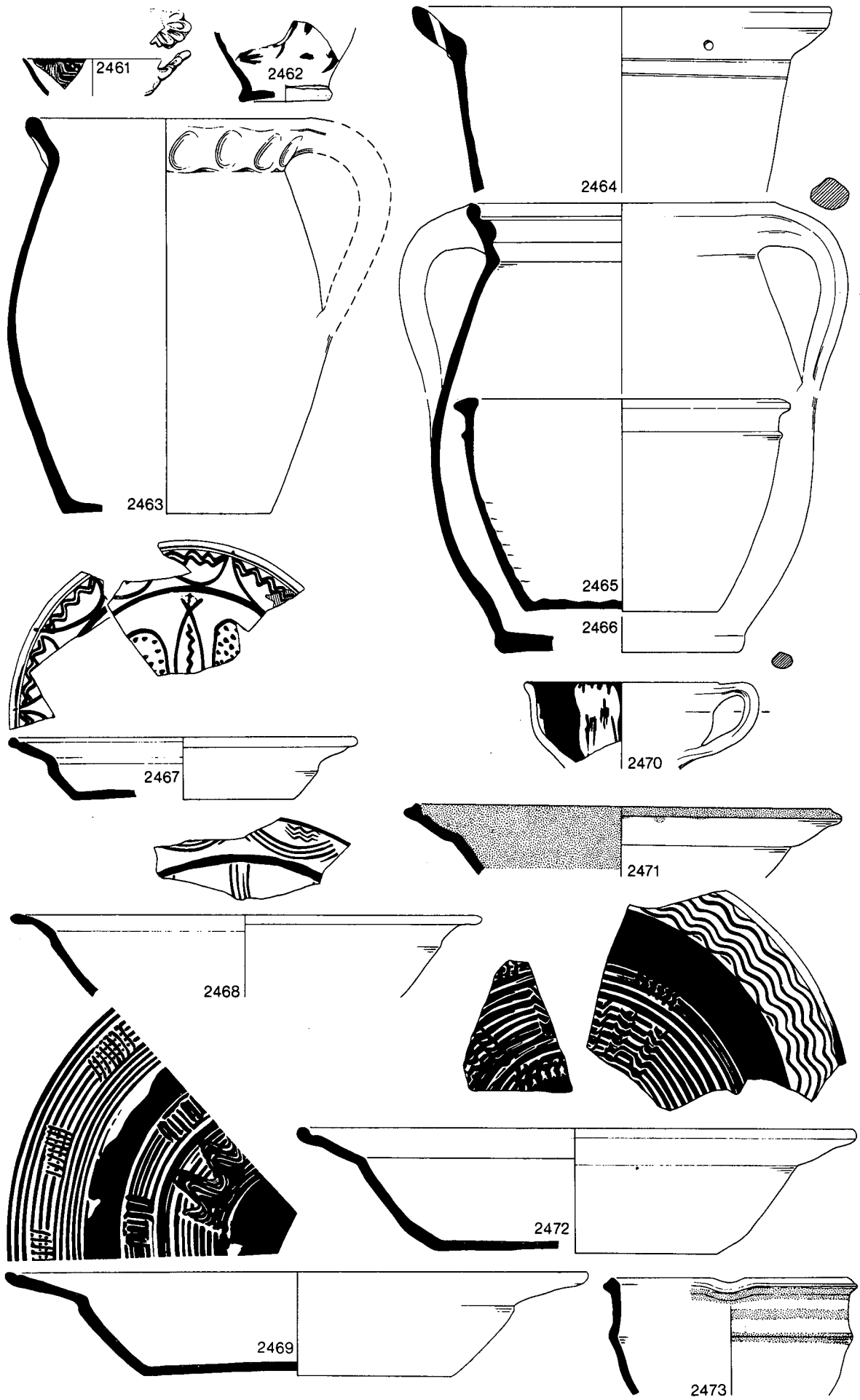

Fig. 111. Bartholomew Street West 133, c. 1690-1720 (scale 1:4).

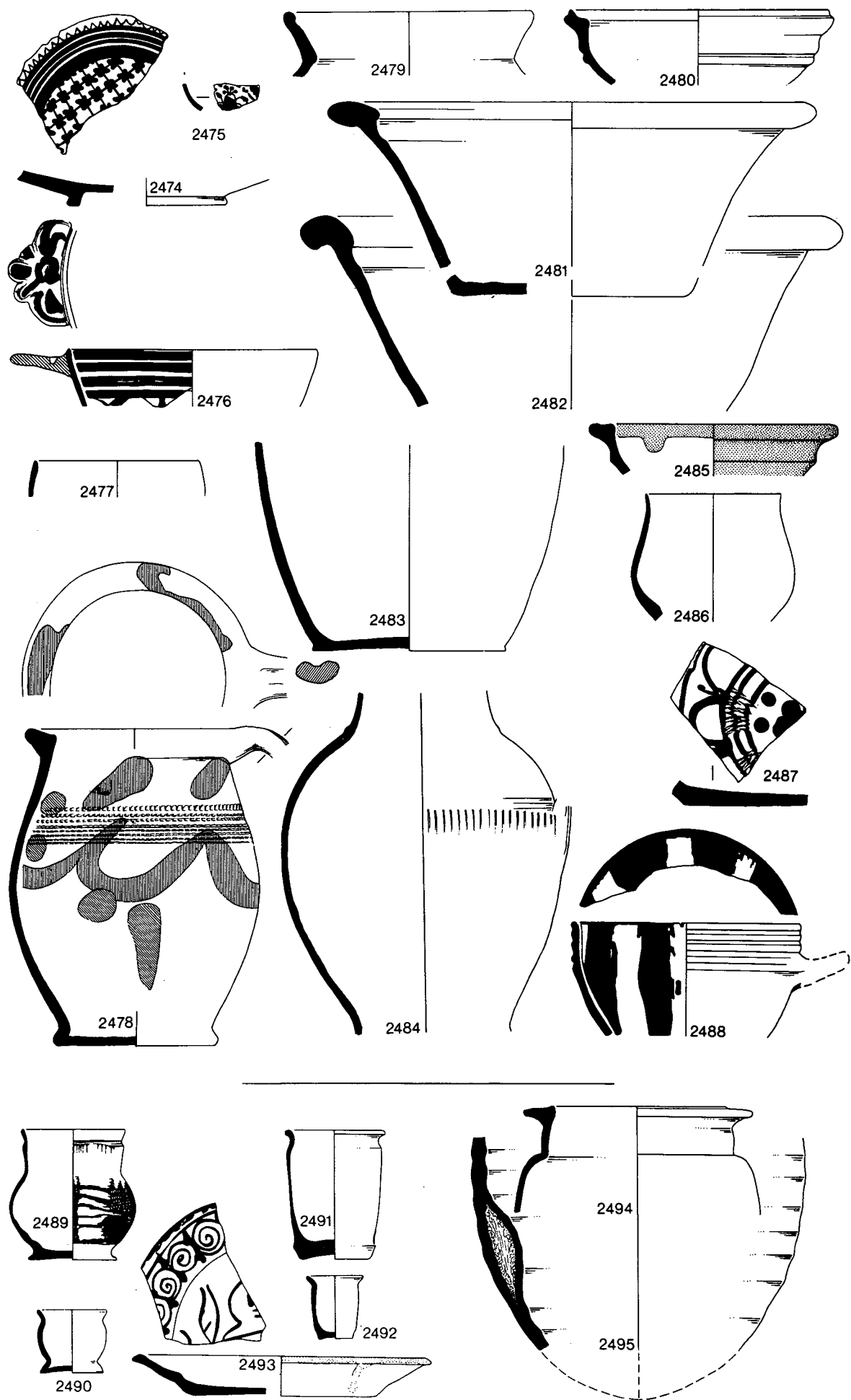

Fig. 112. Rack Street 703; Magdalen Street 100; Goldsmith Street 24, all c. 1690–1720 (scale 1:4).

- 2449** Low Countries redware ?skillet. Fine red fabric, clear thick brown-orange *int* glaze, sooted *ext*.  
**2450-1** Delftware plate with *ext* tin glaze, *int* mid to dark blue painting. **2450** Dutch, c. 1700-15; **2451** with moulded and foliated rim, Dutch, c. 1700.  
**2452-5** North Devon sgraffito-decorated sherds. **2452** type 1A dish; **2453-4** jugs.  
**2456-60** South Somerset 18th-century types. **2456** type 1C dish; **2457** ?jug with pulled rim. *Int* slip glazed yellow with splash of copper-green; **2458** type 3B bowl or colander; **2459** type 1A dish; **2460** type 3G pan, unsooted.

*Not ill:* N. Devon types 3E, 6, 7, 11; S. Somerset types 3D(5), 3E.

*Date:* c. 1690-1720.

#### BARTHOLOMEW STREET WEST 133 (Fig. 111)

Pit group. Large lumps of pipeclay were present in the lower fill of this pit, and pipe kiln debris filled its top. The group is therefore contemporary with pipe-making activity on the site, dated, c. 1690-1720/30 (pp. 280-2).

*Glass bottles:* 3 bodies, type 3 or 4, c. 1655-1670; neck, type 2 or 4, c. 1655-1690; 3 necks, types 8-10, c. 1685-1730; body, type 9, c. 1705-20.

#### *Imports and delftwares*

- 2461** North Italian marbled ware sherd with *int* marbled red and white slips and *ext* glaze. The handle has been formed in a mould; its position in relation to the rim is uncertain.  
**2462** Small delftware cup with thick glossy white *int* and *ext* tin glaze, perhaps lead-glazed over the tin glaze; painted *ext* with a floral pattern. Probably Dutch, c. 1700.

*Not ill:* Delftware plate with 'Chinamen amongst grasses' (cf. **2292**; probably Lambeth, c. 1680-90).

#### *Local wares*

- 2463** Storage jar, source unlocated but probably south-west English. Fabric with rounded red and brown stone inclusions and small quartzite lumps. Orange-green *int* glaze with iron flecks, *ext* glaze on rim.  
**2464-6** North Devon gravel-tempered wares. **2464** cf. **2528**; **2465** type 3C, sooted; **2466** type 11, not sooted.  
**2467-73** South Somerset 18th-century types. **2467** dish with slip, line sgraffito and patches of copper, rich yellow glaze over slip, orange over body; **2468** type 1C dish with slip and combed sgraffito, glazed pale yellow over slip and orange-brown over body; **2469** type 1A; **2470** small type 2C cup with *int* brushed slip, glazed orange over body, pale yellow over slip; **2471** dish with *int* slip, glazed pale yellow; **2472** type 1A; **2473** type 3E.

*Not ill:* N. Devon plain slip type 1C; N. Devon gravel-temp types 2, 3A, 3C(2); S. Somerset types 1D, 4.

*Date:* c. 1690-1720.

#### RACK STREET 703 (Fig. 112)

Pit group.

*Clay pipes:* Types L.1, L.4 (4 bowls), c. 1690-1720.

#### *Imports and non-local English*

- 2474-6** Delftwares. **2474** dish with lead-glazed back, cf. Korf 1973, 70, Fig. 80. Dutch, c. 1600-50; **2475** sherd with floral pattern in mid blue, probably English, c. 1700; **2476** porringer sherd with *ext* lead glaze, Dutch, c. 1600-50.  
**2477** Surrey-Hampshire white ware with mid green *int* glaze.  
**2478** Chamber pot, source unknown. Sandy white ware, rouletted band on body, splashes of green and red-brown under *ext* pale yellow glaze. *Int* glaze.

*Not ill:* Carrot olive jar; N. Italian marbled sherd with red-and-white slips; delftware *bleu de Nevers* sherd, probably London, c. 1680-90.

#### *Local wares*

- 2479-83** North Devon gravel-tempered wares. **2481-2** forms 3A, 3G, sooted *ext*.  
**2484-8** South Somerset 18th-century types. **2484** and **2486** black-glazed; **2487** type 1D, feathered double slips; **2488** cup with horizontal handle, *int* brushed slip and green-brown glaze over body.

*Not ill:* N. Devon types 1C, 3C, 3D, 11; S. Somerset types 1A, 2A(2) 3D(10), 5, 13.

*Date:* c. 1690-1720.

#### MAGDALEN STREET 100 (Fig. 112)

Pit group.

*Clay pipes:* 5 type L1, c. 1690-1720.

- 2489** Bristol-Staffordshire yellow slipware cup. Area of handle absent.  
**2490** Plain tin-glazed drug jar.  
**2491** Surrey-Hampshire drug jar.  
**2492-3** South Somerset drug jar and dish with *int* slip and sgraffito decoration.

*Date:* c. 1690-1720.

#### GOLDSMITH STREET 24 (Fig. 112)

*Clay pipes:* Type LA, c. 1650-70; type LC, c. 1660-90; 5 type L1, c. 1690-1720.

*Glass bottles:* Base, type 9, c. 1705-20; rim; cf. types 6-10, c. 1690-1730.

- 2494** Normandy stoneware ?cooking pot (cf. Barton 1977, *passim*).  
**2495** Spanish olive jar with *ext* slip, *int* glaze, blistered in firing.

*Not ill:* Westerwald chamber pot; Bristol-Staffs pressed plate.

*Date:* c. 1690-1720.

#### RACK STREET 20 (Fig. 113)

Group from a layer.

*Relations:* Under RS 19 with pipes of types L1-3, c. 1690-1720; over RS 47, group of c. 1690-1720 (**2448-60**).

*Glass bottles:* Base, type 4 or 6, c. 1675-1710; 2 tops, type 9, c. 1705-20.

- 2496** Westerwald mug with applied [. . .] R stamp and incised decoration, painted in blue and purple; cf. Reineking-von Bock 1971, Nos. 577-89, c. 1690-1720.  
**2497** Frechen Bellarmine with a degenerate version of crowned arms of Amsterdam with lion supporters.  
**2498** Delftware plate with white *int* and *ext* glaze. Foliage outlined by fine black lines and infilled in mid blue. Dutch, c. 1700.

*Not ill:* 2 olive jars, one globular; Westerwald chamber pot sherd.

- 2499-2503** South Somerset 18th-century types. **2499** bowl with *int* slip and mottled copper-green glaze; **2500** type 2B cup; **2501** black-glazed pedestal cup; **2502-3** types 3G and 3F.

*Date:* c. 1690-1720.

#### FRIARS WALK 8 (Fig. 113)

Pit group; fill possibly continuous with FW 18 (below).

*Clay pipes:* 3 type L1, c. 1690-1730.

*Glass bottles:* Base, type 4 or 6, c. 1675-1710; 2 bodies, type 7 or 8, c. 1685-1715.

- 2504** Small delftware cup with all-over tin glaze with bluish-green tinge. Imitation Chinese design, the flowers outlined in dark blackish-blue, painted in grey-blue. '10' painted on base inside foot-ring. Foot-ring markedly abraded. Dutch, c. 1680.  
**2505** Sherds from a delftware ?jug. *Int* and *ext* white tin glaze, floral design outlined with fine black lines, infilled with blue wash. English, probably London, c. 1680-90.

**2506-7** Bristol yellow slipware cups.

*Not ill:* N. Devon gravel-temp types 3A, 3C, 4; S. Somerset 18th-century types 1A, 2A, 2B, 3D(2).

*Date:* c. 1690-1720.

#### FRIARS WALK 18 (Fig. 113)

Pit group; fill possibly continuous with FW 8 (above).

*Clay pipes:* 3 type L1, c. 1690-1730.

- 2508** North Devon gravel-tempered cistern with *int* glaze.  
**2509** South Somerset ?jug rim with pulled lip. *Int* slip and copper mottling.

*Not ill:* N. Devon gravel-temp types 2, 3C, 3F; S. Somerset 18th-century types 1A, 2, 3D.

*Date:* c. 1690-1720.

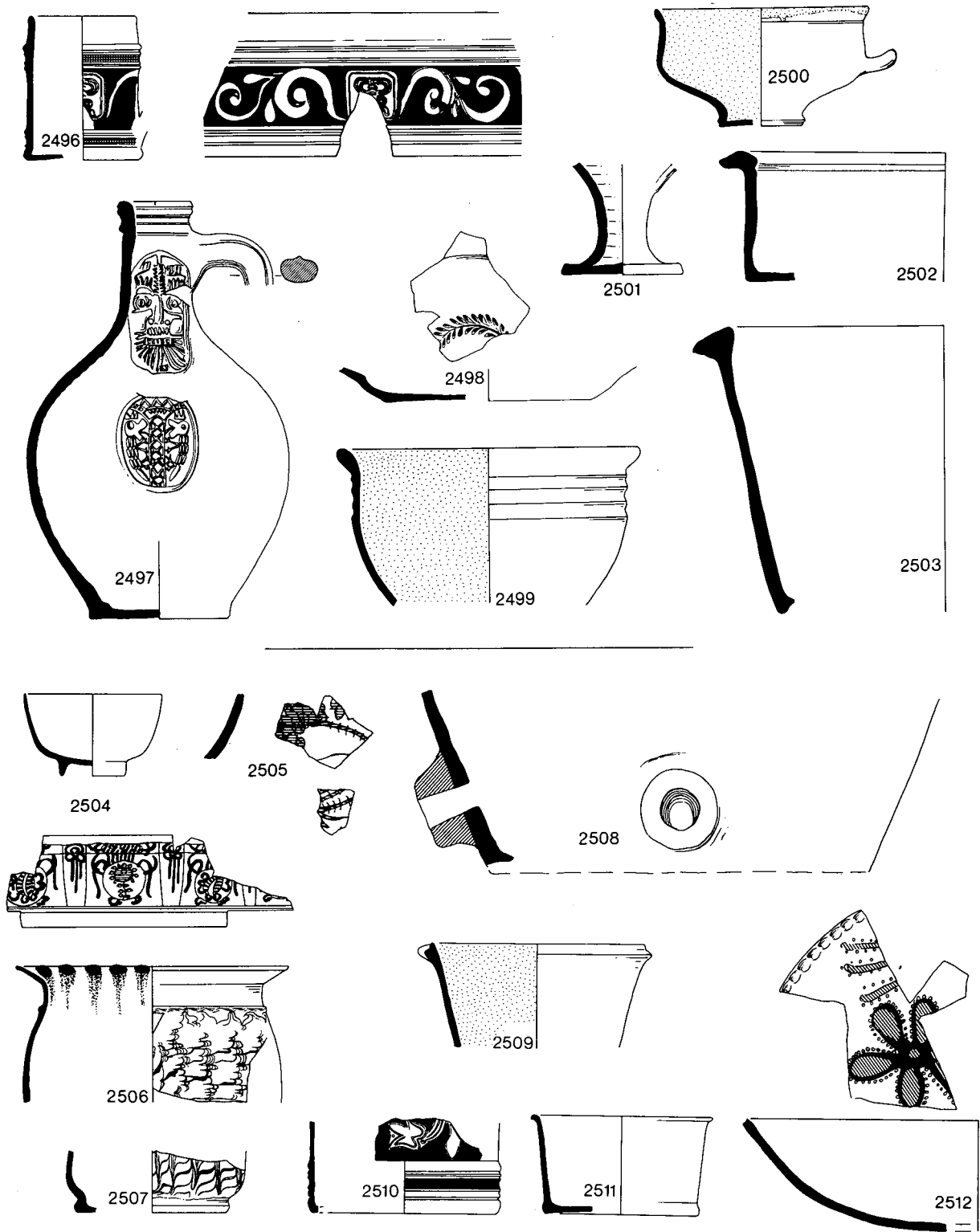

Fig. 113. Rack Street 20; Friars Walk 8, 18, 14; all c. 1690–1720 (scale 1:4).

FRIARS WALK 14 (Fig. 113)

Pit group.

Clay pipes: 1 type 10B, c. 1710–40; 3 type L1, c. 1690–1720; 1 cf. type LD, c. 1690–1730.

**2510** Westerwald tankard with moulded flower, incised leaves and stem.

**2511** Bristol ?cup. Cream-red fabric, dark 'treacle-brown' int and ext glaze, thick at base, with iron-bleeding.

**2512** Bristol-Staffordshire press-moulded plate. Dots moulded in relief with light and dark brown slips over.

Not ill: Carrot olive jar sherd; Westerwald chamber pot; S. Somerset 18th-century types 1A, 2, 3D, 14.

Date: c. 1690–1720.

FRIARS GATE 107 (Fig. 114)

Group from a thick dark brown loam, possibly a garden soil. Clay pipes: Type LA, c. 1640–60; type LC, c. 1650–80; type LB, c. 1660–90; 19 type L1 and L4, c. 1690–1720.

Glass bottles: Base, type 4, c. 1675–90; base cf. type 6, c. 1700; 2 tops, type 6 or 11, c. 1700–30.

Imports

**2513–14** Chinese porcelain, painted blue. **2513** delicate saucer-dish, K'ang Hsi, c. 1690–1720 (see Pl.2); **2514** small dish with high kicked base, possibly Chinese provincial, 17th- or early 18th-century (see Pl.2).

**2515** Ligurian maiolica dish sherd. Thick tin glaze, heavily crazed, painted dark and light blue, orange and yellow with outlines in black.

**2516–17** Small North Holland slipware bowls. **2516** with



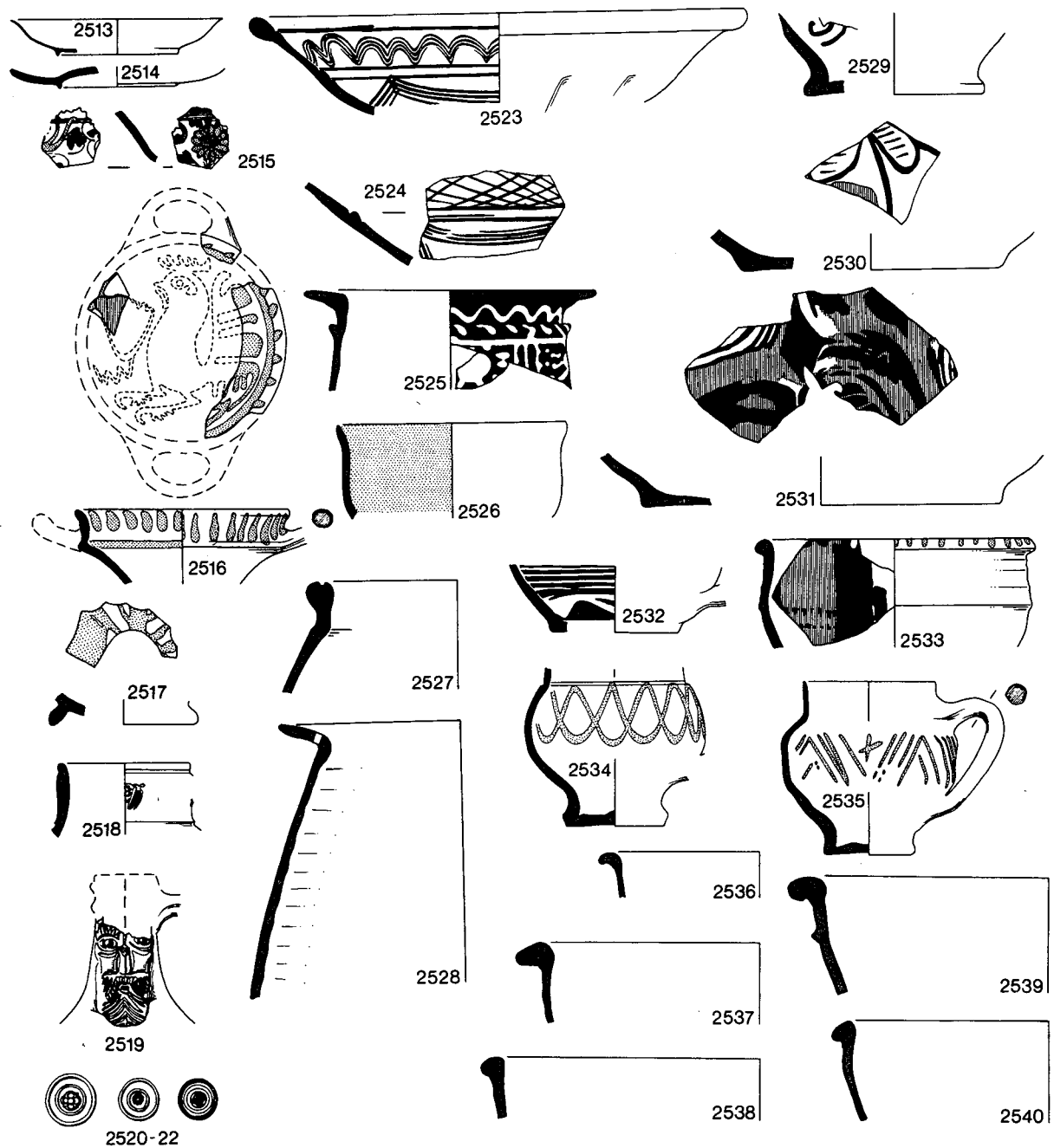

Fig. 114. Friars Gate 107, c. 1690-1720 (scale 1:4).

parts of a cockerel (Hurst *et al.* 1975, type 1) and the edge of a date [ . . . ]7; **2517** with part of a ?floral design (*ibid.*, type 3), heavily sooted *ext*.

**2518-19** Frechen stonewares. **2518** with impressed stamp;

**2519** Bellarmine neck.

**2520-2** Westerwald jug stamps, at half actual size, from late 17th-century jugs as **2320**, **2322**.

*Not ill:* Chinese porcelain dish, Wan Li, c. 1600 (Pl.1); sherds of N. Italian marbled slipware bowl with *ext* glaze and blotchy green, black, light brown and white *int* slips.

*Local wares*

**2523-8** North Devon wares. **2523-4** sgraffito-decorated dishes, type 1C; **2525** trailed slipware chamber pot, type 7; **2526** plain slipware cup, type 12A; **2527** gravel-tempered jar, glazed *int*; **2528** unglazed gravel-tempered vessel. Function uncertain but possibly a flowerpot; P. Perremans has drawn attention to Dutch paintings showing flowerpots with several holes in their rims which accommodated trellises (Perremans, pers. comm.). The vessel may alternatively be a 'sparrow-pot', again with a twig fixed in the hole; sparrows nesting in such vessels were trapped and eaten (Brears 1974, 104).

**2529-40** South Somerset wares, 18th-century types. **2529-30** sherds with *int* slip, glazed yellow, and sgraffito decoration; **2531** dish with copper green in trailed slip; **2532** cup with *int* slip, glazed yellow; **2533** sherds decorated as **2531**; **2534-5** cups with *ext* trailed slip lines, **2534** with rather gritty fabric, source uncertain; **2536-40** plain coarseware bowls.

*Not ill:* N. Devon sgraffito type 1A(2), plain slip type 5, gravel-temp types 3C(3), 3D(2), 7, 11(3).

*Date:* c. 1690-1720.

CATHEDRAL CLOSE 19 (Fig. 115)

Layer of rubbish deposited over the Cathedral Close graveyard. *Clay pipes:* 12 type L1, c. 1690-1720; type LC, c. 1690-1720; type 10B, c. 1700-40; type 12S, c. 1700-20.

*Glass bottles:* 13 necks as types 8-10, c. 1685-1730; 4 bodies as types 7 or 8, c. 1685-1715; neck type 11, c. 1710-30.

*Imports and non-local English*

**2541** Plain ?Frechen jug, probably residual, with even bronze-brown glaze.

**2542-3** Westerwald jug rim and base with incised floral designs, cf. Reineking-von Bock 1971, Nos. 540, 543, end of 17th- or early 18th-century.

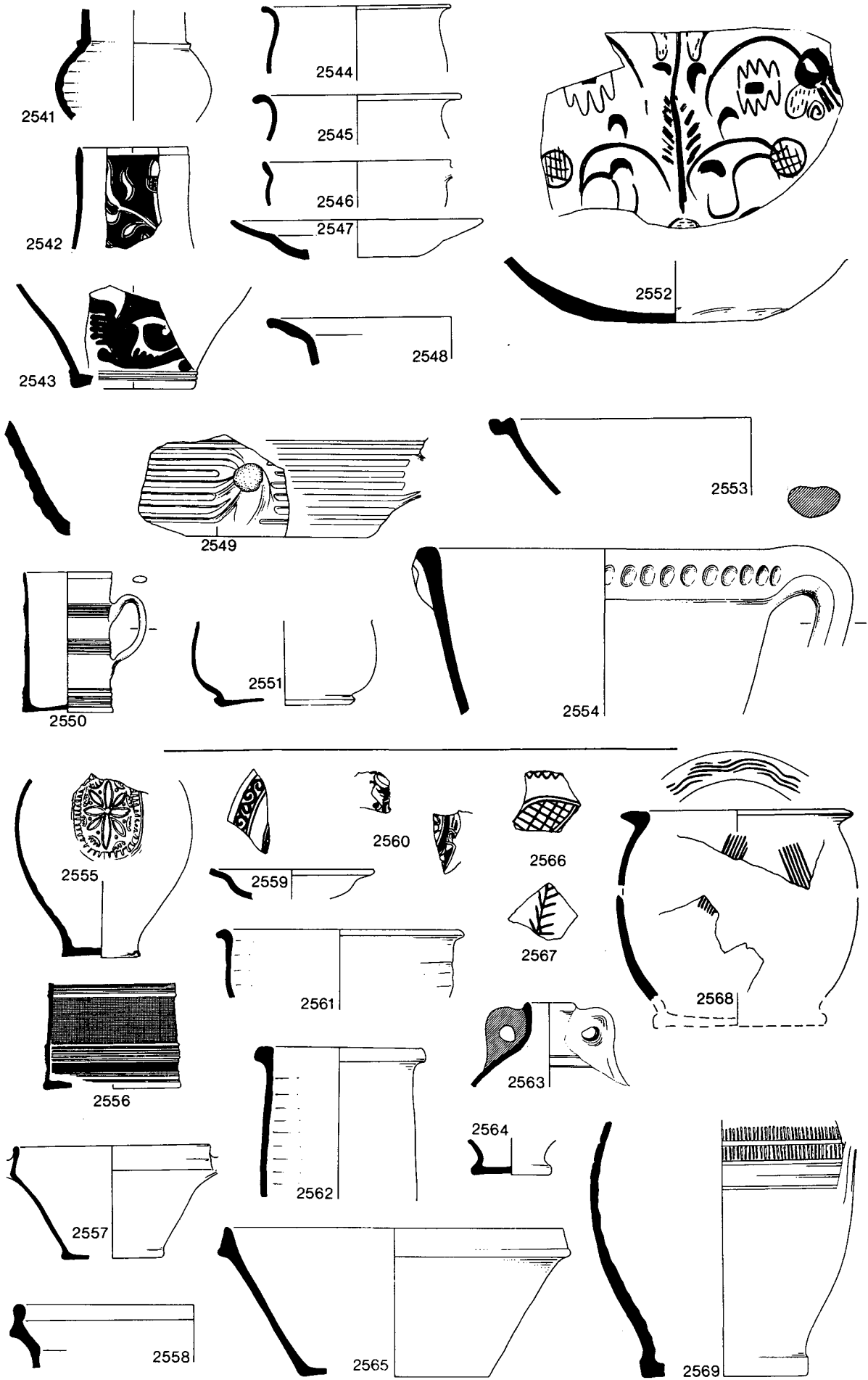

Fig. 115. Cathedral Close 19, c. 1700–20; Goldsmith Street 77–8 and L.13–14, c. 1680–1720 (scale 1:4).

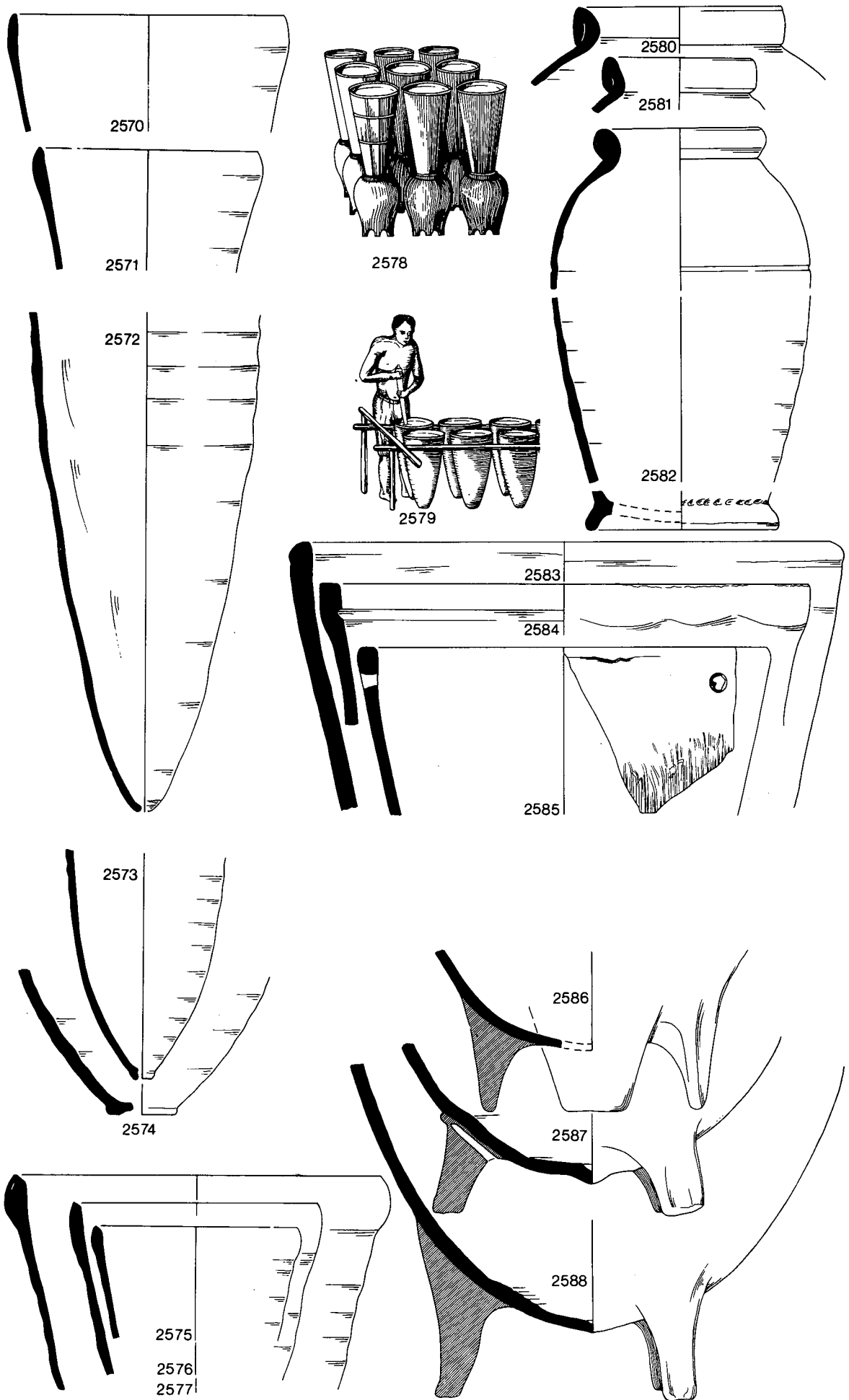

Fig. 116. Sugar refining wares from Goldsmith Street (scale 1:4) with sketches 2578-9 showing the use of comparable vessels in 18th-century France.

- 2544-8** Plain delftware. **2544-5** chamber pots; **2546** cup; **2547** plate (diam. uncertain); **2548** ?bowl or flower-pot sherd, cf. **2848**. These are probably all English.
- 2549** Low Countries redware with *int* and *ext* orange glaze.
- 2550-51** Bristol half-pint tankard and cup. Fine fawn fabric, *int* and *ext* thick treacle-brown glaze with iron-bleeding.

*Not ill:* Porcelain vessel with outlining in gold on a blue field, c. 1700-20; Italian marbled ware; sherd from Spanish green-glazed flanged bowl; globular olive jar; Westerwald chamber pot as **2672**; Bristol-Staffs stoneware.

*Local wares*

- 2552-3** North Devon sgraffito-decorated dish, form 1A; and gravel-tempered bowl.
- 2554** Totnes-type vessel with *int* glaze.
- Not ill:* N. Devon plain slip type 1C; N. Devon gravel-temp types 2A, 3A, 3C(2), 6, 7, 11; S. Somerset 18th-century types 1A(4), 1C, 1D, 2A/B, 3C, 3D, 3F(2), 5, 10, 12B, 13(2).
- Date:* c. 1700-20.

GOLDSMITH STREET 77-8 and L. 13-14 (Fig. 115)

Group associated with sugar-refining wares (below).

*Clay pipes:* All deposits contained types LB, LC, L1 of c. 1670-1720; the predominant type is L1 (among a total of 54 bowls).

*Glass:* G.154 and 173.

*Imports and non-local English*

- 2555** Frechen Bellarmine with rosette medallion.
- 2556** Westerwald tankard with central mauve band; cf. Reineking-von Bock 1971, No. 576, late 17th-century.
- 2557** Low Countries yellow- and green-glazed bowl. Fine sandy white ware, rich even green *ext* glaze, crazed *int* yellow glaze; cf. wares of this class from Plymouth (Gaskell Brown 1979, 46).
- 2558** Low Countries redware with *int* patchy orange-brown glaze.
- 2559** Sherd of a small delftware dish. Plain tin-glazed back, mauve line on rim *ext*, painting on front in mid blue with a bright yellow spot. English, c. 1700.
- 2560** Fragments of a delftware vessel with a cartouche painted pale and dark blue. Late 17th-century, origin uncertain.
- 2561** Surrey-Hampshire whiteware bowl with *int* brown glaze.
- 2562** Jar, origin uncertain. Fine pale cream fabric, *int* patchy yellow-brown glaze.
- 2563** Top of a standing costrel. Light grey fabric, *ext* thick green-brown glaze. Origin uncertain, not local.
- 2564** Fine cup base, origin uncertain. Fine sandy white fabric with sparse quartz inclusions up to 1 mm. *Int* and *ext* yellow glaze with splash of copper-green.

*Not ill:* Scraps of a foliated dish rim painted with 'Chinamen in landscapes', Lambeth type — all the dated examples are of 1684 (*ex inf.* the late L. L. Lipski); rim as **2451**, Dutch, c. 1700; carrot olive jar; Westerwald chamber pots; N. Holland slip; Merida-type, *thin-sectioned*, fabric 1 (p. 145).

*Local wares*

- 2565** North Devon type 3F bowl, sooted *ext*.
- 2566-7** Sherds from South Somerset dishes with *int* slip glazed yellow, and sgraffito decoration glazed red.
- 2568** South Somerset 17th-century type chamber pot with all-over slip glazed yellow and line sgraffito. Splashes of black glaze from an adjacent vessel in kiln.
- 2569** Base of a South Somerset 17th-century type 5B jug with a band of rouletting and mauve-black glaze.

*Not ill:* N. Devon gravel-temp types 2A(6), 3(5); S. Somerset 17th-century types 3A, 8A(3), and 18th-century types 1A, 3D(10), 4, 12B(2).

**2570-88** Sugar-refining wares (see pp. 138-41).

*Date:* c. 1680-1720.

MAGDALEN STREET 7 (Figs. 117-18)

This groups comes from the top 3 m of the fill of a large well in the garden of 44-6 Magdalen Street. The property was a large

one, and between 1713 and 1740 was owned by John Essington, a wealthy individual, although it is unclear whether he lived here (forthcoming report in a future volume of E.A.R.).

*Clay pipes:* Type L1, c. 1690-1720; 2 type 12B, c. 1700-40; 3 local types, c. 1720-40; CP.57-9, c. 1720-50.

*Glass bottles:* 3 types 8 or 9, c. 1685-1720; type 10, c. 1720-30.

*Imports and non-local English*

- 2589-90** Chinese porcelain cups with characters on both *int* and *ext* of bowl. Rather crude designs, c. 1680-1725.
- 2591-5** Delftware. **2591** cup with plain white *int* and *ext* painting in blue, red and green, London or Bristol, c. 1720-40 (for similar rim decoration see Ray 1968, Fig. 73, No. 142, Bristol, c. 1725-40); **2592** plate with plain back, front painted in pale blue, Bristol or Liverpool, c. 1725-40; **2593-5** plain plate, chamber pot and bowl, all probably English.
- 2596** Bristol-Staffordshire yellow slipware with *int* dark slip coat, glazed brown. Blobs of white slip, glazed yellow, over dark slip. Yellow-glazed *ext*.
- 2597-9** Westerwald wares with incised designs and blue surrounds. **2597-8** tankards, **2598** after 1714; **2599** jug. Early 18th-century types.
- 2600** Bristol-Staffordshire yellow slipware sherd from a large cup. Trained dark brown slip, jewellery in white slip. The fabric is typical of Bristol, but there is not yet any evidence of the production of such elaborate wares there (*ex inf.* D. Dawson).
- 2601-2** Bristol-Staffordshire stonewares. **2601** tankard with *ext* brown iron wash (a similar sherd in the group has an incuse GR monogram); **2602** jug with the edge of a pulled spout.
- 2603-5** Bristol-Staffordshire earthenware tankards with buff fabrics, thick treacle-brown glaze.

*North Devon wares*

**2606-7** **2606** plain type 2A jug; **2607** bodysherd with *int* sooting and *ext* glaze which appears to come from a chill. (Reconstruction shows one such vessel now in the Pilton Art Centre, Barnstaple).

*South Somerset (18th-century types)*

- 2608-9** Dishes with double slips, feathered and glazed.
- 2610-12** Type 1A dishes.
- 2613-15** Type 1B dishes with a distinctive broad-blade style of sgraffito decoration. Glazed speckled light green over body, speckled orange over slip. Examples are known from the Donyatt kilns (Coleman-Smith and Pearson 1970, Fig. 1), and others bearing the date 1725 are in the Fitzwilliam Collection, and in Exeter Museum (Rackham 1935, 13, No. 72, wrongly attributed; Exeter Museum Acc. No. 253/1976).
- 2616-27** Plain wares. **2616** type 5 jug with slip bands; **2617** type 6 chamber pot; **2618** ?type 4 bucket-handled pot; **2619** type 3D; **2620** bowl; **2621** type 3G; **2622** type 3D; **2623** type 2B cup with *int* slip, speckled with copper; **2624** small bottle with *ext* slip, speckled with copper; **2625** type 8; **2626** type 11; **2627** type 3B.

*Not ill:* S. Somerset types 1A (2), 1B(2), 2B, 3D(10), 10(3+), 13.

*Date:* c. 1720-40.

HIGH STREET TOPSHAM, 1977 (Fig. 119)

Group excavated from a midden at SX 9641 8850. There was no sign of earlier occupation in the area.

*Clay pipes:* 2 type L1, c. 1690-1720.

*Glass bottles:* Body, type 7, c. 1685-1715; 2 bases, type 9, c. 1705-20; 2 bases, type 11, c. 1710-30; G.172 and 176.

*Imports and non-local English*

- 2628** Delftware plate with moulded rim, painted mid blue. English, possibly Bristol, c. 1700-15.
- 2629** North Holland slipware bowl sherd.
- 2630** Low Countries redware cooking pot; pinched handle, sooted base. The type has tripod feet (cf. Clarke and Carter 1977, 272, No. 284).
- 2631** Bowl with horizontal handle. Sandy red fabric, clear green-brown glaze over *int* and most of *ext*. Probably not local.
- 2632-3** Staffordshire or Bristol press-moulded plates.
- 2634** Bristol stoneware. An unusual form; D. Dawson has suggested that this is perhaps the end of a barrel

costrel. Grey-white fabric, grey-white glaze on base, brown iron wash on body.

*Not ill:* Globular olive jar; Westerwald chamber pots as 2602.

*Local wares*

**2635-7** South Somerset 18th-century types. **2635** chamber pot; **2636** bowl with *int* slip and copper-green mottling; **2637** type 15 pan, not sooted.

*Not ill:* S. Somerset types 1A(3), 3D, 6(3), ?8, 13.

*Date:* c. 1700-30.

FRIARS GATE 101 (Fig. 119)

Group from a layer.

*Clay pipes:* Bristol types 10-12, c. 1700-40.

*Imports and non-local English*

**2638** Delftware plate painted in blue bearing the date 17[. . .]. This is the fourth in a set reading (1) What is a merry man (2) Let him do what he can (3) To entertain his guests (4) With wine and Merry Jest (5) But if the Wife do frown (6) All merriment goes down. Sets of Merryman plates with this type of border bear dates between 1734 and 1752. They were probably made in all English delftware factories (Ray 1968, 150).

**2639** Delftware vase, perhaps two-handled, painted in dark blue with a plain *int* tin glaze. Painting on neck similar to some Dutch pieces, but body painting typically English. Source uncertain, c. 1700-5 or later.

**2640-1** Westerwald jug medallions. **2640** with AR monogram, after 1702; **2641** with crowned GR monogram, birds in branches and cherub, after 1714 (cf. Reineking-von Bock 1971, No. 545, possibly from same stamp). Both have incised decoration on body.

**2642** Frechen Bellarmine neck.

**2643-5** Plain white Staffordshire salt-glazed stonewares.

*Not ill:* Chinese porcelain, c. 1745-65.

*Local wares*

**2646-7** South Somerset 18th-century wares. **2646** bowl with trailed slip; **2647** type 3D.

**2648-9** North Devon gravel-tempered wares.

*Not ill:* N. Devon gravel-temp type 2A(2); S. Somerset types 1A(3), 1B, 1D, 2A/2B, 3D(7), 5(2), 6, 10(3).

*Date:* c. 1740-60. There is no creamware in this group.

GOLDSMITH STREET 214 (Fig. 120)

Fill of a small cellar fronting Goldsmith Street.

*Clay pipes:* Type LC, c. 1660-90; 14 plain type 10B/14S with thin bowls and stems, c. 1740-60.

*Glass bottles:* Type 13 base, c. 1730-50; type 14 base, c. 1740-60; top, type 8-11, c. 1685-1730; 12 tops, types 13-15, c. 1730-70; top, type 15, c. 1750-70; **G.160-1**.

*Delftwares* (attributions by M. Archer)

**2650** Sherd from a large dish with plain white back, front painted in greyish-blue with outlining in black. Dutch, c. 1680.

**2651** Bowl rim painted in mid blue. London or Bristol, c. 1700-25.

**2652** Plate sherd with tangled floral design in mid blue. Not identified, date uncertain.

**2653** Plate rim with mid blue painting. Possibly Dutch, ?c. 1700-20.

**2654** Sherd from a flat plate painted in bright red, yellow, blue and green. Dutch, c. 1720.

*Not ill:* Sherd with manganese mauve 'cracked ice' pattern. Bristol, c. 1740-50.

*Other imports and non-local English*

**2655** Degenerate Frechen Bellarmine face.

**2656** Westerwald jug base. Pale grey-fawn fabric, *ext* pale grey salt glaze with blue tinge.

**2657** Jug neck of Nottingham stoneware type; underfired cream earthenware body, applied white quartz band. Metallic brown sheen.

**2658-9** White Staffordshire salt-glazed stonewares, **2658** with rouletted or stamped circular pattern and 'scratch-blue' decoration, c. 1740-70 (Mountford 1971, Pl. 167).

**2660** Bristol-Staffordshire press-moulded plate with marbled light brown, black and white slips.

*Not ill:* Blue-and-white porcelain, c. 1725-50, some perhaps late

in this range; Whieldon-type agate wares; no creamware.

*Local wares*

**2661-8** North Devon plain slipware plate (**2661**), gravel-tempered bowls, and (**2666**) jug.

**2669-71** South Somerset 18th-century type 2D; type 1 with marbled slips; and type 1A.

*Not ill:* N. Devon slip type 5; N. Devon gravel-temp types 2A(6+), 3A, 3C, 11 (2); S. Somerset types 1A (16 including one sooted *ext*), 2A/2B(7), 3D(34), 3F(2), 4, 6(10), 7, 10(15).

*Date:* c. 1740-60.

FRIARS WALK 9 (Fig. 121)

Pit group.

*Clay pipes:* Type 23G, c. 1750-60; cf. type L1, but much thinner bowl, ? c. 1730-50.

*Glass bottles:* Complete type 14, c. 1740-60; type 15 base, c. 1750-70.

*Imports and non-local English*

**2672** Westerwald chamber pot with applied lions and incised rosettes, outlined in blue.

**2673** Plain white tin-glazed chamber pot. English, 18th-century.

**2674-6** Staffordshire white salt-glazed stonewares, **2676** with enamel colours in green, yellow and red, outlined in black. After c. 1750 (Mountford 1971, 57); probably c. 1750-60 (cf. *ibid.*, Pl. 179).

**2677** Bristol-Staffordshire yellow-glazed slipware cup, two handles present.

**2678** Yellow-glazed slipware cup, origin uncertain. Rather sandy off-white fabric, poorly fitting pale yellow glaze, much of which has peeled from the body. Trailed slip, largely decayed. D. Dawson believes that this is of much poorer quality than the usual Bristol products and was not made there.

*Not ill:* Staffordshire cup sherd in agate ware, fabric as Charleston 1968, 261, No. 741, c. 1740.

*Local wares*

**2679** Plant pot in a sandy red ware.

**2680-1** Dish sherds with a dark red fabric, *int* glazed red-brown, with trailed slip glazed dark yellow. This type is not known at Donyatt; it probably comes from one of the other coarseware production centres in the South-West. These are currently the only stratified finds of the type from Exeter.

**2682** South Somerset type 3D bowl.

**2683** As **2680-1**.

**2684** As **2679**.

**2685** Large South Somerset bowl with *int* brown glaze.

*Date:* c. 1750-70.

TRICHAY STREET 322 (Fig. 121)

Pit group.

*Clay pipes:* 2 bowls type 14S, c. 1720-50.

*Glass:* **G.155-9**; **G.179**, c. 1740-60.

*Imports and non-local English*

**2686-8** Chinese porcelain tea bowls painted blue, **2686** with brown rim, **2688** with moulded sides and rim.

**2689** Chinese porcelain saucer-dish with moulded lotus panels below rim, painted blue.

**2690** Plain English delftware chamber pot, 18th-century.

**2691** Chinese porcelain saucer-dish with a landscape scene painted blue.

**2692** Complete Bristol yellow slipware cup.

*Date:* c. 1740-60.

BARTHOLOMEW STREET EAST 191 (Fig. 121)

Pit group.

*Clay pipes:* **CP.119-21**, c. 1730-50.

*Glass:* **G.162-3**, **177-8**, c. 1710-30.

**2693-5** Bristol yellow slipware cups.

*Date:* c. 1730-50.

BARTHOLOMEW STREET EAST 4 (Fig. 121)

Pit group.

*Clay pipes:* As **CP.119-21**, c. 1730-50.

**2696-7** Delftware plates, **2696** painted with 'mimosa' pattern in bright blue. Bristol, c. 1730-50.

**2698** Bristol-Staffordshire grey stoneware with white slips and brown rim.

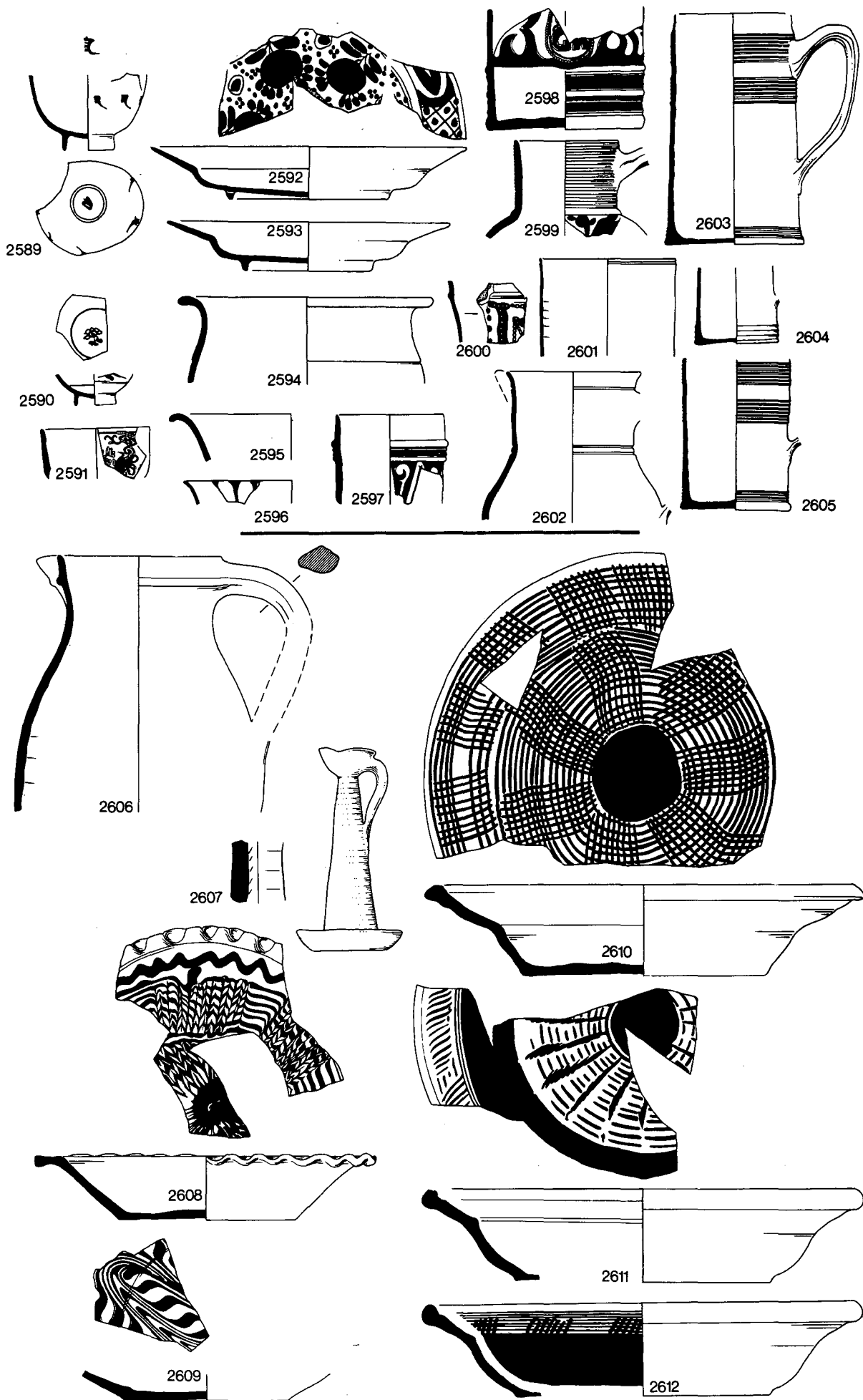

Fig. 117. Magdalen Street 7, c. 1720-40 (scale 1:4).

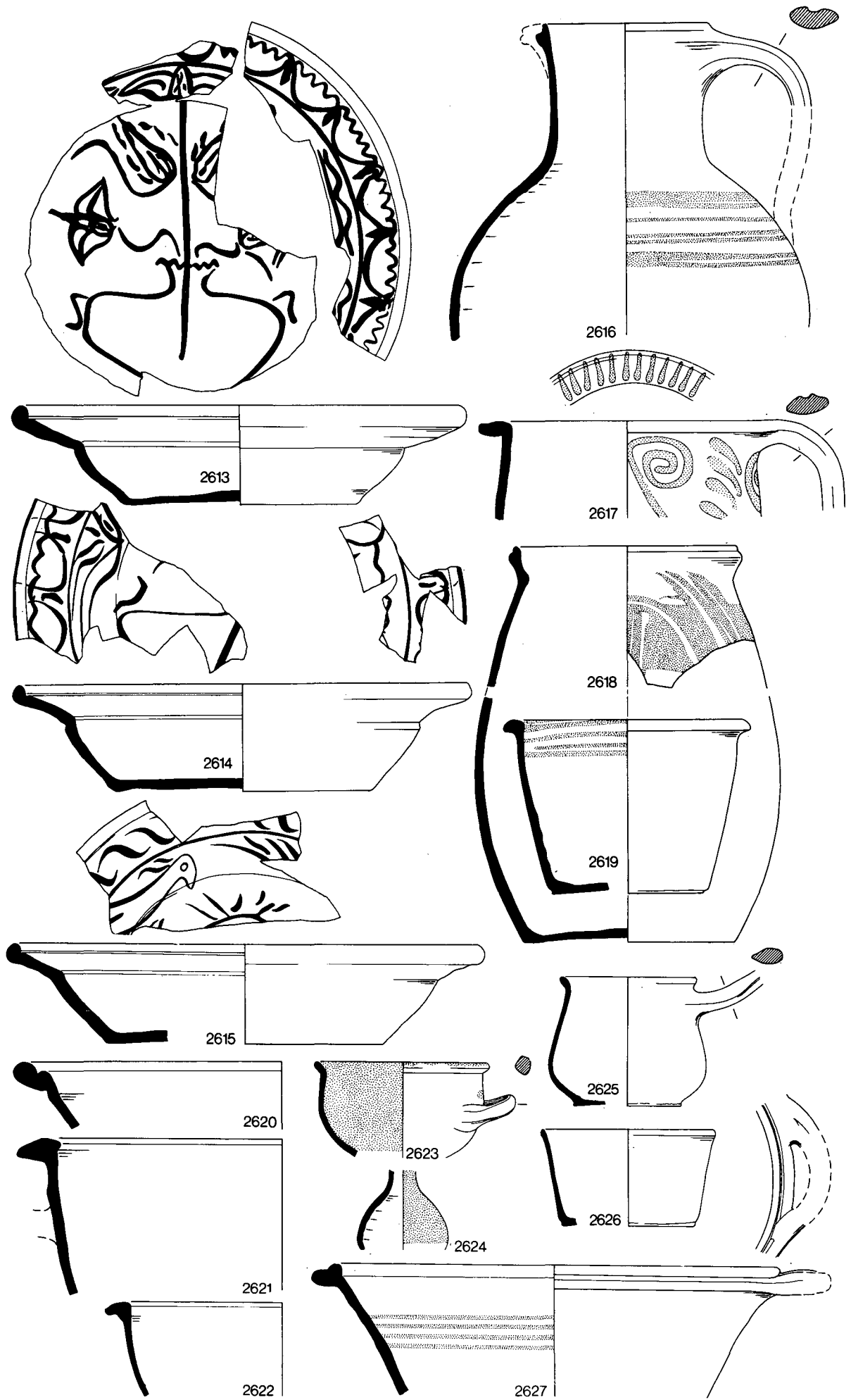

Fig. 118. Magdalen Street 7, c. 1720-40 (scale 1:4).

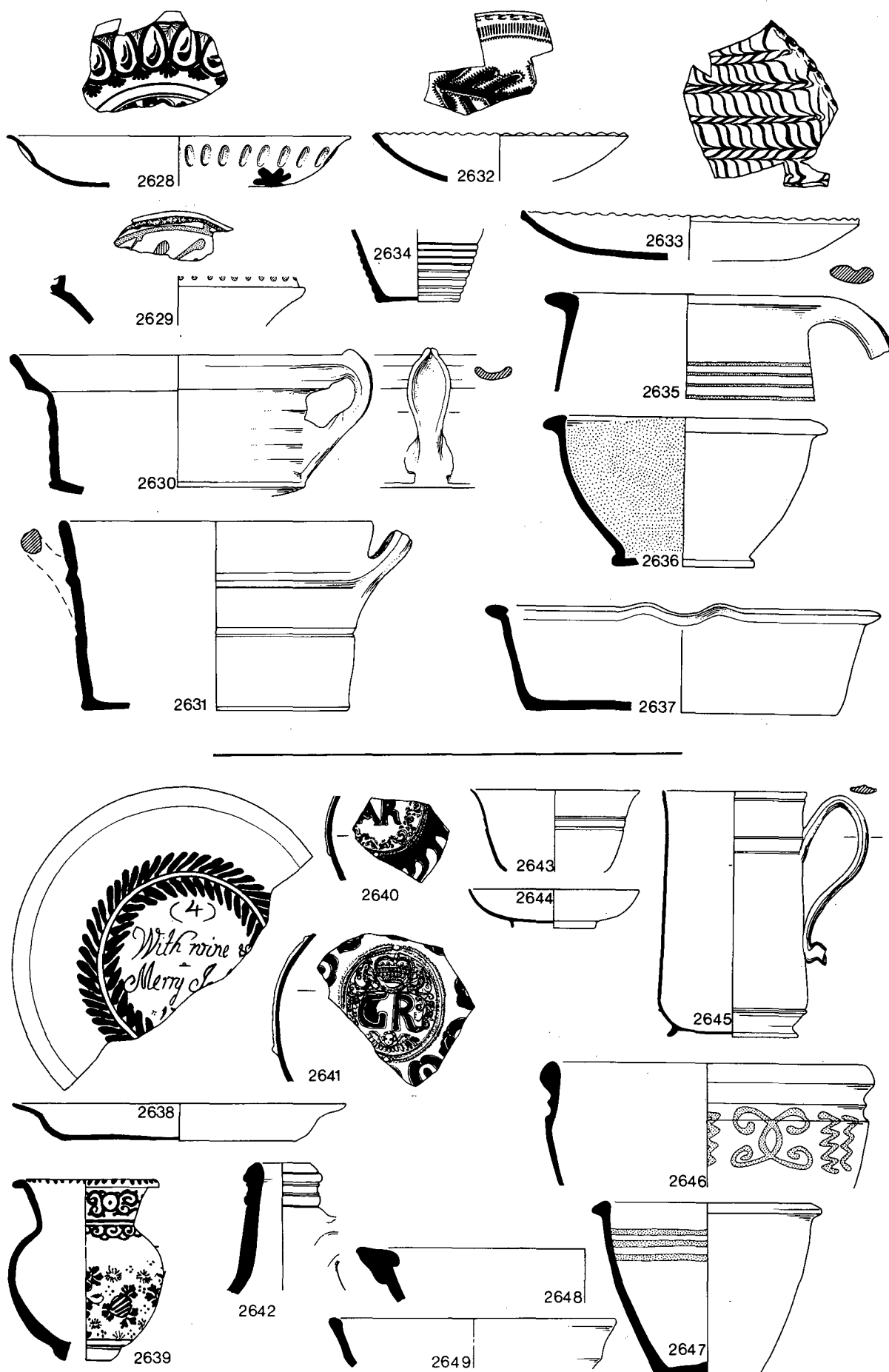

Fig. 119. High Street, Topsham 1977, c. 1700–30; Friars Gate 101, c. 1740–60 (scale 1:4).



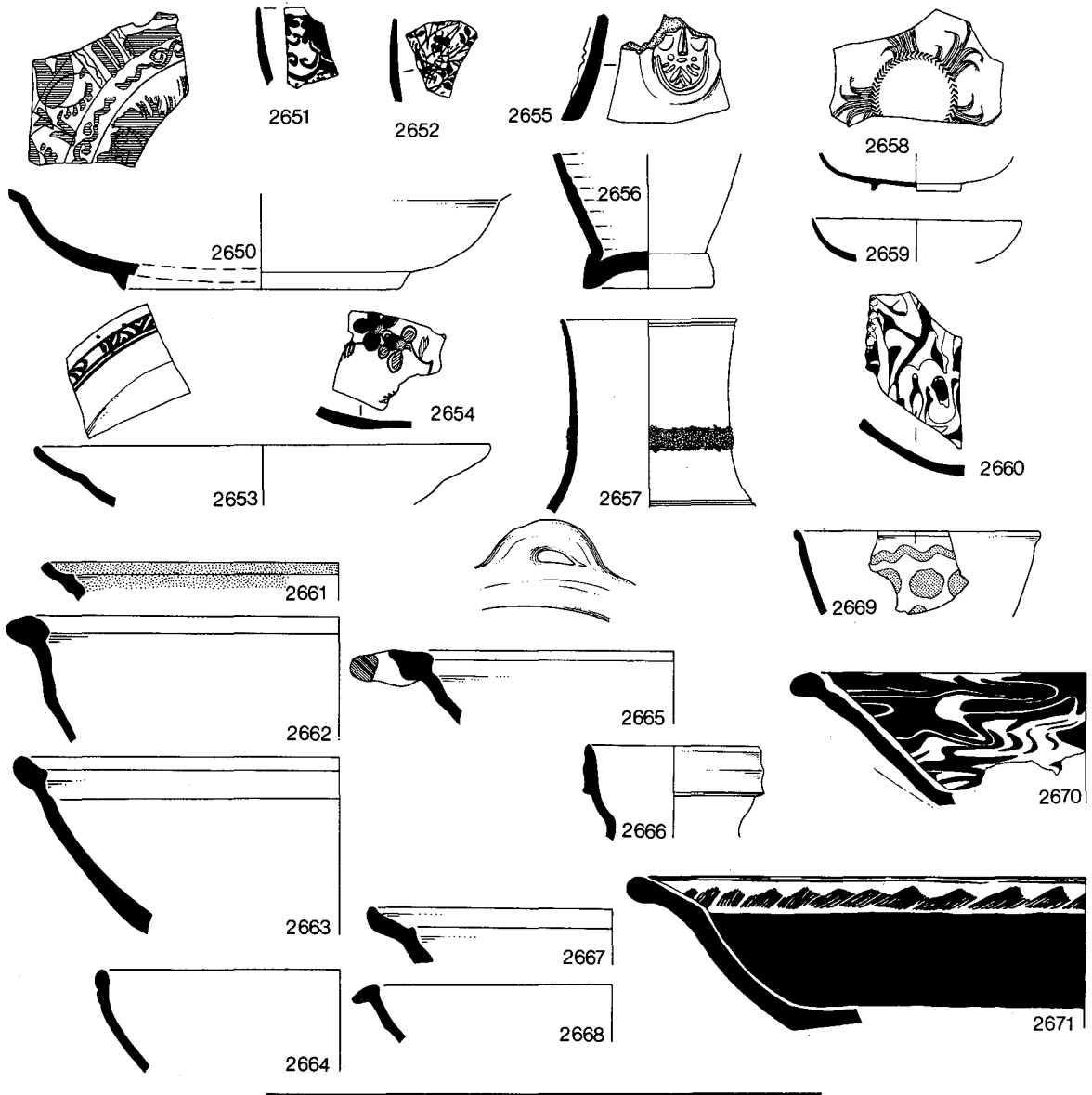

Fig. 120. Goldsmith Street 214, c. 1740-60 (scale 1:4).

**2699** White<sup>4</sup> Staffordshire salt-glazed stoneware.  
*Not ill:* Nottingham stoneware; plain delftware chamber pot very similar to **2690**; N. Devon gravel-temp type 3C; S. Somerset 18th-century types 3E(5), 6.  
*Date:* c. 1730-60.

**RACK STREET 1420 (Fig. 122)**

Pit group.

*Clay pipes:* Type L1, c. 1690-1720; spurred type, large, c. 1720-50.

*Imports and non-local English*

**2700-2** Chinese porcelain. **2700** plate painted in blue with a brown border, c. 1740-50; **2701** small cup with *int* border in red, c. 1730-50; **2702** saucer with foliated and moulded rim painted in light blue with enamels over, now decayed. In centre, framed panel with Chinese figures in enamel outlined in red with areas of black and red enamel. Rim painted with chrysanthemum in blue. Possibly *famille rose*, c. 1735-65.

**2703-4** Delftwares. **2703** plate painted mid blue, with white back, English, c. 1720-40; **2704** plain chamber pot, English, 18th-century.

**2705** Westerwald tankard or jug neck with incised floral motif in blue surround.

**2706-9** Staffordshire wares. **2706-8** plain white salt-glazed stonewares; **2709** teapot in fine pink fabric with pale orange *int* and *ext* glaze, and applied 'sprigged' floral

motif in white clay, with patches of green, blue and red-brown glaze. Identical vessel illustrated by Rackham (1935, Pl. 46F, No. 640, dated c. 1750).  
 Bristol-Staffordshire pressed plate.

**2710**

*Local wares*

**2711-24**

South Somerset 18th-century types. **2711-12** plates with marbled slips, glazed *int* white and brown, with spots of copper green; **2713-16** cup, plate, drug jar and cup with slip and copper mottling, glazed green; **2717** cup with *ext* slip band; **2718** jug top with trailed slip bearing date 1]76[ . . . , the figures positioned on each side of a pulled spout; **2719-20** plates with trailed slip, **2720** is the earliest stratified example known to the writer of the coarse slip-trailed dishes glazed yellow-and-brown, which are common at the end of the 18th century and in the 19th; **2721** small ?condiment dish, a wheel-thrown vessel squashed after throwing, with *int* and *ext* slip with copper mottling, glazed speckled green; **2722** bowl with pulled lip and trailed slip; **2723** tankard; **2724** ?teapot, an unusual form with trailed slip.

*Not ill:* S. Somerset types 1A(2) one sooted on rim, 1D, 2A (one sooted *ext*), 2C, 3D(3), 5, 6, 10, 11.

*Date:* The dated sherd **2718** of 1] 76 [ . . . provides a *terminus post quem* for the group. There are no creamware sherds, and it must belong shortly after 1760.

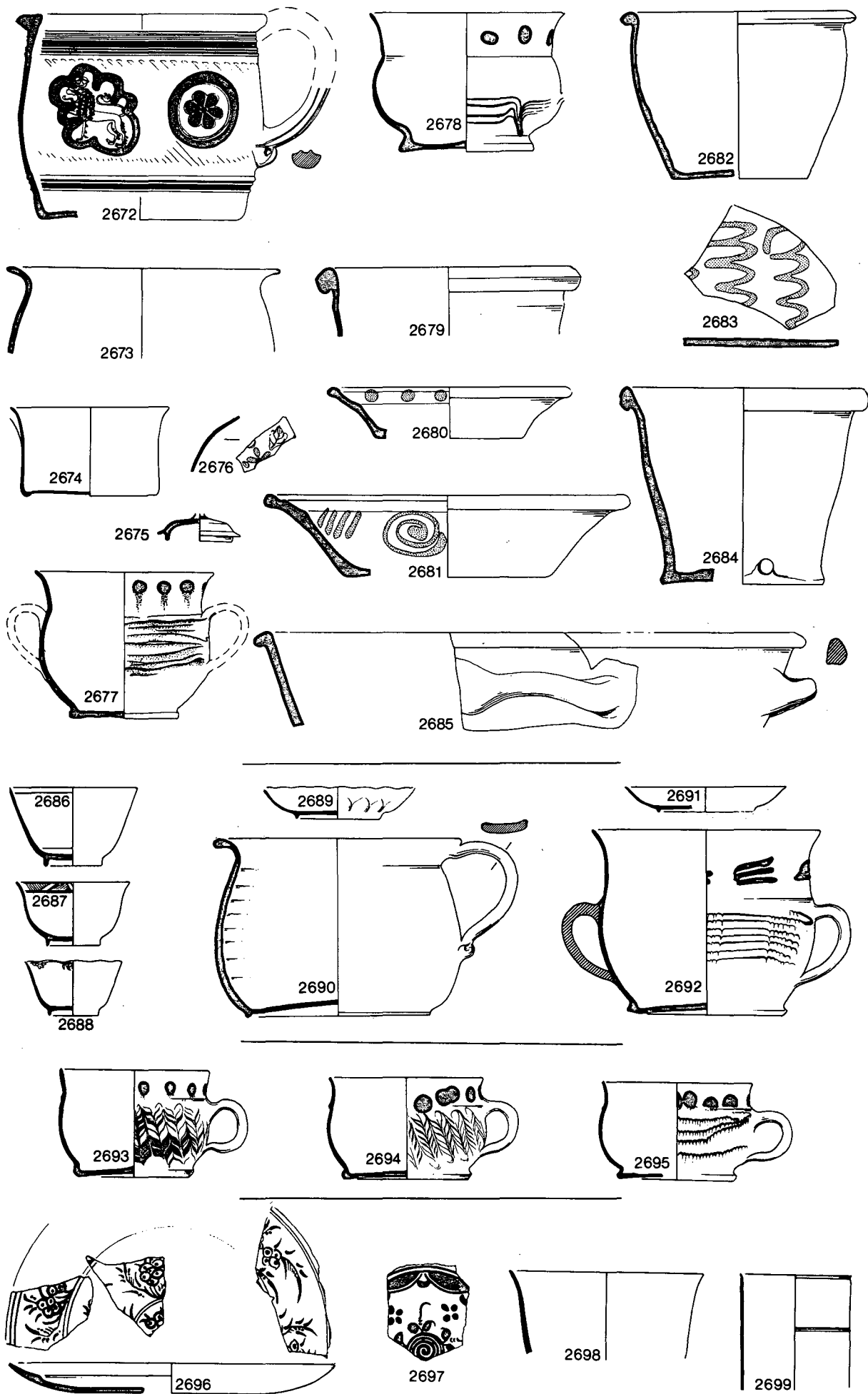

Fig. 121. Mid and late 18th-century groups from various sites (scale 1:4).

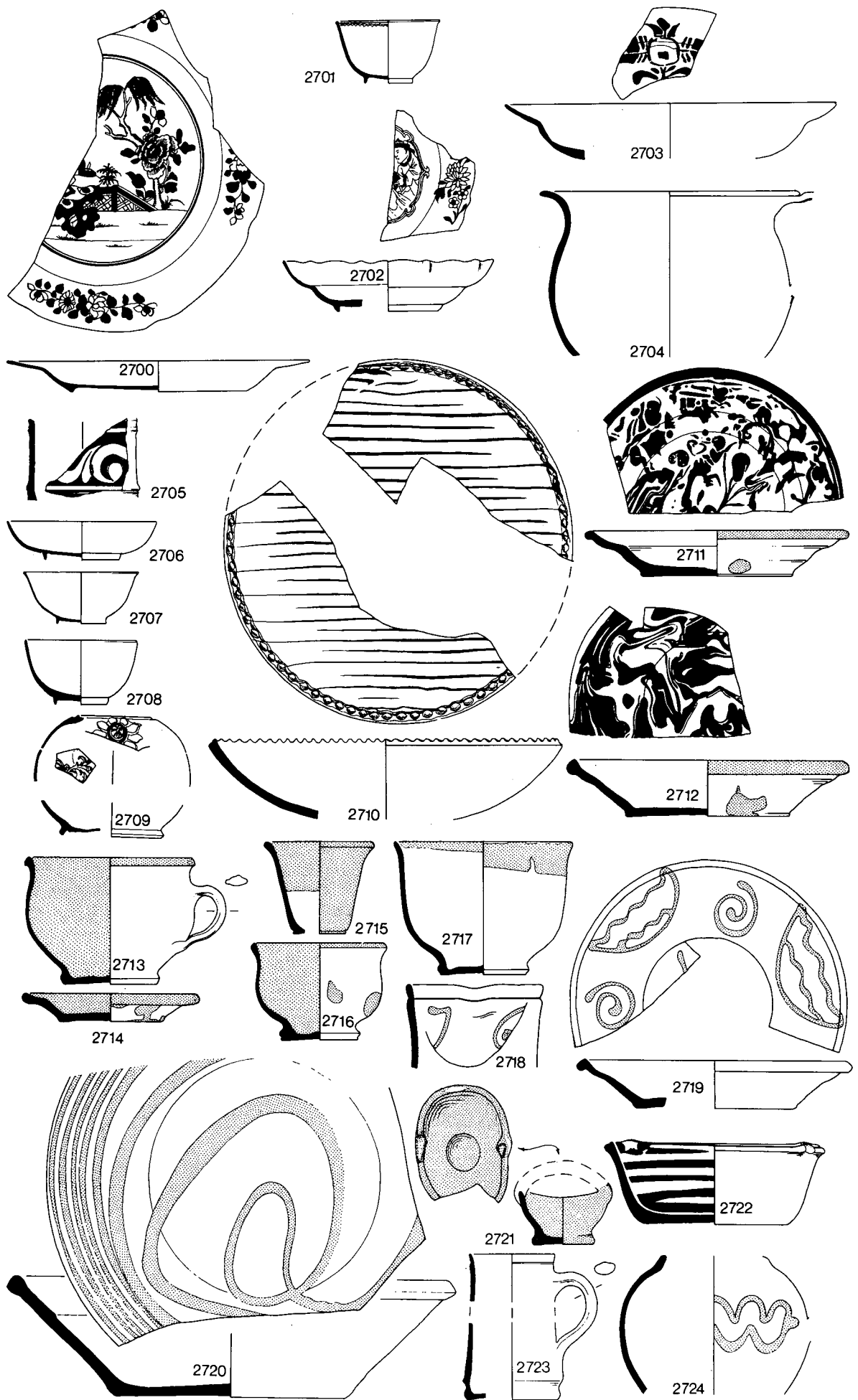

Fig. 122. Rack Street 1420, shortly after 1760 (scale 1:4).

## POST-MEDIEVAL WARES FROM OTHER CONTEXTS

Details of the associations, provenances, museum accession numbers and descriptions of these wares will be found in MFs 77–101.

*Italian wares* (Fig. 123)

- 2725** Florentine maiolica sherd. Hard fine pink-buff fabric, *int* tin glaze painted yellow and green, cross-hatched in black. 15th-century type, context of c. 1550–1600 (H. Blake ident.).
- 2726–9**, **2731** Montelupo tin-glazed wares. **2727** jug in context of c. 1598–1624.
- 2730** North Italian blue-on-blue maiolica.
- 2732** ?Italian tin-glazed sherd with hard red fabric, greenish-white *ext* painted mauve and green; lead-glazed *int*.
- 2733–4** North Italian marbled wares; **2733** red-and-white large lions'-head costrel; **2734** in context of 1642–59, four-colour marbled bowl.

*Iberian wares* (Fig. 123)

- 2735–8** Valencian lustrewares. **2735** dish with front showing leaves in blue, tendrils in lustre, decayed lustre on back; **2736** albarello with all-over blue painting; **2737** dish rim; **2738** in context of c. 1560–1624 with delicate lustre pattern (J. G. Hurst ident.).
- 2739** 'Isabela polychrome' ware, late 15th/early 16th-century (Goggin 1968, 126–8).
- 2740** Spanish tin-glazed dish in context of c. 1550–1600. Granular pink fabric.
- 2741** Sevillian plate in *cuerda seca* technique (Fotheringham 1936, 22; von Brigitte Klesse 1966, 106). Buff fabric, areas of brown, blue, mauve and green glaze. Context of c. 1500–50.
- 2742** 'Yayal' style dish. ?Sevillian (Goggin 1968, 128–30). Buff fabric, pale blue circles.
- 2743** Spanish lead-glazed dish. Coarse red fabric, thick green-brown glaze with black patches.
- 2744–5** Olive jars in context of c. 1690–1720.
- 2746–51** Merida-type wares. Dates of contexts: **2746** c. 1520–50; **2747** c. 1500–50; **2748–9** 1536–c. 1550; **2750** c. 1500–70. Nos. **2748–51** *thin-sectioned*, all fabric 2 (p. 145).
- 2752–3** Probable Portuguese tin-glazed sherds with intense blue painting.

*Low Countries and German wares* (Fig. 124)

- 2754–8** South Netherlands maiolica flower vases, jug and dishes. **2754** associated with Raeren; **2758** in group of c. 1550–1600; painting of **2757–8** shown at half-size.
- 2759** Cologne encrusted white ware ?goblet with rich mid green glaze over quartz, context of c. 1600–42 (J. G. Hurst ident.).
- 2760** Weser slipware. Context of c. 1600–42.
- 2761–3** North Holland slipwares. **2761** context of c. 1630–42.

*French wares* (Fig. 124)

- 2764–7** Beauvais sgraffito wares. **2764–5** albarelli, **2764** inscribed TOUT YRA BIEN, presumably a reference to the medicinal effect of the contents, **2765** single slip; **2766** dish; **2767** yellow-glazed drinking jug medallion.
- 2768–70** Beauvais stonewares.
- 2771–6** Saintonge wares. **2771–2** chafing dishes of types CV, CII (Hurst 1974b, 243–5); **2773** polychrome jug of type AII (*ibid.*, 226–9) in context of c. 1720–50; **2774** sherd with blotchy red slip; **2775** marbled ware in context of c. 1720–50; **2776** bowl rim, type B (*ibid.*, 230–1).
- 2777–8** Fine white wares with mid green glaze; **2778** a chafing dish, ?north French.

*Stonewares* (Fig. 125)

- 2779** Raeren copy of a Siegburg shape.
- 2780–1** Cologne-Frechen.
- 2782** Siegburg *schnelle* with Royal Arms of Spain, late 16th-century (See Pl. 3).
- 2783** Cologne-Frechen with acanthus leaf, roundel, mid-late 16th-century.
- 2784** Raeren panel jug, late 16th-century.
- 2785–96** Frechen Bellarmines, **2791** with cobalt blue patch.
- 2797–2811** Westerwald jugs, tankards, etc.

*Delftware*s (Figs. 126–7)

- 2812–22** Dutch types, early 17th-century with coarse pink-buff fabrics and lead-glazed backs.
- 2823** Drug jar in context of c. 1690–1720.
- 2824–34** Dutch types, late 17th/early 18th-century. Dates of contexts: **2826–8** c. 1690–1720; **2832** c. 1800–20; **2833** c. 1690–1720. Dates of production suggested by M. Archer: **2825** late 17th-century; **2826** c. 1700; **2827** c. 1700–20; **2828** c. 1700 (with 'sealing wax red' painting); **2829** c. 1720–30; **2830** late 17th-century ('pancake plate'); **2831** c. 1680 (outlined in black); **2832** c. 1688–1710; **2833** mid or late 17th-century; **2834** c. 1680–90 (polygonal moulded cup).
- 2835–48** English types, late 17th/early 18th-century. Dates of contexts: **2836** c. 1720–50; **2838** c. 1740–60; **2845** c. 1690–1720; **2846** c. 1720–50; **2848** c. 1740–60; Attributions: **2835** 'chinamen among grasses', London, c. 1680–90; **2837** London or Bristol, c. 1730–40; **2838** London, c. 1740–50; **2839–40** *bleu de Nevers*, ?London, c. 1680–90; **2841** English, c. 1730–40; **2842** English, c. 1700–50; **2843** English, c. 1700–25; **2844** English, c. 1740–60; **2845** ?London, late 17th-century; **2846–7** London or Bristol, c. 1700 and c. 1700–25; **2848** ?English.
- 2848–52** Miscellaneous. **2848** painted intense dark blue. Dutch or German; **2849** continental, date uncertain; **2850** in context of c. 1770–1820, French, early 19th-century; **2851** mid 17th-century ?Portuguese; **2852** with 'de Grafse' on pale greenish tin glaze, ?Dutch, 19th-century.

*North Devon wares* (Fig. 128)

- 2853–9** Sgraffito-decorated wares, mid or late 17th-century.
- 2860** Trailed slipware.
- 2861–4** Plain yellow-glazed slipwares.
- 2865–71** Gravel-tempered wares including the only relief-decorated tile from Exeter (Keen 1969). Dates of contexts: **2865**, **2867**, **2869** all c. 1690–1720.

*South Somerset wares* (Figs. 129–30)

- 2872–8** Late 15th/16th-century types.
- 2879–93** 17th/18th-century types. Dated context: **2889** c. 1690–1720. **2879** condiment dish; **2883**, **2887–8** black-glazed.

*Miscellaneous* (Figs. 130–1)

- 2894–2901** English redwares. **2895** probably South Somerset; **2896** copy of CIII chafing dishes with their flat tops (Hurst 1974b, 243); **2898** flat iron, cf. those from North Devon and Wrangway kiln, Somerset; **2899** watering can, ?Goldsmith Street ware; **2900** knife-trimmed water-pipe; **2901** syrup jar used in sugar-refining with *ext* slip and traces of green paint (? from use as a shop sign).
- 2902** Italian oil jar (Ashdown 1972).
- 2903** ?Low Countries redware with sgraffito decoration.
- 2904** Plain redware, possibly a grenade like those published by Jewitt (1878, 106, Figs. 334–5).
- 2905–8** Bristol-Staffordshire wares. Dates of contexts: **2905–7** c. 1690–1720. **2905** red ware with *int* and *ext* black glaze; **2906** yellow slipware; **2907–8** reversed yellow slipware.

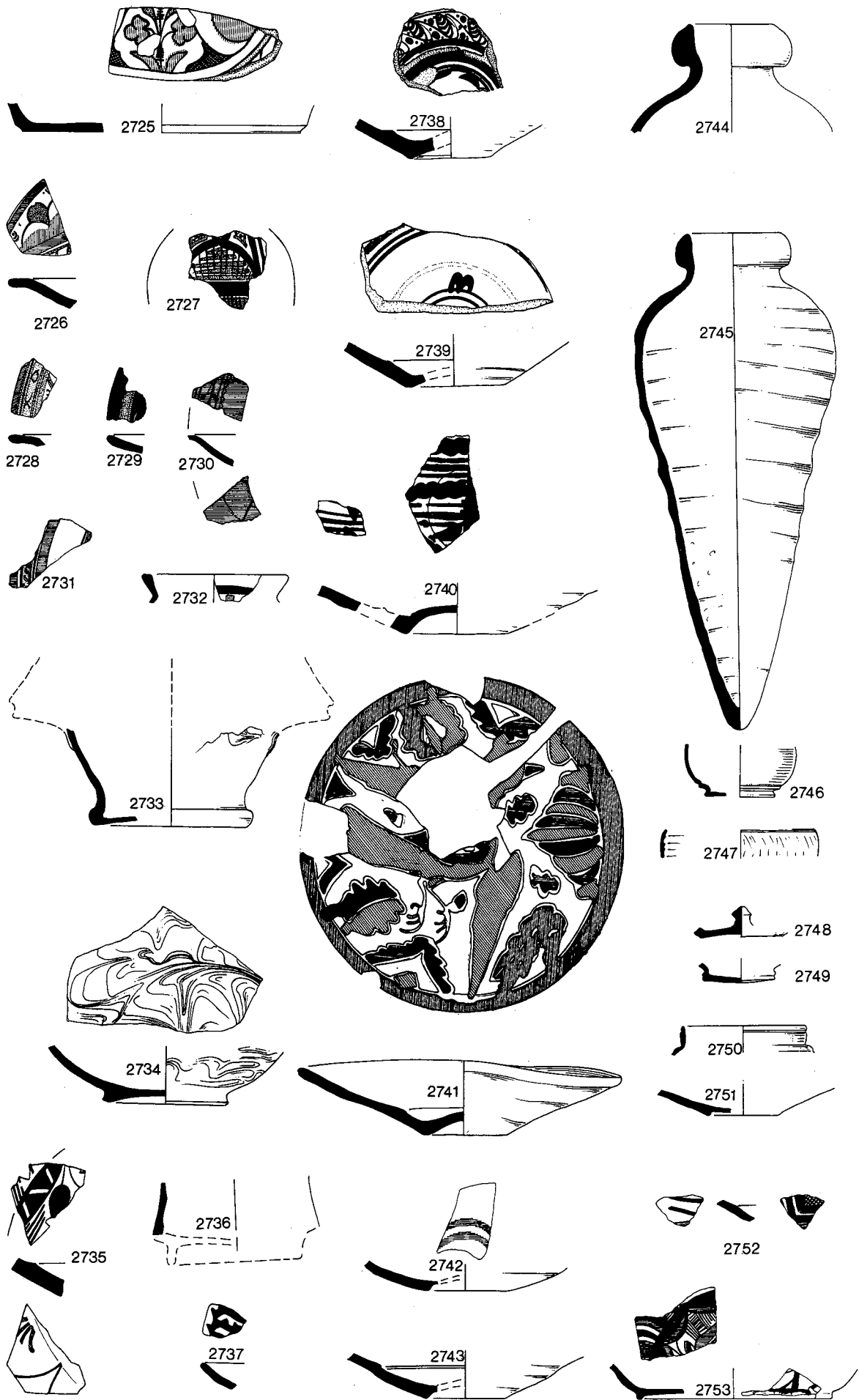

Fig. 123. Italian and Iberian wares from other contexts (scale 1:4).

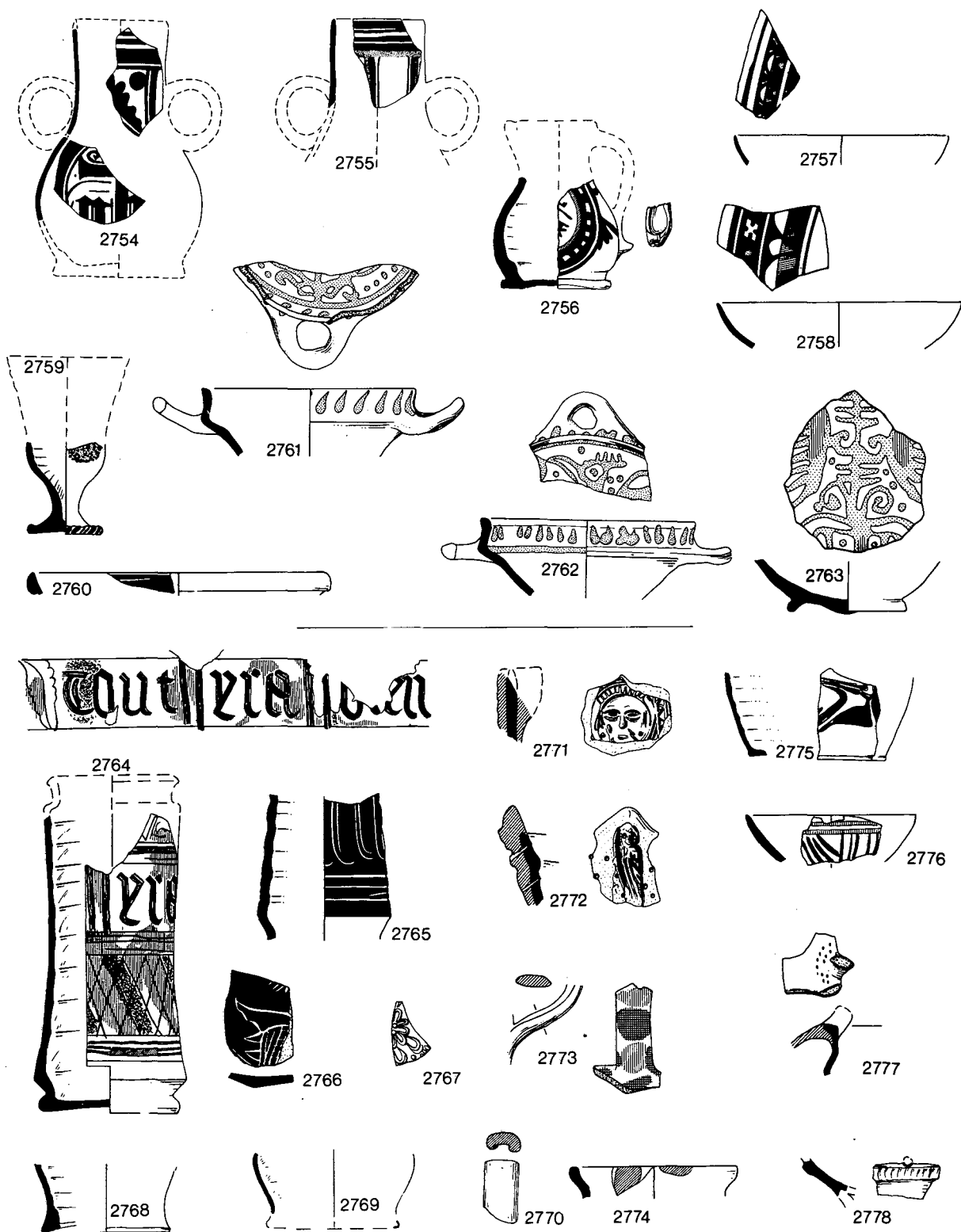

Fig. 124. Low Countries, German and French wares from other contexts (scale 1:4, except decoration 2757-8 1:2).

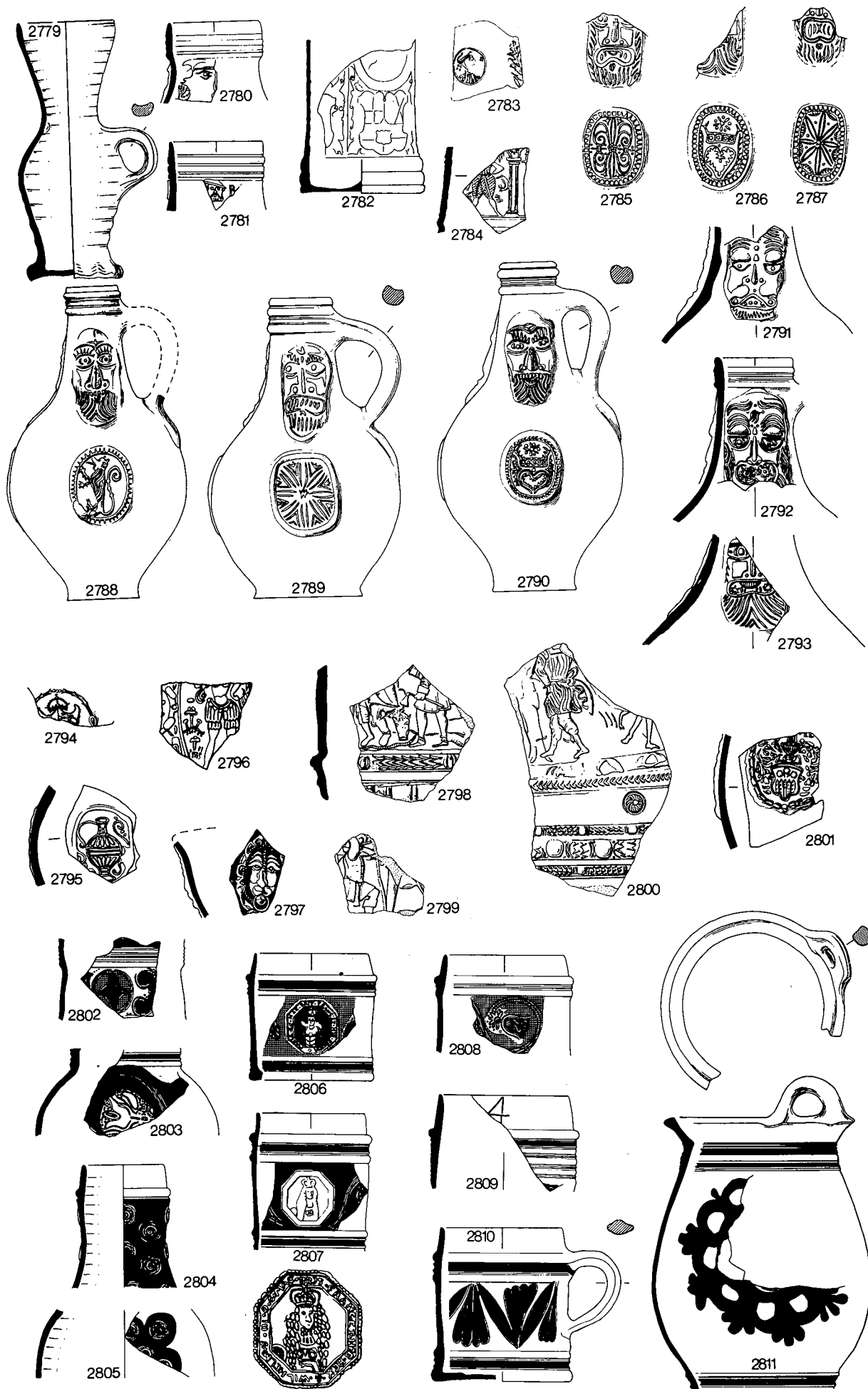

Fig. 125. Stonewares from other contexts (scale 1:4, except 2798–2800 and detail of 2807 1:2).



Fig. 126. Delftware from other contexts (scale 1:4).



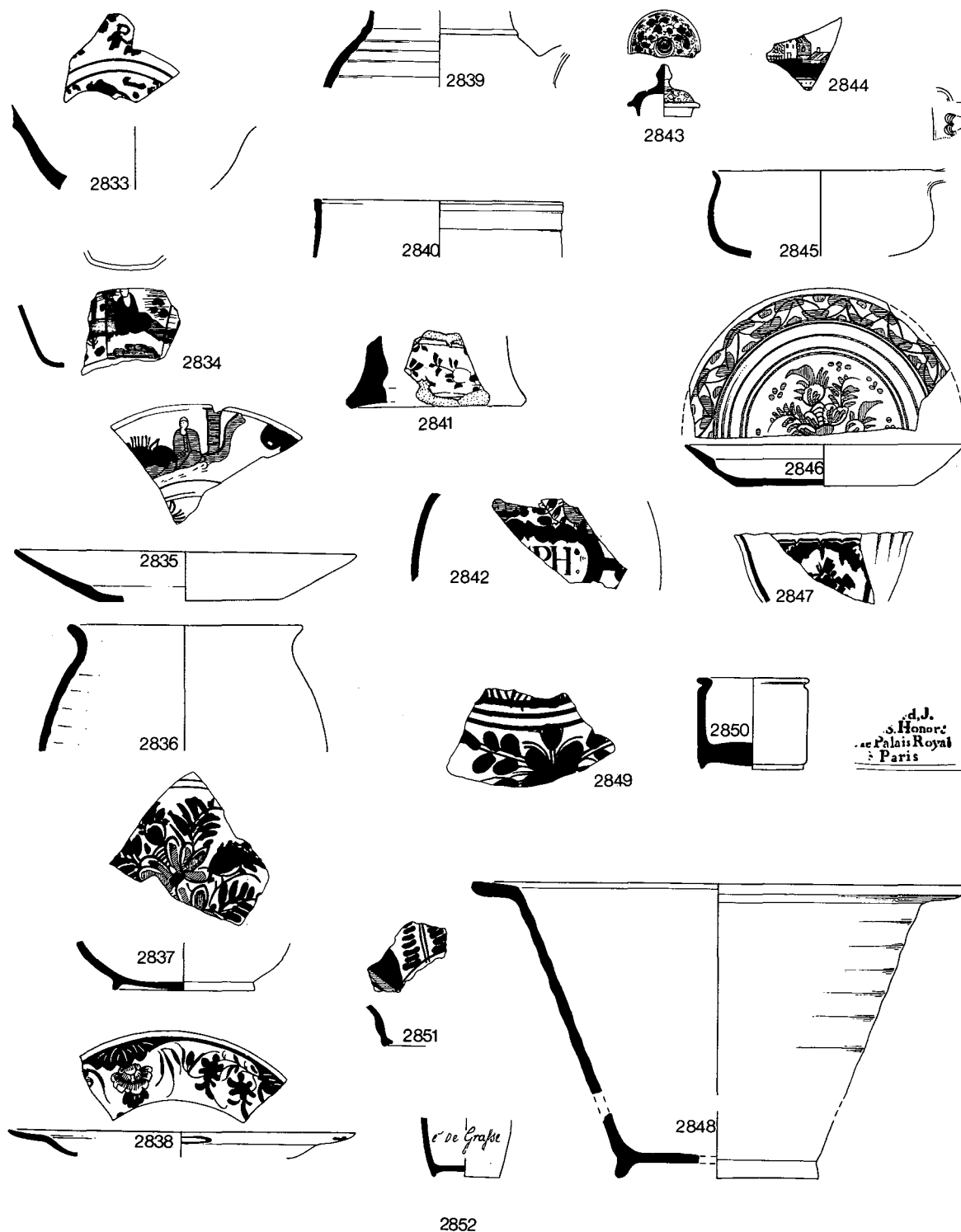

Fig. 127. Delftware from other contexts (scale 1:4).

2909–10 Tudor green wares.

2911–12 Surrey-Hampshire yellow-glazed white wares.

2913 Rim and decorated attachment in a fine white fabric with impressed stamp and incised lines; mid green glaze. K.J. Barton has suggested that this may be an 18th-century Saintonge vessel.

2914 Lobed cup, ?South Somerset.

*Chinese porcelain* (Attributions by J. Ayers) (Fig. 131)

2915 Small 'character cup' painted mid blue with pale blue horizontal lines on *int*.

2916–18 'Chinese Imari' jar lid, plate sherd and bowl sherd painted *ext* in dark blue, with red flowers and traces of gold; c. 1710–30.

2919 'Famille rose' cup with fluted walls, pink and red

border on rim *int*, and *ext* floral pattern with pink and red flowers and green leaves; c. 1750–65.

2920 'Steatitic porcelain' cup. Rather soft opaque white paste; reserves in relief, painted dense blue; figures in green, pink and red with traces of gold; brown rim; c. 1765.

2921 Fluted cup painted in underglaze blue with landscape scenes; c. 1745–65.

2922–9 Blue-and-white wares of c. 1725–60. 2922–3 small cups painted dark blue; 2924–6 dishes with plain *ext*, 2926 with brown rim; 2927 small cup with blue cross-hatching on rim *int*; 2928 plate with brown rim and plain *ext*; 2929 fine tall cup with landscape scenes, c. 1725–40.

2930 Plain spoon with sanded base.

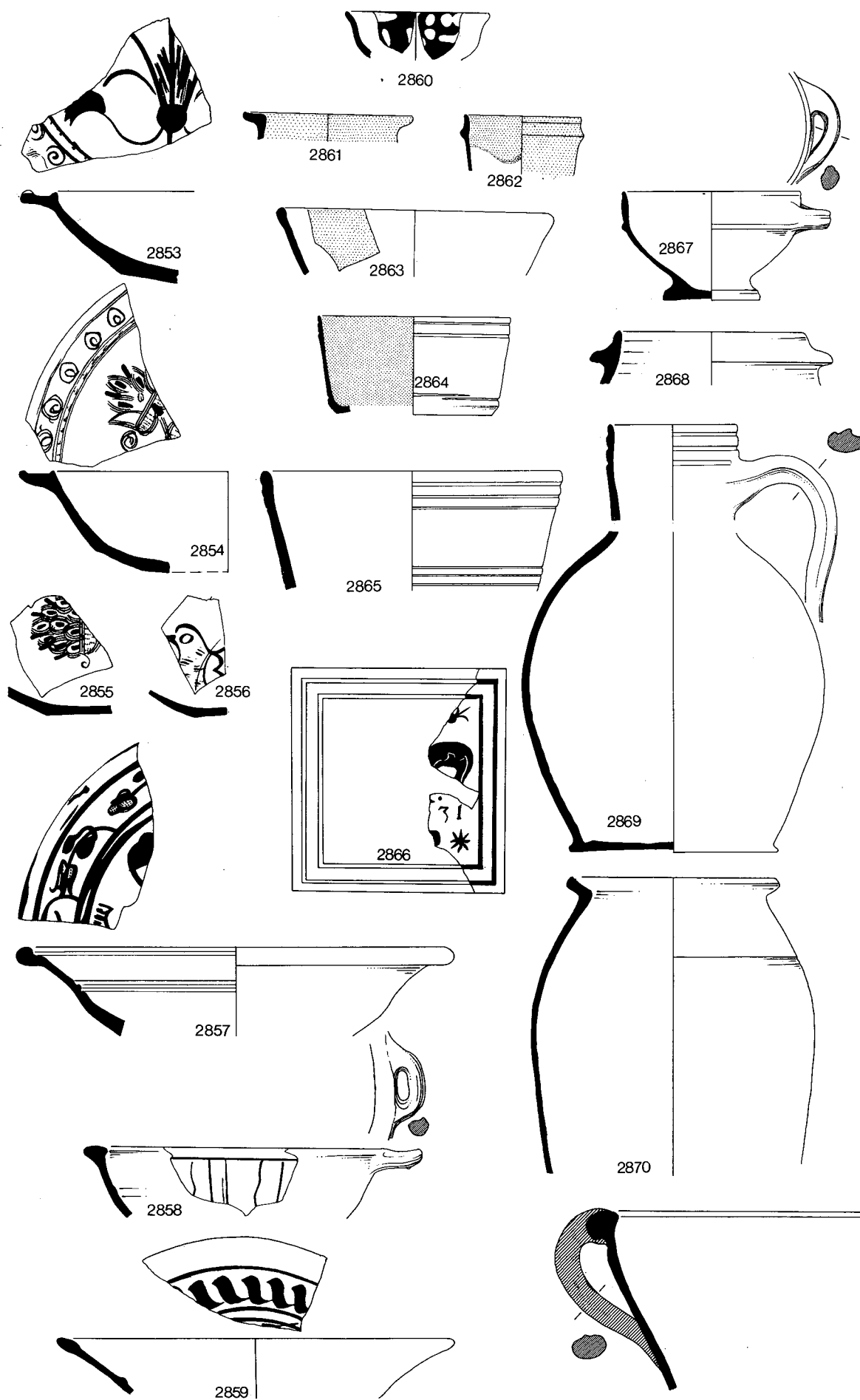

Fig. 128. North Devon wares from other contexts (scale 1:4).

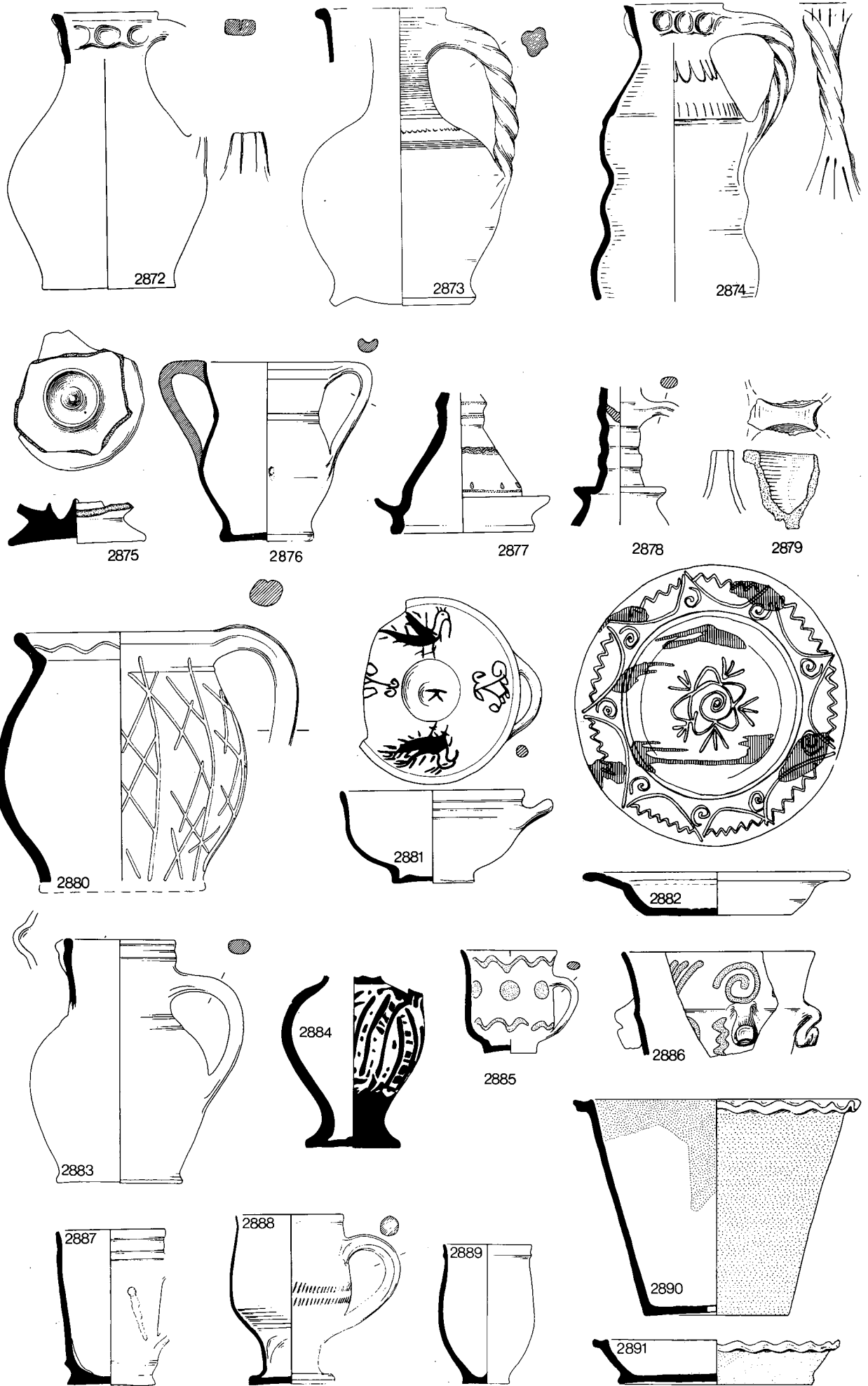

Fig. 129. South Somerset wares from other contexts (scale 1:4).



Fig. 130. Miscellaneous wares from other contexts (scale 1:4).

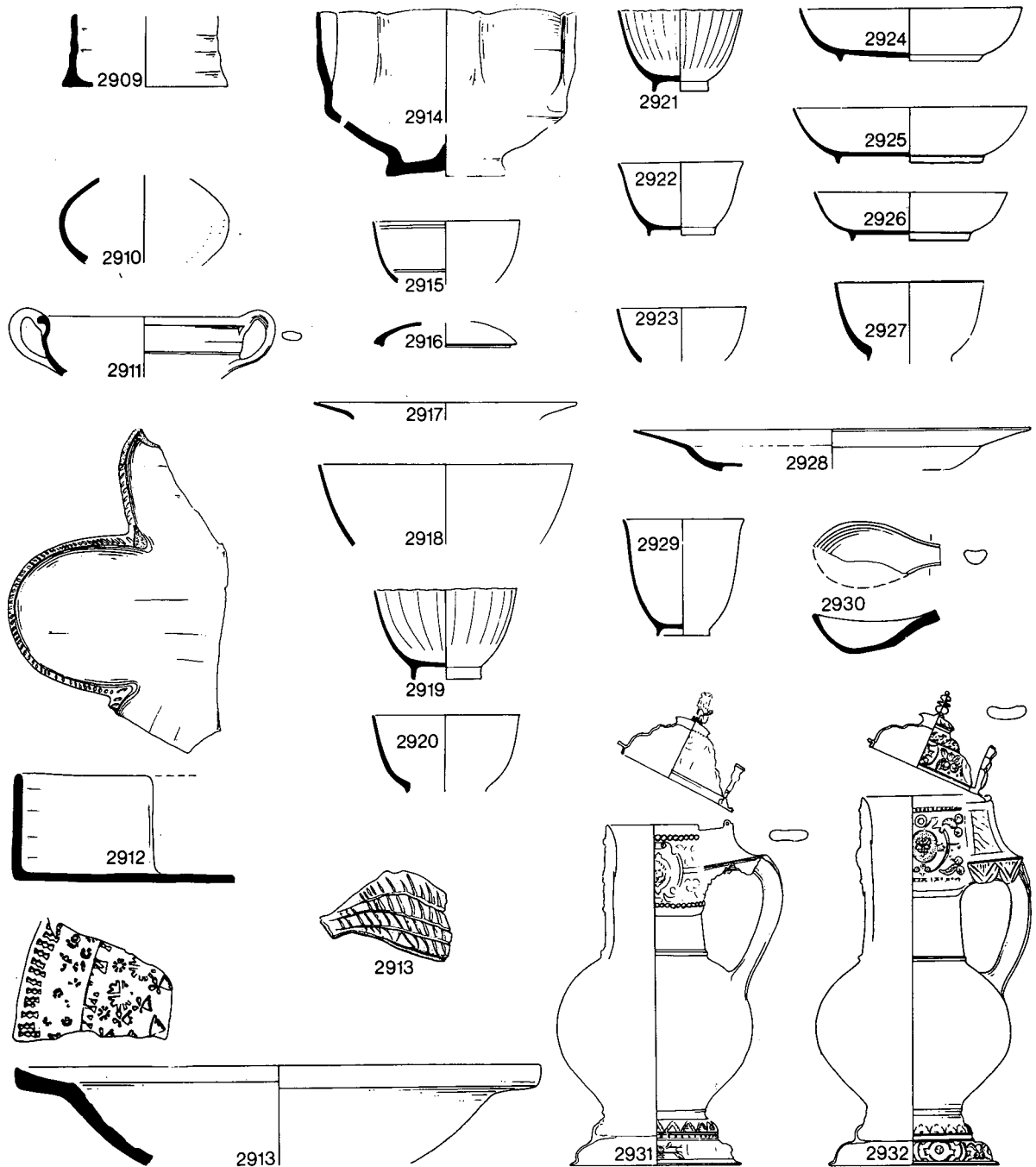

Fig. 131. Miscellaneous wares and Chinese porcelain from other contexts; Frechen stonewares mounted in Exeter silver (scale 1:4).

*Addendum: two Frechen jugs mounted in Exeter silver*

- 2931** Exeter Museum Acc. No. 107.1962. Frechen stoneware jug with silver-gilt mounts. Marked EASTON (incuse) with date-letter for 1578-9 in shield and Exeter assay mark. Scratched 'viii oz' on underside of foot, probably for assessment in probate.
- 2932** Exeter Museum Loan No. 125-1. Frechen stoneware jug with silver-gilt mounts. Marked YEDS, i.e. [John] Edes (incuse) with crowned Exeter assay mark. Scratched 'viii oz, iiis vd' on underside of foot, probably for assessment in probate.